

Meeting 1: Human Factors Issues in Aircraft Maintenance and Inspection

Proceedings of the First Meeting on Human Factors Issues in Aircraft Maintenance and Inspection

William T. Shepherd, Ph.D., Editor

James F. Parker, Jr., Ph.D., Co-Editor

October 1989

FOREWORD

The Federal Aviation Administration (FAA) is mandated to ensure the highest level of safety in American aviation. A matter of concern recently has been the increasing age of jet aircraft in the air carrier fleet. Many of these aircraft now are entering their second and third decade of use.

In June of this year, the FAA sponsored a meeting of representatives of the aviation industry to review problems associated with aging aircraft. While much of this meeting addressed issues of hardware, metal fatigue, and corrosion, there was a discussion of human factors in maintenance. Today's meeting reflects a growing interest in human factors and its potential contribution to continuing aviation safety.

I hope that the perspective of today's meeting will extend beyond just the aging aircraft problem. We should consider new technologies such as use of composite materials, for example. The effect of automation, advanced electronics, new aircraft design techniques, and training innovations also should be reviewed. Any issue that bears on the performance of maintenance personnel should be included.

All segments of the aviation industry concerned with maintenance are in attendance today. We have representatives from the Federal Aviation Administration, The National Transportation Safety Board, aircraft manufacturers, airline operators, regional airlines, helicopter operators, the maintenance training establishment, those concerned with new technologies, and, in particular, several human factors scientists with impressive research credentials relating to inspection and maintenance. With the skill and expertise represented here, I am certain we will develop positive recommendations of real value to the FAA and to aviation as we consider ways to ensure optimum use and support of maintenance personnel.

William T. Shepherd, Ph.D.

EXECUTIVE SUMMARY

The Federal Aviation Administration sponsored a two-day meeting in October 1988 to address issues of human factors and personnel performance in aviation maintenance and inspection. Presentations were given by some 13 individuals representing the full spectrum of interests in commercial aviation. Presentations also were given by three human factors scientists with backgrounds in vigilance and industrial inspection technology. Each presentation, as well as the following question and answer period, was recorded for transcription and study.

The objective of the meeting was to identify human factors issues of importance, particularly as such issues might contribute to inspection or maintenance error. The desired outcome was to be (1) an improved understanding of personnel performance in aviation maintenance and (2) recommendations, as appropriate, to the FAA concerning needed research efforts and/or possible new or revised regulatory actions.

Recommendations presented to the Federal Aviation Administration are summarized as:

1. More recommendations centered on communication than for any other topic discussed. Apparently the changing structure of the airline industry has disrupted communication networks with existed in earlier years. These networks were quite useful in disseminating maintenance information. Accordingly, it is recommended that the FAA foster at least one additional meeting of this kind to review specific topics noted in subsequent recommendations.
2. The FAA should consider means for encouraging or developing a data base of industry information concerning maintenance technologies, procedures, and problems. Many individual data bases exist. These should be consolidated and expanded.
3. The current review of Part 147 should be expedited as feasible. Results should include provision for specialization training as an advanced part of the curriculum of approved schools. Licensing procedures for avionics technicians also should be reviewed.
4. The supply of trained maintenance personnel is inadequate. The FAA should encourage or develop promotional materials regarding maintenance as a career.
5. "Advances in Training Technology" should be addressed extensively in any future FAA-sponsored meeting.
6. The pressure of "gate time" is an ongoing problem. All parties should consider ways to insulate inspectors from production and from the rest of maintenance.
7. Consideration should be given by the FAA to the conduct of a task analysis, or some modified version, of both mechanic performance and inspector performance. This provides critical information for any job redesign and improvement.
8. A research center, or program, where maintenance concepts could be studied in detail would be of great value. This could exist either at the FAA Technical Center or the Civil Aeromedical Institute.

9. Effective maintenance requires appropriate maintenance information. The FAA should review the preparation and delivery of maintenance manuals to ensure that the latest and most appropriate maintenance data are available to maintenance personnel as rapidly as possible. Particular attention should be given to information concerning wear limits, damage limits, repair schemes, and aircraft wiring diagrams.
10. A number of organizations are conducting research activities relating to maintenance performance. Channels should be established so that details of these activities can routinely feed into the data base noted in Recommendation Number 2. In addition, any future meeting should include a full session devoted to "Requirements and Improvements in the Preparation and Delivery of Maintenance Information."

MEETING WELCOME

*Anthony J. Broderick
Associate Administrator for Regulation and Certification
Federal Aviation Administration*

There is considerable interest today at the FAA in the subject of aircraft maintenance and inspection. I personally am very excited about the fact that people are willing to spend their valuable time to get together and talk about something which, it is fair to say, we know little about. We in the FAA are not sure where this interest and this take us somewhere that we would rather be compared to where we are today. Because of the lack of maturity of the subject matter, as some might say, we are in a position where we might be able to make significant contributions to aircraft maintenance and aviation safety with a fairly modest investment of time and resources. It will be exciting to be a part of this activity.

I am impressed with the cross section of professional brought together to address today's topic - people from academia, the airlines, the manufacturers, the FAA, and a number of other fields with activities relating to aircraft maintenance. Only a collective effort and cooperation of this type, in a nice quiet room, will result in the progress we need.

What we are really talking about today is human performance in aircraft maintenance, including everything from training of maintenance personnel to development of procedures for maintenance of complex digital flight equipment. We are particularly concerned with the human's role in the inspection of older aircraft which have been in the fleet for twenty or more years. We begin, of course, with the full realization that a large measure of professionalism exists in the maintenance business today. The problem is complex and will not be solved simply by urging the industry to bring more professional aboard or recommending a nice warm room in which to perform maintenance.

The problem, as I see it, is that we do not have an organized body of information that we can apply when an engineer determines that an inspection is needed for cracks in a particular section of an airplane. How do you do that inspection? What should the engineer know about principles of human performance that will ensure that the inspection is performed with best accuracy?

The FAA at this time is preparing an Airworthiness Directive for release which will require

additional inspections for certain older aircraft. For illustrative purposes, and these may not be quite the correct numbers, these inspections use a 40,000 landing cycle threshold to begin inspections, followed by a 4,000 landing cycle for repeat inspections. In this case, we are applying the same inspection criteria to an aircraft with 70,000 cycles as we are to one with 30,000 cycle. This bothers me because the process for deriving the threshold to inspection and repetition assumes that the development of cracks may be detectable at 40,000 cycles and that, if cracks are not found, the aircraft may be flown safely for another 4,000 cycles before new cracks can develop to a hazardous extent. When this process is applied to an aircraft with 60,000 or 70,000 cycles, we are saying that if the aircraft is inspected in the next 500 cycles and then 4,000 cycles later, it will be safe. We now have evidence from two recent instances, well known to most of you, in which we found that this may not be true.

In the well-publicized Aloha Airlines incident, the airplane was inspected and an airworthiness action performed just a few months before it had the tragic inflight episode. Then, just recently we found another airplane, with another airline, which had about 50,000 to 55,000 cycles and had developed a major crack and a number of smaller ones. This airplane also had been inspected earlier, with its cracks discovered only as it was going in for repainting. So here we have two airplanes, with all the attention focused recently on 737's, for which somehow the system did not work. We have professional involved in engineering and professionals involved in maintenance and yet cracks developed undetected.

We must develop an improved approach to the inspection process and, more important, it must be an organized approach. We need to take a technological approach, break the process into its components, and then examine each component to see if we can build a body of knowledge that will apply.

Is vigilance the issue? The job of performing these inspections can be terribly boring and the job frequently must be performed under adverse conditions. Is vigilance simply the answer? Or are we expecting too much of people at any level of vigilance?

What about training? Aircraft of today are more complex and employ a variety of material and construction techniques. New systems are available for the inspector. Has our training establishment kept pace with these changing technologies. While I suspect that it has at least to certain extent, I do not know whether additional attention is required on training.

Another issue is communications. How do engineers at a manufacturing facility, where a Service Bulletin is written, and FAA engineers, who approve that Bulletin, communicate with engineers at an airline and with airline maintenance personnel? How do we communicate what we expect and suspect we do a heart-felt job but I do not believe we have good guidelines to follow. This is a part of the system that has never been critically analyzed.

Then there is the work environment. Chicago in the winter can be a cold place to be. Tasks that normally are routine and that must be performed hundreds of times can be quite difficult under these conditions. When you look toward some of the more subtle inspections we are talking about, there is a question as to whether we are realistic in expecting quality performance under adverse working conditions.

So, how have we gotten away with it? Well, I am not sure we have gotten away with it. We

have seen some significant maintenance-related accidents in the last decade. Also, the average age of the fleet is increasing. As a result, greater demands and greater reliance are going to be placed on the maintenance and inspection functions. We must know the good and bad points of these functions and how to deal with them.

One avenue for consideration, and a favorite topic of mine, is the use of robots. When I visit Boeing, I see huge wings being automatically drilled and riveted. Excellent use is being made of robotics technology. But when I go to an airplane on the line or in a maintenance operation for heavy checks, I do not see a lot of automation being applied. Why not? Possibly because it is expensive and not readily available. But shouldn't this be something we look to as a basis for improvement? Shouldn't we encourage industry to develop effective ways to use robotics? While this might not provide an ultimate answer, it could contribute significantly.

In the future, we will be relying not so much on the genius of the designer and the production staff but, with the aging fleets, on the genius and the dependability of the maintenance staff. In other FAA programs related to the aging aircraft fleet, we are looking at the structural aspects of aircraft design, our database requirements, and actions to be taken. But no matter what we do with regard to design improvements or production improvements, we must recognize that we will rely more and more heavily on maintenance in the coming years.

Let me close by again thanking you for coming. We are here to exchange information and listen to ideas. Even if, as a result of all the thinking and talking we do here, not a single FAA Directive is written, I am confident that the exchange of information among leaders in this part of the aviation industry will be worthwhile and, in itself, will result in safety improvements. Thank you.

INTRODUCTION

The Federal Aviation Administration sponsored a two-day meeting in October 1988 to address issues of human factors and personnel performance in aviation maintenance and inspection. Presentations were given by some 13 individuals representing the full spectrum of interests in commercial aviation. Presentations also were given by three human factors technology. Each presentation, as well as the following question-and-answer period, was recorded for transcription and study.

The objective of the meeting was to identify human factors issues of importance, particularly as such issues might contribute to inspection or maintenance error. The desired outcome was to be (1) an improved understanding of personnel performance in aviation maintenance and (2) recommendation, as appropriate, to the FAA concerning needed research efforts and/or possible new or revised regulatory actions.

The following section presents recommendations developed through a synthesis of comments and suggestions made by attendees both in their formal presentations and during subsequent discussions. The recommendations have been reviewed for intent and for accuracy by each of the presenters. Following the recommendation, an edited version of each presentation is included as Appendix A.

AVIATION MAINTENANCE PARAMETERS

Aviation maintenance operates as an indispensable element in support of the larger U.S. aviation industry. A review of human factors issues affecting the quality and efficiency of aviation maintenance personnel should be conducted with an understanding of industry parameters. An overview of the industry will illustrate the scope and diversity of maintenance requirements faced by the industry.

The mix of aircraft in the air carrier and general aviation fleets is shown in **Table 1**. The data for air carriers in Table 1 include scheduled, supplemental, commuter, air taxi, and air cargo carriers. These data illustrate the primary attention is being given to air carrier operations today. The carrier fleet constitutes almost exactly two percent of the entire number of aircraft operating within the United States. However, this fleet carries four times the passenger load of other classes of aircraft. In terms of safety of the general public, air carrier operations warrant the first look. However, no one should be insensitive to the fact that over 100 million passengers also are carried annually in general aviation operations.

TABLE 1
U.S. AIRCRAFT FLEET
(1986)

<u>Aircraft</u>	<u>Air Carrier</u>	<u>General Aviation</u>
Turbine	4,063	10,500
Piston	364	195,700
Rotorcraft	4	6,900
<u>Passengers Carried</u>	419 million	119 million

Air Transport Association (ATA)

Table 2 shows the projected growth of the U.S. aircraft fleet over the next ten years. This shows that growth as foreseen will take place in air carrier operations and in commuter airlines. No growth is projected for general aviation over this ten year period. New general aviation aircraft will enter the fleet but certainly not at the rate seen in 1978, the peak production year. Other aircraft will retire during this period, and as a result there will be no growth for general aviation.

TABLE 2
PROJECTED GROWTH OF
U.S. AIRCRAFT FLEET
(1987 - 1999)

<u>Fleet</u>	<u>Forecast Annual Growth</u>
Air Carrier	2.6%
Commuter	2.9
General Aviation	0.0
Domestic Passenger Load	4.6

Note: In past two years, 759 large jet aircraft were delivered.
Very few older aircraft were retired.

Federal Aviation Administration (FAA) (1988)

Table 2 also shows that during the past two years, 759 large jet aircraft have been delivered to the airlines. Over that same time period, very few older aircraft - the DC-9s and early 727s - have been retired. This illustrates the changing dynamics in fleet characteristics.

An important characteristic of both the air carrier fleet and the general aviation fleet is that each is growing older. **Table 3** shows the average age for a group of selected aircraft currently in use in the U.S. air carrier fleet. While these aircraft obviously were selected to demonstrate the aging characteristic, nonetheless they are representative of aircraft used in current operations. Note that four of these aircraft have an average age in excess of 20 years. Also, considering that these data are current as of the end of 1987, the average age of the aircraft shown is now somewhat greater than indicated.

TABLE 3
AGE OF SELECTED AIRCRAFT
IN U.S. AIR CARRIER FLEET

<u>Aircraft</u>	<u>Number</u>	<u>Average Age</u>
DC-8-50	16	23.1
727-100	344	21.7
BAC-1-11	38	21.6
DC-9-10	91	21.0
707	35	19.8
737-100	20	19.2
DC-8-70	85	19.2
747	167	13.9

Average age of all aircraft in U.S. air carrier fleet = 12.1 years. Data as of year-end 1987.

ATA(1988)

The age of the U.S. general aviation fleet is depicted in **Figure 1**. It is obvious that general aviation has the same problem with aging aircraft as the air carriers. Considering that these data now are probably two-years old and thus are shifted to the right slightly, the average age for the entire general aviation fleet is in the order of 20 years, with some aircraft more than 35 years old. It is also interesting to note that every year the data in Figure 1. are being pushed to the right slightly because of the fact that aircraft are not being retired from the general aviation fleet as had been initially anticipated and very few new aircraft are being introduced.

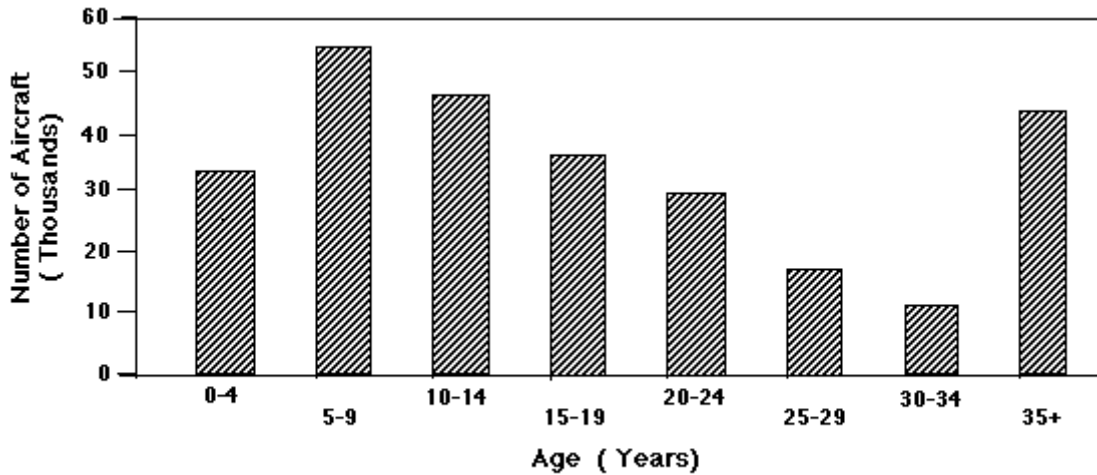

Figure 1 Age of U.S general aviation aircraft. (FAA, 1987)

While the age of an airplane is important, maintenance requirements for air carrier aircraft are determined more directly by the number of landing cycles and pressurization cycle. **Table 4** shows the "economic design life objective" established by Boeing for four of its widely used commercial aircraft. Note that for each airplane a twenty-year service-use objective is set. Objectives for landing cycles vary, however, depending on anticipated use patterns (short flights-many landing vs. long flights-few landings).

TABLE 4
ECONOMIC DESIGN LIFE OBJECTIVES
FOR FOUR AIRCRAFT

Aircraft	Landing Cycles	Hours	Years
707	20,000	60,000	20
727	60,000	50,000	20
737	75,000	51,000	20
747	20,000	60,000	20

Boeing Commercial Airplanes, 1989.

Figure 2 shows for nine aircraft types the number of landing cycles made by the high-time airplane compared with the economic design life objective for that aircraft type. In many instances, the landing cycle for the high-time airplane exceeds by a considerable amount the

cycles established initially as an objective. This does not mean, of course, that these aircraft are in danger of falling apart at any moment. Each of these aircraft has been periodically inspected and maintained, with worn parts and systems replaced, as these landing cycles were accumulated. "Economic life objective" is simply a concept established during the design of the airplane. The objective is not set as a limitation on the airplane.

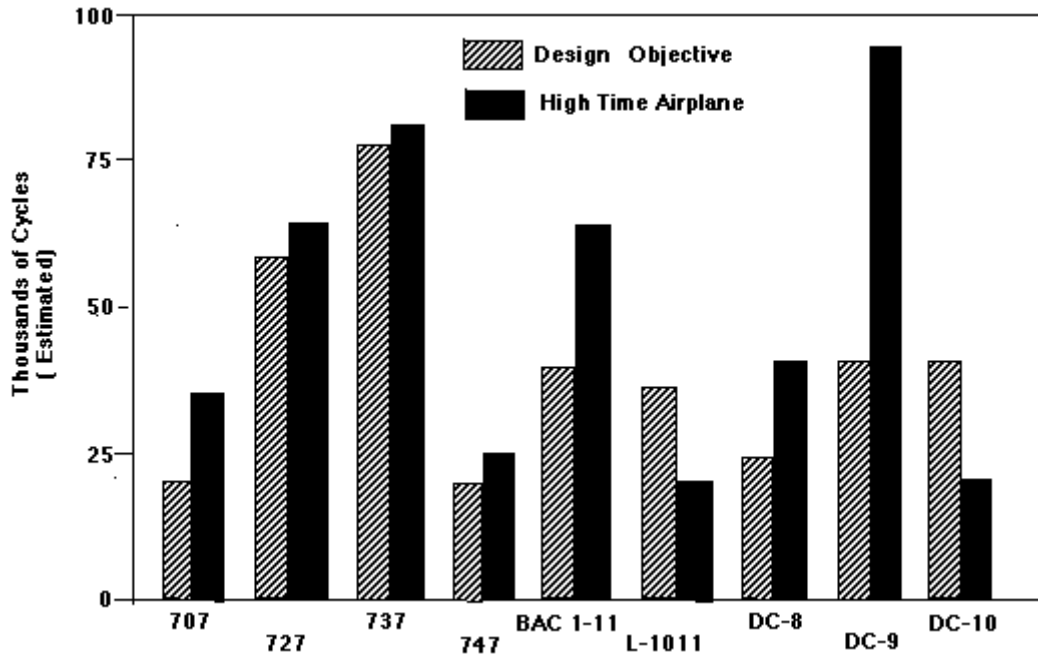

Figure 2 Landing cycles for selected active air carrier aircraft.

As the commercial aircraft fleet in the United States ages, and as landing cycles increase, the burden on maintenance grows. The maintenance industry today is large and continues to grow in parallel with the expansion of airline operations. **Table 5** shows that over 50,000 mechanics are employed today, with a total cost for maintenance operations which exceeds \$6 billion per year. At the present time, about eleven percent (11%) of maintenance activities are contracted, with the major part of maintenance being accomplished by the airlines themselves. The \$6 billion cost for maintenance shown in Table 5 represents an outlay of some eleven percent (11%) of airlines operating revenues. Maintenance is expensive.

TABLE 5
MAINTENANCE PARAMETERS
FOR U.S. SCHEDULED AIRLINES

Mechanics employed = 51,233
 Maintenance expenses = Over six billion dollars
 Major carriers contract 11% of maintenance work

ATA (1988); Office of Technology Assessment(OTA) (1988)

Maintenance costs as a percentage of total operating costs is important but it may not be the best indicator of maintenance expense. The percentage will be influenced by the contribution to operating costs made by fuel costs and non-maintenance labor, both of which are known to have wide fluctuations. Therefore, maintenance expense trends for specific aircraft are considered more meaningful. **Figure 3** shows the average flight equipment maintenance expense for the B727-200 fleet. This shows that for each revenue aircraft departure since 1982, there has been an almost steady increase in maintenance expense.

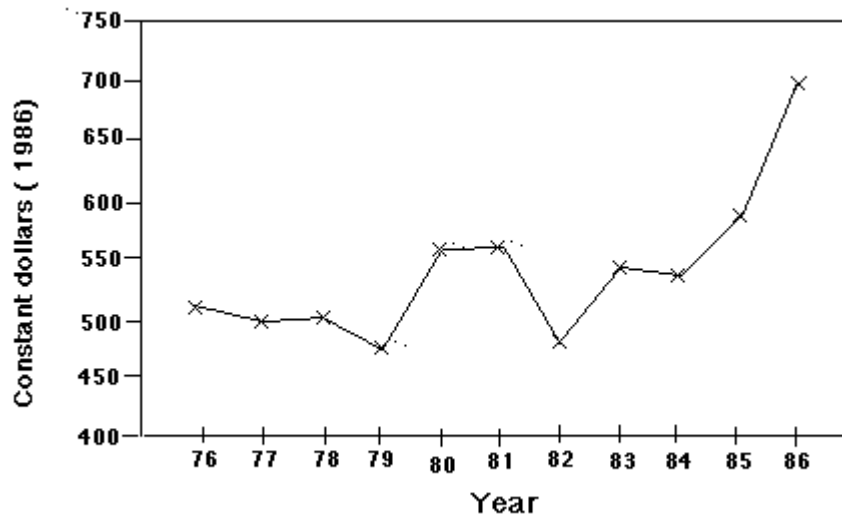

Figure 3 Average flight equipment maintenance expense for B727-200 fleet.

In summary, data describing the U.S. aviation industry and its supporting maintenance base show an expanding industry in which the average age of aircraft used both by commercial airlines and by general aviation increases each year. There is a corresponding increase in maintenance costs. Both of these trends point to a need to ensure that aircraft maintenance, and the use of maintenance personnel, is conducted as efficiently as possible. The safety of the public and the economies of air transportation support programs to optimize maintenance operations.

References

- Federal Aviation Administration. General aviation activity and avionics survey. FAA Report No. FAA-MS-87-5. Washington, DC. December 1987.
- U.S. Congress, Office of Technology Assessment. Safe skies for tomorrow: Aviation safety in a competitive environment. OTA-SET-381. Washington, DC. Government Printing Office, July 1988.
- Air Transport Association of America. Air transport 1988 - the annual report of the U.S. scheduled airline industry. Washington, DC. June 1988.

Federal Aviation Administration. Briefing by Western Region. 1988.

Federal Aviation administration. FAA aviation forecasts - Fiscal years 1988-1999. FAA Report No. FAA-APO-88-1. Washington, DC, February 1988.

CONCLUSIONS AND RECOMMENDATIONS

The attendees at this two-day meeting had diverse allegiances, some being from the Federal Aviation Administration and the National Transportation Safety Board, some from aircraft manufacturers, others from the airlines, and others from remaining segments of the industry. As a result, many of the suggestions and recommendations which were offered were specific to that part of the industry represented by the attendees. However, some themes are apparent. The following recommendations represent a grouping of attendees suggestions according to these themes, with specific recommendations included within each major topic. Some of the recommendations are directed to the FAA; others toward the industry itself.

Communications

"Communication" formed some part of more recommendations than for any other topic addressed during the meeting. Comments were made by several members that even if the meeting accomplished nothing else, it served a very useful purpose by allowing representatives from all parts of the industry to get together and exchange views. Credit was given to the FAA for providing the forum in which this exchange could take place. Apparently the changing structure of the airline industry as it proceeds through deregulation has seriously disrupted industry networking. In earlier days, there existed a more effective communication network among airline operators, a network which also included manufacturers. This network does not seem to exist today, at least not to the same extent, and attendees voiced a real need either to rejuvenate the network or replace it in some manner. At the conclusion of the meeting, several attendees expressed a desire that the FAA not let this meeting be a one-of-a-kind affair. They wished to see some comparable get-together occur at least once a year.

The purpose of a periodic meeting would be to review maintenance problems and to spread word through the industry concerning new procedures and new technologies. One attendee stated, "If we have a safety situation and have options to resolve the problem, everyone should know about it."

Another expressed need, as part of the communication entreaty, was for a data base of maintenance information to be shared throughout the industry. There does not exist at this time any central repository containing assembled knowledge concerning maintenance procedures, technologies, equipment capabilities and limitations, unique aircraft problems, personnel variables, and so on. This need is supported by the circumstances surrounding the loss of an engine by a DC-10 during take-off several years ago. In this case, apparently one operator had learned that removing the engine and pylon together for maintenance could cause cracking of part of the structure at the attach point between the pylon and the wing. While this airline

obviously stopped using the procedure, work of their experience did not become immediately available to the rest of the industry.

The point was made that manufacturers need to team with aircraft operators in the collection of necessary data for an industry data base. By so doing, both parties would have better insight into the kinds of maintenance errors being made, the most frequent types, and aircraft design features relating to increased error.

The importance of continually striving to ensure good communications between airline management and the labor force was noted. Morale of the workforce can be influenced positively by letting workers know when a job has been well done. Also, the workforce should have some insight into the problems being faced by management. For example, one airline had numerous occurrences of engine oil leaks, some involving inflight shut-downs and unscheduled landings. While airline management was quite concerned over these occurrences, it apparently viewed them as a series of unrelated mechanic discrepancies instead of a systemic problem. As appropriate information and concern was not passed to the workforce. Consequently, maintenance personnel did not give this issue the full attention it should have received.

Finally, note was taken of the fact that not all airline operators attend industry meeting, such as those sponsored by the Air Transport Association. In fact, the point was made that operators who do not attend industry meetings are the same ones who are not achieving the same level of maintenance quality as other operators. The communication value of such meetings is undeniable. Some means must be found to encourage all operators to attend these meetings.

Recommendations

1. The FAA should sponsor at least one more meeting addressing human factors and personnel problems in aircraft maintenance and inspection. All airline operators, including regional carriers, should be invited. One topic would be to assess the desirability and appropriate means for institutionalizing this industry meeting. While there might be some invited speakers to discuss new technologies or comparable matters, a good part of the meeting should be set aside for panel discussions led by an industry member and open to all other members.
2. The FAA should consider means for encouraging or developing a data base of industry information concerning maintenance technologies, procedures, and problems. An FAA-sponsored Clearinghouse for Maintenance Information would be of great value to the industry. Apparently over the last several years the Electric Power Research Institute (EPRI) has been nuclear power plants. Possibly a representative of EPRI could describe this data base, and methods for developing a similar one, as one item in the FAA/industry meeting described in Recommendation 1.

Personnel

Recruitment/Availability. The airline industry has expanded rapidly in recent years with a consequent need for larger numbers of qualified maintenance and inspection personnel. Resources to meet these new staffing requirements have not always been there. This is true both for trunk carriers and for regional airlines. In fact, regional airlines may be even harder hit as some of their personnel move to major carriers. Commuters then must fill their ranks from maintenance schools, the military, and from fixed-based operators. The result is that, both for major carriers and for regional carriers, the workload is expanding and the experience level of maintenance personnel is decreasing. To illustrate, the following statistics apply to Inspectors for one major carrier.

46% have less than three years

22% have less than two years

12% have less than one year

This is in an operation in which the Manager of the Inspection Department estimates that it takes an inspector two years to become effective; six years to become efficient.

The result of the lowered level of experience for inspectors and mechanics is that work is done more slowly and more mistakes are made that must be corrected. An additional burden is placed on the inspector force.

Training Much discussion during the meeting centered on adequacy of training for maintenance personnel. Much of the problem was attributed to requirements for training established by the FAA in Part 147 of the Federal Aviation Regulations. Some parts of the initial training covered by Part 147 deal with woodwork, welding, fabric skin repair, and radial engines, all topics of little consequence for the carrier jet fleet. The A & P curriculum was generally viewed as inadequate.

Another problem is that avionics technicians who have completed an FAA-approved avionics school are treated differently than those who have completed an airframe and power plant school. For example, an Avionics Manager cannot be Director of Maintenance without acquiring an A&P license. However, an A&P license alone qualifies one to become Director of Maintenance, while understanding little about the microprocessors, integrated circuits, and sophisticated avionics which are critical to modern aircraft.

The general dissatisfaction with Part 147 should be tempered by the knowledge that the FAA currently is reviewing this document for change. One member of the training establishment offered the suggestion that during this period of change consideration be given to expanding coverage to include topics covering professional ethics, professional communications, and personal commitment to one's job. He felt that such training could be of considerable value in expanding the professionalism of maintenance personnel in the next decade.

One suggestion for improvement was that training be expanded to include certain post-graduate specialty programs. Such programs would be added to the existing curriculum and would be elective. This would be one way of dealing with such issues as the fact that at this time no training is required for helicopter maintenance. Also, advances in nondestructive testing (**NDT**) technology and procedures have exceeded the number of qualified NDT personnel. One of the

graduate courses might include use of such advanced test systems.

Training for maintenance personnel is ongoing, extending to some extent throughout their career. For example, one operator has five percent (5%) of the inspector force in formal training at all times. During such training, maximum use should be made of new training technologies. For instance, videotapes produced in-house are now being used by one carrier to illustrate compliance with latest Airworthiness Directives. This carrier is quite pleased with results of its video program. This and other technologies should be used industry-wide.

Licensing/Certification. The issue of "type rating" mechanics in different aircraft was raised as means of ensuring that a mechanic's qualifications are appropriate for the aircraft on which he works. Aircraft are becoming more sophisticated; helicopters are extremely complex; and avionics systems represent the very latest in technology. At this time, airline operators, in keeping with their insurance coverage, limit the duties of certain mechanics to their experience level. However, no regulation covers this. A suggestion was made that current licensing procedures, particularly with respect to avionics technicians, be reviewed and that consideration be given to the establishment of new levels of licensing and certification. The Canadian Aviation Regulations, which require licensing by aircraft type for mechanics, was cited as a possible model.

Discussions among all attendees brought forth pros and cons concerning increased licensing or certification. Concern was expressed over additional layers of regulation. However, if new licensing techniques would add to the quality of maintenance, they would meet with approval.

Recommendations

1. The current review of Part 147 should be expedited as feasible. Results should include provision for specialization training as a formal and advanced part of the curriculum of approved schools. As part of this effort, consideration should be given to current licensing procedures for avionics technicians. These procedures should be revised consistent with the growing role of avionics personnel in aircraft maintenance. The result of all of this will be a better entry product into airline operations and the resolution of some current job problems.
2. Consideration should be given to ways of promoting aviation maintenance as a career. The FAA can play a useful role by encouraging or actually developing some promotional materials. Are brochures describing aviation maintenance available for distribution at the high school level? Is there an up-to-date video which describes the profession and its rewards?
3. Should there be another meeting of this type, as recommended earlier, "training technology" should be a key topic. The FAA should invite some expert who is familiar with all of the latest training systems to conduct this session.

Job Pressures

Time pressure, also known as "gate time," is considered by many to be the most important factor affecting performance of mechanics and inspectors. Management and the mechanic force have the pressure of getting the airplane to the gate on time. Inspectors have the pressure of being certain the aircraft is airworthy. The conflict between these two driving pressures can produce an adversarial relationship which does not benefit either side.

Ground time available for maintenance also can produce job pressures. Striving for higher aircraft utilization means that more maintenance must be accomplished in fewer hours, with these hours frequently being at night. Under these conditions, the need to meet an early a.m. departure time can again cause friction between the maintenance and inspection groups.

The consensus is that inspectors must be insulated from production and from all the rest of maintenance, yet these groups must complement one another. In some operations, this insulation is expressed in writing and supported verbally. Yet the pressure for on-time service inevitably will cause some group dissonance. The objective is to insure that such dissonance does not seriously impact the performance of either group. One way, of course, is to have inspectors and mechanics report to management through different organizational chains. Even here, however, the pressures remain.

Another factor impacting job performance is fatigue. Young mechanics just out of school who may be starting a family find it difficult to do so on entry wages. As a result, they take a second job and are quite fatigued by the end of their maintenance shift, particularly if it is the night shift. In other instances, the shortage of mechanics requires overtime work which itself contributes to fatigue. All of this tends to make maintenance personnel more error-prone.

Recommendations

1. All parties should consider ways to insulate inspectors from management and from the rest of the Maintenance Department. Inspectors should not feel the "gate time" pressure. With older aircraft, it is particularly important that inspector performance be of the highest quality. This might mean a review of inspection tasks to see how many, if any, might be shifted from ongoing maintenance activities to the longer schedule maintenance visits, where gate time is a more distant concept. Supervisor personnel should be given some training in the detection of fatigue and its insidious effect on work performance. If fatigue appears to be a constant problem, some rescheduling of maintenance activities might be considered. The first step, of course, is to determine whether fatigue is or is not a problem.

Performance Improvement/Job Design

Many individual variables can be considered in a program to improve performance for maintenance personnel. A human factors scientist in attendance indicated that, for inspector

performance, such variables include conspicuity of the signal (flaw), signal-to-noise ratio, length of inspection period, social atmosphere, and others. Pursuing this list, in effect, constitutes job redesign, which has high potential for performance improvement. A proper job redesign, however, would not consider each of these variables separately.

A full job design, or redesign, would begin with a specification of overall system objectives and the contribution of the human. The human would be considered as one system component with the designer's job then being one of matching other system elements to the human. This is done on the basis of a task analysis of operator activities. The task analysis points to man/machine mismatches, workloading of the human, and many other variables related to performance. A meaningful job redesign requires a task analysis as a starting point.

An important product of a task analysis is a description of the kind of performance feedback required and the manner in which it should be presented. Human factors scientists noted that feedback must be complete, relevant, and timely to be effective. However, the requirement for feedback is highly dependent on the nature of the task. In one study for feedback is highly dependent on the nature of the task. In one study cited, performance in a visual inspection task was markedly improved simply by providing feedback concerning the inspector's performance more rapidly. The importance of feedback to job design was very apparent.

One attendee noted the need for a research center, or at least a coordinated research effort, which might be dedicated to studies of job design and aircraft design and the contribution of each to maintenance error. He noted that there is no place where regulatory agencies, operators, and manufacturers can team together to examine concepts and other variables assumed to play a part in maintenance effectiveness.

Recommendations

1. Consideration should be given by the FAA to an effort in which a task analysis could be conducted both of maintenance performance and inspection performance. To be useful, such an analysis need not describe performance on a second-by-second basis. It should be done in sufficient detail, however, that the physical, perceptual, and mental aspects of the task can be reviewed. Input/output requirements and task loading must be defined. In all, the task analysis should be conducted in sufficient detail that results can feed directly into computer-based efforts to model maintenance and inspection performance.
2. The suggestion concerning development of a research center where maintenance concepts might be studied in detail warrants careful review. In as much as either the FAA Technical Center or the Civil Aeromedical Institute could undertake such a program, no new facilities would be needed. An additional task element to either facility, with appropriate guidance and funding, could initiate this research center.

Maintenance Information

Effective maintenance is predicated on a continuing flow of information. The information supporting maintenance must be timely, accurate, appropriate to user requirement, and in a form readily understood. A number of comments indicated concern over the adequacy of maintenance information today.

The demand for new generation aircraft apparently has resulted in aircraft being placed in service before a full technical support program can be developed. One consequence, according to regional air carriers, is that maintenance manuals are inadequate. They leave much to be desired in terms of wear limits, damage limits, repair schemes, and adequate or accurate wiring diagrams. As a result, operators must frequently make requests of manufacturers for repair limits, repair schemes, and other relief. This information is only forthcoming after it has been developed by engineers and approved by FAA representatives. This causes delays in the provision of good technical information and is a source of frustration. Maintenance personnel are precluded from proceeding with subjective repair judgments which might conflict with later maintenance documentation.

Where a number of individuals are doing the same work, standardization of information is essential. Although there is an ATA system which specifies a standard format for finding material in a maintenance manual, the material itself differs among manufacturers. Maintenance manual, the material itself differs among manufacturers. Maintenance and inspection manuals themselves are not standard in terms of shape, size, of format. Standardization of language requires additional work. For example, turbine temperatures for different aircraft are expressed as: EGT, T4, T5, TIT, and TOT. Although areas of pickup on the engine may differ, all of the figures produce the same information. Standardization of format and language would be of value.

The aviation industry well recognizes the need for proper maintenance information. In an effort to improve the situation, several years ago the Douglas Aircraft Company developed an "Advanced Maintenance Information Packet." In this, maintenance tasks were presented in sequence, with accompanying graphic presentations, with cautions and warnings, fit into the sequence, and with tools and special equipment identified prior to the task. Tests showed a considerable reduction in errors when this packet was used.

The Boeing Company, in another program to improve the situation, developed an Automated Customized Task Card. In this system, material from the maintenance manual is computerized, thus eliminating the task card reader and the microfilm reader/printer. Material now is accessed directly from the computer and is more readily available. Errors encountered previously in preparing data for the mechanic have now been eliminated.

Many attendees noted issues with Service Bulletins. These bulletins, prepared by the manufacturer and reviewed by the FAA, are used to identify aircraft problems and maintenance needs after the airplane has entered service. They are prepared by engineers and can be complex, often using language more meaningful to engineers than mechanics. The Boeing Company is

attempting to improve these bulletins by using "**Simplified English.**" Apparently, however, much remains to be done by the industry at large with respect to Service Bulletins.

In an effort to extend the state-of-the-art of information presentation, the Air Force has been working for some years on an Integrated Maintenance Information System in which needed information is provided to a mechanic directly at the flight line through use of a video display. Through this display, the technician can access a number of different data bases to support his immediate requirements. In the preparation of this system, scheduled for field testing within the next few years, the Air Force has addressed many of the human factors issues involved in preparation and delivery of maintenance information.

Recommendations

1. Any program to improve maintenance performance must address the issue of adequacy of maintenance information. Technical documentation to support maintenance must be accurate and timely, must meet the needs of the user, and must be presented in a completely intelligible format. The FAA should review its surveillance of maintenance manual preparation to ensure that proper technical data are supplied to operators, particularly concerning wear limits, damage limits, and repair schemes.
2. The FAA should sponsor a program to collect and categorize information on research activities pertaining to maintenance data. We know of other industry initiatives or of relevant research outside the aviation industry. Should there be another meeting addressing human performance in aviation maintenance, one session should be devoted entirely to "Requirements and Advances in the Improvement of Maintenance Information."

Appendix A: Meeting Presentations

FAA REGULATORY REQUIREMENTS FOR AIRCRAFT MAINTENANCE AND INSPECTION

*Raymond E. Ramakis
Manager, Aircraft Maintenance Division
Federal Aviation Administration*

The attention of this meeting is on the human factors of aircraft maintenance and inspection. Rightfully so, since this is where the problems are. If we find some failure in aircraft design, we can issue an Airworthiness Directive and thus correct the situation. Procedures for dealing with design issues and aircraft faults are clearly specified by the FAA. It is the area of human factors that has not been touched.

I would like at this time to review in very general terms the regulatory requirements established

by the FAA for aircraft maintenance and inspection and note the human factors implications of these regulations.

In the certification process for a new aircraft, regulations require the manufacturer to develop an appropriate maintenance program. Basically, he is required to provide an airplane manual and a continued airworthiness program for his airplane.

The basic maintenance and inspection program, for large transport-category airplanes, is developed through a Maintenance Review Board and a failure-fault analysis system. This system allows the manufacturer, the Federal Aviation Administration, and the airlines to work together in shaping a maintenance plan. The result is the initial program for maintaining an airplane. The process offers the manufacturer an excellent method for establishing a program that is acceptable both to the airlines and to the FAA.

As the aircraft enters revenue service, it comes under Part 121 of the Federal Aviation Regulations. Within Part 121 is Subpart L, "Maintenance Requirements," which contains the federal regulation that governs, in a broad sense, what airlines can and cannot do with that aircraft. These regulations are adopted and reviewed by the FAA through what we call Operations Specifications. This allows the development of a complete and comprehensive maintenance program which has been put together and agreed to by all parties.

The final document resulting from the above process is called a Continuous Airworthiness Maintenance Program. It covers every aspect of maintaining that airplane from A to Z - not a stone is left unturned; but it does not address the human process. The document describes the intervals between maintenance checks; that is, when a "A" check is required, when a "B" check is required, etc. It describes all programs that the airline must comply with in order to be in accordance with the regulations. But, again, it does not address the human process.

Federal Airworthiness Regulation Part 121 does speak, in broad terms, of the requirement for a certificate holder to ensure that competent personnel and adequate facilities and equipment are provided for the performance of maintenance. This is the extent to which human factors are addressed. Ideally, interpreting those broad terms fully means that when an aircraft comes in for a check, there will be an abundance of well-trained mechanics and inspectors, available in well-lighted, well-heated and cooled hangars with plenty of ground time to accomplish the required maintenance and inspections.

Unfortunately, the world described above does not exist in reality. Aircraft typically fly all day, with utilization rates of 8 to 12 hours per day, and are scheduled for maintenance late at night. Maintenance personnel, in turn, face a demanding schedule to ensure that the airplane is available to meet the next schedule. The nature of the flight leg, since deregulation, in which "hub and spoke operations" are used, adds to the problems of the mechanic.

The constant pressure of ensuring that flights maintain an on-time schedule, partially caused by the Department of Transportation, has the inevitable result of placing heavy pressure on maintenance operations and increasing the likelihood that maintenance will be hurried and possibly inadequate.

Training of maintenance personnel is another matter for consideration. The quality of training varies through the industry. Some airlines have training programs that would rival a university,

with considerable time and resources invested. In other instances, training is not nearly as good, although it will meet minimum standards established by the FAA.

Facilities built for aircraft maintenance bring their own problems. These structures are large simply because they have to hold large aircraft, test stands, and other maintenance equipment. They do not lend themselves to good environmental control. Even the newest hangars used by some of the largest airlines are very cold during the winter and very hot during the summer. In addition, the lighting may or may not be optimum for the kind of maintenance being performed. However, all of these facilities are completely in compliance with FAA regulations.

The final factor for consideration is that of economics. Aircraft maintenance definitely is affected by the financial condition of an airline. Facilities, tools, and the work environment are negatively affected in an airline with financial difficulty. This is unfortunate, but it is true. All too frequently, financial attention is given first to operations, next to marketing, and finally to maintenance. Yet, even with an austere maintenance activity, an airline can remain in compliance.

Considering that all airlines essentially are in compliance with FAA regulations, do we have a problem? Unfortunately, there are indications that we do. There is, of course, the well known Aloha Airlines accident. There also are instances, in which human factors definitely played a role, that could have resulted in an accident but fortunately did not. In one case, discussed earlier, a 737 was found to have a number of cracks, one of which was 55 inches long. This was covered by three layers of paint. A related Airworthiness Directive said, "do a visual inspection." The visual inspection, of course, was not adequate to reveal these cracks even though there was a slight bulge (3/64") under the three layers of paint. The problem was only noted when the paint was stripped.

In the case of a DC-9 accident at Minneapolis some time ago, there were spacers in the engine that were to be replaced if cracked. The results of the accident's investigation by the National Transportation Safety Board indicated that, although this could not be proved without doubt, there were cracks in the spacers and the spacers were not replaced. The investigation determined that there were no training records for the person doing the inspection. There also were no records indicating whether his eyesight was good or bad.

When maintenance programs fail in some manner, as we have discussed above, the FAA must assume a measure of responsibility. Airworthiness Directives and other FAA messages to industry are perhaps not as practical as they could be or as well written as they should be.

FAA regulations also deal somewhat superficially with training requirements for maintenance personnel. For example, consider the training for "required inspection personnel." These are the individuals who inspect an aircraft area where maintenance, if done improperly, could lead to a catastrophic result. In effect, these inspectors provide a double set of eyes to ensure adequacy of maintenance. While this position is of obvious importance, the regulation simply states that "each certificate holder must ensure that persons who perform required inspections are appropriately certificated, properly trained, qualified, and authorized to do so."

Finally, keep in mind the inspector who may be on top of an airplane at 3:00 a.m., under cold conditions, and working his way down lines of rivets that in all might be 1,000 feet long. This is

the individual who must perform his job with complete precision if the aircraft is to be totally safe. We must consider these human factors issues and not build potential errors into the system through neglect of them.

MAINTENANCE AND INSPECTION ISSUES IN AIRCRAFT ACCIDENTS/INCIDENTS, PART I

*Barry Trotter
Aviation Safety Investigator
National Transportation Safety Board*

The data bases maintained by the National Transportation Safety Board include listings of aircraft accidents and incidents related to maintenance and inspection factors. For Part 135 operators, those offering air taxi and charter services, approximately 200 such events have been recorded for over the past ten years. This includes those offering both scheduled and unscheduled services. For Part 121 operators, the commercial air carriers, the number is 49.

In terms of any statistical assessment, the above numbers are quite small. However, these numbers must be approached cautiously since they may represent only the tip of the iceberg. In the sequence of events leading to any aircraft accident, one may find that a maintenance or inspection lapse played some part, even though the lapse might not represent a primary cause of the accident.

An example of an event in which inspection lapses played an important part is provided by the account of a commercial 727 which lost an engine, in the literal sense, while approaching San Diego several years ago. In this case, water from a leaking toilet caused a block of blue ice to form by the engine, causing the engine to break loose from the airplane. In a review of the circumstances leading to this accident, it was found that the toilet had been leaking for some time and no one had picked it up during any of a number of inspections of the aircraft. These included routine inspections as well as the customary preflight walk-around by the flight crew. Why the leak was not discovered is not easy to explain since the blue lavatory water had caused a blue streak back over the aircraft and over the wing. On examination of the aircraft it was found that the stain had been there for some time.

Some inspection problems arise as a result of complexities in the regulatory process which overlies aircraft maintenance. An example is provided by a 737 airplane which was delivered to a commercial airline in 1969. Subsequently it was acquired by another airline, which completed the mandatory Airworthiness Directive inspection of exterior rivets in May of 1988, about five months ago, and was given a clean bill of health. This Airworthiness Directive did not require inspection down to Stringer 14 below the window line. However, there are Service Bulletins, which are not mandatory in the regulatory sense, covering that area of the aircraft. Obviously, the new operator was not informed concerning whatever compliance the previous operator had made with these Service Bulletins.

When the aircraft was stripped for repainting recently, a 12-inch crack was discovered in the Stringer 14 area. This crack had nicotine stains and other buildup indicating it had been there for

some time. Along the line trailing this crack were multiple smaller cracks, adding up to approximately a 55-inch area with a potential for a serious rupture of the aircraft's structure. We do not believe that these cracks appeared between May and the time aircraft was stripped for painting. In order to learn more about this, the NTSB has had that part of the aircraft cut out and brought to our laboratory for in-depth study.

Other inspection issues arise from procedures established by operators to conduct specific maintenance activities. In some cases the procedure may be entirely adequate, but the next higher procedure - the one designed to ensure that maintenance personnel comply with the basic procedure - is inadequate. In a classic example, an L-1011 airplane was proceeding from Nassau to Miami when it suffered multiple engine failures due to loss of oil. Chip detectors had been replaced in the engines with out the required O-rings, and the oil simply ran out.

In the procedures used for replacing chip detectors, a maintenance supervisor would remove the O-rings from a sealed packet, put them on the chip detector, and hand it to the mechanic in exchange for the chip detectors removed from the aircraft. In the case at hand, the supervisor was not present, so the mechanic simply picked up a set of chip detectors having no O-rings in place and installed the detectors in the engine. While the usual practice of the airline precluded such an occurrence, there was no specific procedure designed to prevent this from happening. In the case of the mechanic, one can only surmise that perhaps boredom and the repetitive nature of this process might have played a role.

The use of Service Bulletins to define maintenance requirements deserves a special comment here. Service Bulletins, prepared by the manufacturer and reviewed by the FAA, are used to identify aircraft problems and maintenance needs after an airplane has entered commercial service. Service Bulletins often advise compliance if an operator is engaged in a particular type of operation and also suggest a schedule for compliance. Service Bulletins are not mandatory.

A problem arises when an aircraft is not large enough to have an engineering staff capable of evaluating the many Service Bulletins that arrive to select those which address particularly the type of flight activities in which the operator is engaged. There may also be issues of economy. In any event, many Service Bulletins may not get proper attention and thus, when the airline is acquired by another operator at some later date, the new owner has only a hazy idea of the maintenance condition of his new aircraft. He may not have specific information concerning which Service Bulletins were done and which were not done.

On one occasion, one cargo airline acquired an aircraft from another carrier and received all maintenance records in a cardboard box. In the changeover, records were not systematically reviewed and some procedures, including the mandatory Airworthiness Directives, were not followed. One Airworthiness Directive required trailing edge flap spindles to be replaced after 18,000 hours of service. While making an approach in this airplane, two of these spindles broke due to stress corrosion, causing serious flight control difficulties. In the investigation it was found that the operator, unaware of the 18,000 hour requirement, had scheduled replacement on their normal schedule to occur at 28,000 hours. They were running approximately 10,000 hours past the time for replacement required by the Airworthiness Directive.

The above examples illustrate some of the aviation accidents and incidents reviewed by the National Transportation Safety Board which have been caused, at least in part, by problems in

maintenance and inspection. In general, however, one must conclude that the system, as it now exists, works pretty well. Millions of hours are flown each year with very few accidents. Nonetheless, there are two exceptions to this system which I think should be noted. One is the individual, whether it be an airline operator or a single mechanic, who is not performing to the standards of the rest of the industry. In this case, I believe it is incumbent upon the FAA surveillance system to be able to spot this individual and implement a program to endure that his work improves. This is especially true for the airline operator. For the individual mechanic, the responsibility falls more upon the airline management. However it is done, we must have consistency of maintenance and inspection through all of aviation. In general, this will involve more than simply "complying with minimum FAA standards."

The second exception concerns the phased maintenance program in which a full maintenance activity, such as a D check, is spread across 52 blocks over eight years. This means that the airline operator does not get a complete look at any one time at any of the aircraft's systems. It also means that seven years in a high cycle operation may pass before the operator looks again at a critical portion of the aircraft. This may simply be too long to ensure adequate surveillance of developing aircraft problems.

The National Transportation Safety Board conducts extensive investigations of aircraft accidents and incidents of the type I have just described. Some of these events can be traced to the performance of personnel conducting maintenance and inspection operations. Although aircraft accidents directly traceable to lapses in maintenance and inspection are rare, they warrant continuing attention by the aviation industry.

MAINTENANCE AND INSPECTION ISSUES IN AIRCRAFT ACCIDENTS/INCIDENTS, PART II

*James W. Danaher
Chief, Human Performance Division
National Transportation Safety Board*

We at the National Transportation Safety Board are visited frequently by persons wishing to use our data systems as they seek answers for a variety of questions in aviation. Usually the visitors come away somewhat disillusioned and with considerably less than they had hoped for in the way of answers. The statistics we maintain, while they can be very useful, just do not always offer complete answers for aviation questions. This is particularly true concerning maintenance and inspection. The number of accidents and incidents in which maintenance and inspection errors are cited as causal or contributory factors is quite small. This small number of recorded events does not mean that such occurrences are not significant and pervasive. Rather, it merely indicates that accidents and incidents are not a sensitive measure of the significance of the maintenance and inspection problems.

From a philosophical standpoint, we must realize that an accident or incident is at the end of a sequence of events which, in some respects, could be thought of as a complete breakdown of our aviation system. In such case, all of the measures and safety margins which have been contrived to prevent accidents have broken down; in that same sense, a mid-air collision represents the

ultimate breakdown in the traffic control separation system. In the chain of events leading to an accident, maintenance errors generally happen way upstream, with many opportunities to interrupt the chain and prevent the accident. Accidents thus can be seen to be a very poor indicator of the real frequency of maintenance and inspection errors.

Earlier during this meeting, the comment was made that the aviation community has barely scratched the surface in looking at the human element in maintenance and inspection. This certainly appears to be true. A look at the Safety Board's categorization of errors in its aviation accident and incident data system indicates there is only limited coding capability to realistically tally the errors that occur in maintenance and inspection tasks and which might have contributed to mishaps.

Quite a bit has been said about the environmental aspects of maintenance, i.e., the excesses of temperature, vibration, noise, illumination, precipitation - all those workplace environmental factors that can adversely affect human performance and could contribute to errors of omission and commission. These undoubtedly are important factors influencing performance. However, I submit that we should not focus solely on these environmental factors in our study. One of our investigators returned from Aloha Airlines accident and stated informally that "the problem isn't so much a coveralls problem as it is a coat and tie problem." It was his belief that the mechanic and inspector, who at times work under adverse conditions, often bring a high level of motivation and professionalism to the job which helps them cope with such conditions and sustain good performance. What is required is a more comprehensive approach to providing the maintenance team with the full wherewithal to do its job. All of the key elements in the aviation industry must contribute to this wherewithal, including the manufacturer who provides, the air carrier maintenance department which establishes specific procedures and tasks, the air carrier management which is responsible for procurement of the best maintenance facilities and test equipment, and carrier production personnel who must work closely with maintenance to strike a balance between the sometimes conflicting time demands for proper maintenance and the pressures to meet flight schedules. All parties must work together to support the maintenance and inspection team.

Another factor affecting the quality of maintenance and inspection is the extent to which information about operating experience is disseminated through the industry. The physical separation of an engine from the airframe of a DC-10 during takeoff from Chicago several years ago serves as an example here. In this case, the manufacturer had recommended earlier that, when removing and replacing the wing-mounted engine for maintenance purposes, the engine should be removed first in one operation and the pylon removed next in a separate operation. This was a labor intensive activity. The operator, when considering personnel time and costs involved, obviously reviewed the procedure to determine the best and, hopefully, easiest way to accomplish this engine change. The NTSB accident report notes that raising and lowering the engine and the pylon as a single unit reportedly saved 200 man-hours of maintenance time per aircraft. Also, and quite important from a safety standpoint, it reduced the number of disconnects - that is, the hydraulic lines, fuel lines, electrical cables, and wiring - from 79 to 27. In all, there were strong incentives to work with the engine and pylon as a single unit. On the other side, however, moving these two components as a unit was quite a task. The movement of

that weight up and down with a forklift, and the precision with which it had to be done, was difficult at best. In retrospect, one can say that the engineering staff should have taken a more detailed look at the advisability of such a procedure and provided an assessment as to the potential for damage in implementing it. However, this was not done.

During the same period of time, another airline was considering this same procedure for changing the engine on its DC-10 aircraft. This airline also decided that movement of the engine and pylon as a single unit would be advantageous because it would save considerable labor costs. Shortly after implementing this procedure, however, they found, somewhat fortuitously, that they had cracked part of the structure at the attach point between the pylon and the wing. Understandably, they immediately stopped using the procedure but they did not advise other DC-10 operators or the aircraft manufacturer of their experience. Whether they should have done so is debatable. They did not, in any event, have an obligation to apprise other airlines of their experience.

The changing dynamics of the airline industry, in this period of deregulation, seem to have caused a decrease in industry "networking." Old timers in the airline industry contend that in earlier days there was much more frequent dialogue among operators; in other words, a more cooperative grapevine. It would be interesting to speculate about informal means that might have been implemented to spread the word among DC-10 operators and head off the catastrophic accident at Chicago.

Closely allied to the topic of industry networking is that of FAA surveillance. Should the FAA have known of the DC-10 engine experiences? If aware of it, should they have been responsible for seeing that this information was made known immediately to all airlines? For good reason, the Federal Aviation Administration is one step removed from direct maintenance tasks. The FAA, understandably, is reluctant to tell maintenance professionals how to do their jobs. Their surveillance of maintenance and inspection practices is intended to determine whether the organization has a structure which is conducive to accomplishing the required maintenance; whether the people in key positions are qualified; and whether the policies, practices and systems in place are adequate to provide a reasonable assurance that the intent of FAA regulations will be maintained. Whether FAA surveillance should be expanded is a topic for consideration. There are pros and cons.

Finally, there is the matter of communication between airline management and the labor force. During the nearly two-year period before the L-1011 flight from Nassau to Miami started gliding down to the Atlantic, the airline had twelve occurrences of engine oil leaks as a result of improperly installed chip detectors or o-ring seals. Of these twelve, eight involved inflight engine shutdowns and seven necessitated unscheduled landings. Airline senior management, maintenance management, and supervisors were aware of these occurrences, but apparently interpreted them as unrelated mechanic discrepancies rather than a systemic problem. Although minor changes were made in some work cards and procedures, and these incidents were reported upward in the management structure, there appeared to be no flow of information back to the general foreman level. The working maintenance team remained uninformed regarding the magnitude of the chip detector installation problem.

In summary, I submit that across the spectrum from the manufacturer to the working mechanic

and inspector, including immediate supervisors and foremen, the engineering staff, top management, and FAA surveillance personnel, everyone needs to take a hard look at the human factor in the maintenance function. Maintenance and inspection involves many very labor intensive tasks which are necessarily susceptible to human error. If we look at the frequency of human performance errors - pilot errors - in commercial and in general aviation, we find that some 60 - 80 percent of these accidents have some human involvement. It is only reasonable to suspect that comparable proportions of human error exist in maintenance and inspection activities. We cannot reduce these errors simply by focusing singly on the person who is doing the work. We must consider in the broadest sense the total environment in which maintenance is done.

DAY-TO-DAY PROBLEMS IN AIR CARRIER MAINTENANCE AND INSPECTION OPERATIONS

*Robert T. Lutzinger
Manager of Aircraft Inspection
United Airlines*

In the typical inspection department of an airline the game plan, if you will, is accomplishing the Maintenance Plan. The preparation of that Maintenance Plan begins at the time of aircraft construction and the Maintenance Review Board. When the aircraft becomes operational, the airline has the responsibility to implement a Maintenance Plan of greater detail which spells out how they will systematically maintain that airplane in an airworthy fashion through regularly scheduled maintenance activities. This plan provides the timeframes within which we must perform certain functions of that aircraft maintenance program. The more comprehensive that program is, the more effective our Maintenance Plan will be and the better our opportunities to avoid incidents and irregularities.

At United Airlines, our typical Maintenance Plan includes the following maintenance opportunities:

Number 1 Checks - Activities requiring compliance for through flights with turn times of less than four and one-half hours.

Number 2 Checks - Activities we have identified as necessary to meet the overall maintenance program for aircraft that lay over four and one-half hours or more.

A Check - This occurs for the 737 aircraft, for example, every 200 hours. This is somewhat more extensive than a walk-around, but the aircraft is not opened up.

B Check - This occurs at about 550 hours and includes opening specific accessible areas of the aircraft. This generally is an overnight activity.

C Check - This occurs essentially on an annual basis or at about 3,000 hours. Access panels are opened and we go into the airplane extensively.

D Check - This occurs about every four years or at 16,000 to 18,000 hours. This check can last from 20 to 30 days. All access areas are opened and detailed work accomplished on the aircraft

structure and systems.

At United, the above activities are controlled and initiated with what we term Routine Paper Packages, each task related to a specified level of maintenance. In all, these constitute our game plan. I personally think the United game plan is a good one; however, the charge we have today is to discuss problem areas involved in carrying out the Maintenance Plan and the risks that might be associated with this plan. I will discuss these in terms characteristic to our airline operations.

Fleet Size. The different types of airplanes used by an airline can affect the maintenance program and the related behavior of maintenance inspectors. The ages of the airplanes and the types and various models of engines also can complicate the Maintenance Plan. The more complex the fleet, the more problems one may have with maintaining a qualified and experienced staff of inspectors.

In dealing with a complex fleet, it is particularly important that the routine maintenance package be as effective as possible so that the inspection function does not become a work generator but is a quality verifier. With the age of our aircraft growing daily, it is a quality verifier. With the age of our aircraft growing daily, it is imperative that our Maintenance Plan be continually adjusted so that the plan is the maintenance driver rather than a compilation of non-routine unscheduled maintenance events. As fleet size and complexity grow, the more likely it becomes that the non-routine activities affect the maintenance program. When such an imbalance occurs, it follows that greater risks become part of the inspection process.

Utilization. As the airline industry has grown, seeking ways to maximize the utility of its fleet has become a basic part of corporate strategy. Since maintenance causes aircraft to be on the ground, attention always must be given to minimizing maintenance down time. When United Airlines introduced its 747 fleet, for example, we started a phase check type program. Here, rather than having an aircraft be out of service for two, three, or even six days a year, the required maintenance elements were identified and phased in a planned visit so that we could accomplish these tasks on overnight stops when the airplane was not flying. This reduced the out-of-service time for the 747 fleet and literally saved us, at that time, one equivalent airplane.

Today, we have aircraft that have reached or gone beyond their "economic expected life." With these aircraft, we expect that structural inspections will find more discrepancies and that these aircraft must be dealt with using a somewhat different approach. This means that maintenance personnel must continually identify and make inputs into the Maintenance Plan strategy so that the plan may be adjusted to address these new requirements. If a phase check program allowing only for an eight hour turn is continually found to require 16 hours of work, we will soon have a major problem unless the Maintenance Plan is adjusted and we respond with changes. An ongoing plan review is most important for a maintenance program to be successful and effective.

Facilities and Work Environment. For the most part, the major facilities now used by the larger airlines for maintenance and inspection are quite good. While there may be some outdated facilities with significant environmental problems, I suspect they would be in a minority.

Every effort is made at our maintenance facility to insure a proper and safe work environment. Company representatives meet once a month with the Union Safety Committee and our Safety

Department personnel to consider issues concerning quality of the job and quality of the environment. An action list is reviewed which covers topics such as safety of equipment, heating and lighting problems, procedures for use in emergencies, job clothing, disposal of radioactive material, training for particular jobs, and any other matter considered important. As a result, our work environment is kept in as good condition as feasible, considering the work which must be done.

Personally, I have never found lighting conditions or heat/cold problems to be so severe at our location that quality of performance is adversely affected. We have always been able to get around these problems satisfactorily, whether through the use of local lighting, the use of warm clothing, or implementing some other solution. In addition, it is the expectation of an aircraft mechanic that he must, as part of his job, deal with some of these negative environmental elements. Our employees seem to adjust well, and under severe conditions they work to overcome these negative factors.

One problem with facilities for dealing with large jet aircraft concerns those structures necessary to effectively perform inspections on inaccessible parts of the airplane. At United, we have permanent structures around an airplane when it is in for a heavy maintenance check so that our inspectors have opportunities to inspect the aircraft. However, these structures are quite expensive. The cost of this equipment may represent a problem for some operators.

An environmental issue which is becoming an industry problem is dealing with paint stripping. There are many state and local regulations today concerning the use of these chemicals and the required training of people who use them. Because of this, some operators attempt to find better or different ways to accomplish this process.

Training and Experience. The rapid expansion of the airline industry over the past en years has resulted in a need for considerable larger numbers of qualified maintenance and inspection personnel. We have seen a real growth in our staffing requirements and found that the resources are simply not always there. In my opinion, it takes an inspector at an airline such as ours two years to become effective; six years to become efficient.

When an air carrier has a complex fleet, one having a variety of aircraft and engines requiring maintenance, the time required for an inspector to become fully complicate the issue, many of the skills of an inspector will be of the "use it or lost it" type. When dealing with eddy current inspections, magnetic particle inspections, ultrasonic inspections, or radiograph, the risk of performing an inspection improperly grows if the inspector is not performing that task with regularity - use it or lose it!

Skilled maintenance becomes even more important with areas of maintenance such as the Special Inspection Document (SID) Program which we will face more and more as our aircraft grow older. When an airplane reaches the special inspection threshold designated by cycles and hours, it becomes a candidate to have literally hundreds of additional inspections performed. The inspector assigned this task must apply his knowledge and expertise in making very precise technical judgments concerning the discrepancies he is looking for. This is a difficult assignment if the inspector has not done these particular inspections with some regularity. Prior to that special inspection, he might have been on a 747; the week before that on a 727; and the week before that on a 737. Maintenance of the necessary skills, some unique to the special inspection,

presents a problem for maintaining skill levels and assignments.

United Airlines recognizes the ongoing training requirement and this year will commit at least five percent of its inspection department for training on a regular basis. This means that some 15 to 17 inspectors will be in classroom training daily increasing their skill levels by engaging in special training experiences.

An aircraft inspector needs not only the formal classroom training, involving the operation of detailed parts and aircraft components, but also must acquire unique skills related to aircraft structures and systems. He must understand exactly that signal on the scope which indicates that a crack has been found, the meaning of those unusual noises that may occur on gear retraction, and the apparent stiffness of that aileron movement when the aircraft control wheel is turned. He must also recognize the significance of those blue water stains on the fuselage when he sees them. He must know that this may represent the possible corrosion and delamination of certain skin laps, even though the Maintenance Plan may not say, "Inspect fuselage for blue water stains." Only experience produces these sensitivities. In an expanding industry, the time required to obtain these experience levels is not available and represents a problem we must learn to deal with.

In order to assist in have desired performance levels maintained for our inspectors, United uses an error feedback process which we call the "C-3." We do not use these C-3 items for disciplinary purposes but instead attempt to employ them in a positive educational program for inspectors in which we point out the kinds of discrepancies being missed during aircraft checks. While this system is not always totally viewed as effective, it does assist in reviewing our process with our employees.

Unions. In a unionized operations, seniority plays a paramount role. By contract, most organized unions require assignments by seniority. This means that the older and more experienced employees often bid for the preferred shift, usually "Days." If the aircraft is down at night for inspection and maintenance, your experience at night is affected. In some instances, the night maintenance opportunity represents the most valuable maintenance time.

As they relate to company operations, unions see themselves as responsible more for "quality of life" issues for their members than for issues relating to quality or effectiveness of operation. Their concern centers on trying to insure a normal like for workers. i.e., proper vacations, appropriate economic reward, better shift work for senior vacations, appropriate economic reward, better shift work for senior workers, and similar matters. They do not give as great attention to workplace issues although, as I noted earlier, the Union Safety Committee does meet once a month with company representatives at United to discuss a variety of safety matters, some of which deal directly with the work-place environment.

The above topics represent some of the principal features of the maintenance and inspection process at United Airlines that I feel impact personnel performance. We recognize that we are in a growth industry; that we operate a mixed and complex fleet; and that our fleet is becoming older. Accordingly, we have increased our in-house training program and are beginning to employ new techniques such as video to inform and train our personnel. We are continually reviewing our Maintenance Plans to be certain that new problems are quickly incorporated into our routine tasks and inspections. We are in the process of developing specialized job fields as

we begin to use more sophisticated equipment to meet new maintenance challenges. Finally, we are expanding our networking capabilities with the rest of our industry, in part through our participation in industry-wide activities such as those of the Air Transport Association to enhance our skills and problem solving. The skills we are developing and the skills other airline are developing should be shared. We all have a stake in maintaining the highest quality of maintenance possible.

MAINTENANCE AND INSPECTION FROM THE MANUFACTURER'S POINT OF VIEW

*Robert L. Oldani
Manager, Maintenance and Ground Operations
Boeing Commercial Airplanes*

The process of establishing and conducting a proper maintenance program to support airline operations has a number of points which hold the possibility for human error. To illustrate this, I would like to review briefly the steps involved in developing an airline maintenance program. Then I will describe some innovations made by Boeing which we feel reduce both the cost of maintenance and the potential for error.

The maintenance process starts with the Maintenance Review Board (MRB). **Figure 1** shows that the Maintenance Review Board is composed of representatives of the manufacturer, the Federal Aviation Administration, and the airline that has just purchased the airplane. These representatives work together to develop a minimum maintenance program for that particular airplane. The MRB work lasts for a considerable period of time, in the order of eight to fourteen months, and draws on the expertise of a number of small working groups. These working groups consist of individuals with specific expertise in aircraft maintenance. They review the systems, the structures, the various other aspects of the airplane and based on their experience, determine what should be inspected, when it should be inspected, and how it should be inspected. The end result of this procedure is the issuance of a Maintenance Review Board Report.

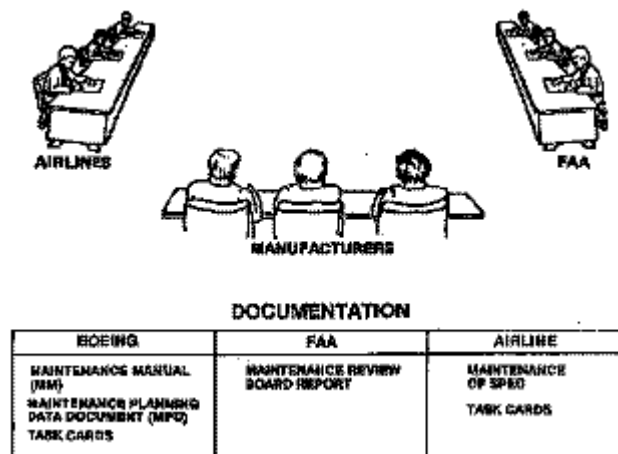

Figure 1 Airline scheduled maintenance program.

Three end products are produced by the manufacturer during the MRB, as shown in **Figure 1**. These are the maintenance tasks; the Maintenance Planning Document (MPD), which tells when and where to accomplish the task; and the task cards, which combine the information of the MPD and the maintenance manual.

The airline operator works from the Maintenance Planning Data document and the maintenance manual to develop their own Maintenance Operations Specifications. This becomes their official maintenance program when approved by the FAA. In addition, the airline also develops its own task cards.

The common area of task card development by the manufacturer and by the airline was considered at Boeing to be part of the MRB in which human error could be involved. Therefore, we developed what we call an Automated Customized Task Card.

Under the old task card system, used until the introduction of the 757/767 aircraft, the task cards told a maintenance man what to do and when to do it. Then he had to go to the maintenance manual to find how to do it. **Figure 2** illustrates the operation of the old task card system. Information from the task cards and the maintenance manual is fed to an airline task card writer who prepares task cards for the particular airplane. These customized task cards then go to the mechanic to direct his labor. However, mechanics require more information concerning the exact way in which to perform a task. Therefore, information from the maintenance manual is put into cassettes which then can be used with a microfilm or microfiche reader/printer. Mechanics then stand at the printer and wait to get their instructions as to how to do the job. Hopefully, they get the right printout to match the task card. This is a part of the process in which errors can be made.

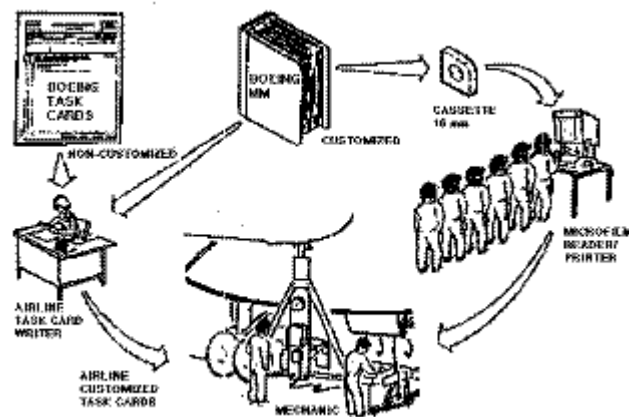

Figure 2 Old method using non-customized task cards.

To expedite the maintenance process and to reduce the possibility of error, Boeing improved on the old system with the development of the "Automated Customized Task Card" method, illustrated in **Figure 3**. This method eliminates the task card writer and the microfilmer reader/printer from the process entirely. Material from the maintenance manual is computerized and then accessed through use of what we call "hooks" to obtain specific items.

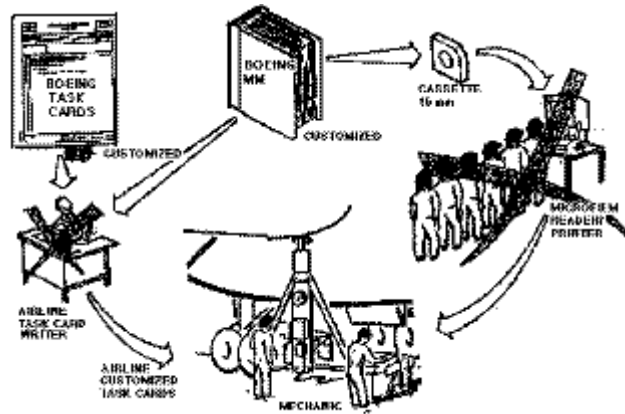

Figure 3 New method using Automated Customized Task Cards.

Under the new system, the maintenance manual is revised on a 60- to 90-day basis. The Customized Task Cards thus are revised on the same basis, which means that the mechanic always is dealing with up-to-date data. In addition, the new task cards can provide all of the needed illustrations.

Figure 4 presents a sample of an Automated Customized Task Card. This task card covers cleaning of a cooling pack/heat exchanger on a 767 aircraft. **Figure 5** shows the illustrations accompanying this particular task card. With these new task cards, the mechanic now has everything he needs to properly conduct that particular task. He has the equipment, the material, the procedure, and all of the illustrations, all reflecting the latest changes. From a human factors point of view, we feel this is a considerably better maintenance support program.

STATION		UAL BOEING 767 TASK CARD			BOEING CARD NO 21-017-01	
DATE					AIRLINE CARD NO	
SKILL	WORK AREA	RELATED TASK	INTERVAL	PHASE	REVISION	
AIRPL	ECS BAY		2C	12629	# FEB 10/88	
TASK	TITLE		STRUCTURAL ILLUSTRATION REFERENCE		APPLICABILITY	
CLEAN	COOLING PACK HEAT EXCHANGE				AEROPLANE ENGINE	
ZONES		193 NL 194 LR		ACCESS PANELS		
135 136						
STEP	CLEAN PRIMARY & SECONDARY COOLING PACK HEAT EXCHANGERS (IF HEAT EXCHANGERS ARE NOT CHECKED FOR EFFICIENCY)					21-51-02-7A
	<ol style="list-style-type: none"> 1. <u>Referenced Procedures</u> <ol style="list-style-type: none"> A. 06-41-00/201, Fuselage Access Doors and Panels 2. <u>Equipment</u> <ol style="list-style-type: none"> A. Spray Nozzle, 9702A-10-TM-TC-9502, Spray Systems Co. Wheaton, IL B. Air compressor (80 to 100 psi) commercially available C. Spray gun (compatible with air compressor or steam cleaner) commercially available D. Steam Cleaner (80-200 psi) commercially available 3. <u>Materials</u> <ol style="list-style-type: none"> A. SOLYENT, P-D-680, DRY CLEANING (Ref 20-30-02) 4. <u>Clean Heat Exchangers (Fig. 701)</u> <ol style="list-style-type: none"> A. Place pack control selector on Pilot's Overhead P5 Panel in OFF. Place DO-NOT-OPERATE identifier on selector B. Open appropriate ECS access door 193NL or 194LR and locate heat exchangers (Ref. 06-41-00). C Remove access doors in plenum, ram air inlet duct, and between the heat exchangers. D Clean the primary and secondary heat exchangers. 					
EFFECTIVITY	ALL		CLEAN	COOLING PACK HEAT EXCHANGERS		
			21-51-02-7A	21-017-01	PAGE 1 OF 3 FEB 10/88	

Figure 4 Sample Automated Customized Task Card.

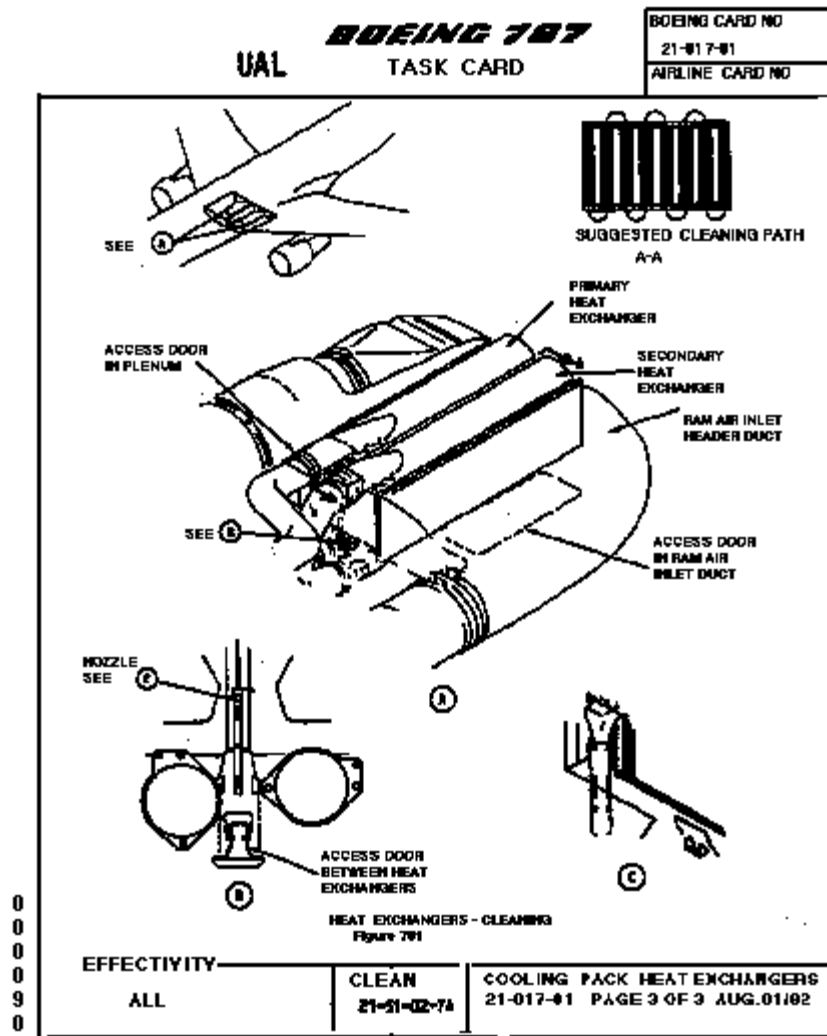

Figure 5 Illustrations accompanying Automated Customized Task Card.

There are a number of benefits with use of the new customized task card system. It reduces the number of airline man-hours expended in writing and revising job cards; it eliminates a mechanic's need to refer to microfilm; it eliminates lines of mechanics waiting at the microfilm reader; and it eliminates errors due to manually transferring and retyping the manufacturer's data. A final benefit is that each airline receives that latest information from the maintenance manual. This eliminates guesswork in identifying applicable maintenance manuals can be complicated, with their particular accession and numbering systems. With the automated system, airlines can easily identify revisions in the maintenance manual affecting their scheduled maintenance.

One airline operator who accepted our system and evaluated it over a one-year period estimated that they saved over \$1 million. This was based on eliminating the task writing, eliminating the problem of mechanics waiting to look at microfilm, and generally expediting the labors. Several other airlines do not actually use our task cards to direct maintenance but, rather, use them to determine when we have revised the maintenance manual. Rather than going through the total revision, they just go to the task cards to look for a revised card. They then know the

maintenance manual has been changed for that process. Finally, we provide this information on magnetic tapes to some airlines who prefer to develop their own computerized task card systems.

Another area of concern to the airlines is Service Bulletins. These are documents prepared by engineers working at desks in the manufacturer's facility. They can be rather complex, and may use language meaningful only at the engineering level. In order to make Service Bulletins more readable, Boeing is attempting to improve their content by using what we call "**simplified English.**" This is English which we feel can be readily understood by the average mechanic. Again, the purpose is to reduce errors of interpretation.

A final recommendation of mine is that we continue to use whatever means we have - such as this meeting - to review our maintenance problems and to spread work throughout the industry concerning new or improved ways of doing things. If we have a safety situation and have options to resolve the problem, everyone should know about it. We are talking about the total airline fleet.

HUMAN PERFORMANCE IN AIRCRAFT MAINTENANCE: THE ROLE OF AIRCRAFT DESIGN

*Anthony E. Majoros, Ph. D.
Engineer Scientist
Douglas Aircraft Company*

This presentation describes work being done by the Douglas Aircraft Company concerning human factors in maintainability and design for ease of maintenance. Specific topics are (1) human factors aspects of supplemental inspections, (2) maintainer workload, and (3) maintainer reliability.

Supplemental Inspections

A fundamental truth in design is that provision for supplemental inspections is seldom built in as part of the initial aircraft design. With an aging aircraft fleet, however, supplemental inspections have become and will continue to be a way of life. For the inspector dealing with an aircraft with no design provision for supplemental inspection, definition of the inspection concept may be unnecessarily complex and access to inspection areas may be difficult.

We believe that it is possible to aid the inspector by defining inspection concepts. One way to do this is through use of a computer-generated anthropomorphic model. **Figure 1** shows that manner in which we used such a model to demonstrate two possibilities for inspecting the inner frames of a DC-3 vertical stabilizer. The model is based on anthropometric dimensions taken from Military Standard 1472 and the Navy Crew Assessment of Reach (CAR-4) algorithms.

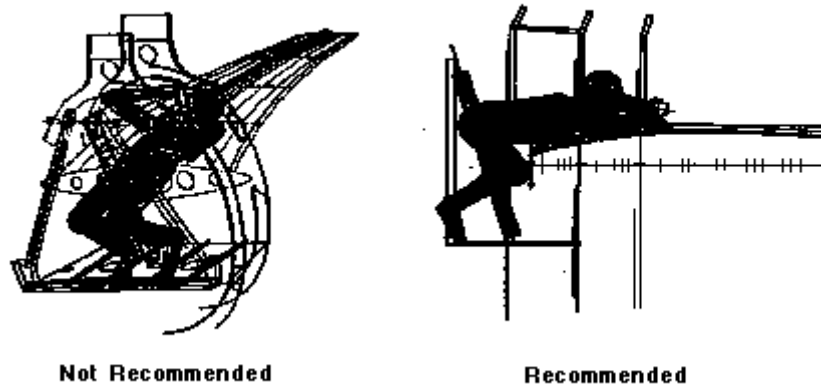

Figure 1 Computer simulated DC-3 vertical stabilizer inspection.

We would not recommend that the inspector lie with his back on the horizontal stabilizer as shown on the left in **Figure 1**. We would recommend instead that the inspector lie with his stomach on the horizontal stabilizer and see the overhead view with a mirror. We compared our simulation of this task with actual attempts to perform the inspection on a DC-3. By personal experience, I can tell you there is good reason not to recommend the procedure shown on the left. It is difficult to get into and out of the position, it is painful, and very little can be seen. Inferences about the difficulties of this inspection made possible with computer simulation compared very well with the actual experience.

In one design evaluation, we considered a maintainer attempting removal of a flight control module from the upper aspect of a vertical stabilizer. The analysis showed that the pull of gravity on that component, weighing about 44 pounds, presented sufficient risk that the maintainer would incorrectly remove the package and so damage the delicate ribs within the vertical stabilizer, that a recommendation was made to mount the flight control module on the outside of the rear spar of the vertical stabilizer and not on the inside. This illustrates consideration of several variables during static simulation of maintainers. One is weight-lifting and carrying limitations, another is maintainer comfort (or pain), another concerns postural difficulties, and a final one is time required to hold posture and to generate force in certain postures. All of this information bears on the ability of the maintainer to perform the operation efficiently and accurately.

There is an emerging belief within the Douglas Aircraft Company that computer-assisted design (CAD) environments represent the way all design will be done in the future. There will be less paper and more electronic models. Within this environment, sophisticated anthropometric models can be used to predict the performance of people in any position within aircraft structures. Ultimately, these anthropomorphic models will show real-time motion characteristics and will have vision and strength capabilities as well.

Maintainer Workload

In aircraft flight operations, excessive levels of workload are considered to be associated with increased error likelihood. We make the same assumption with maintainer workload. We believe that as workload increases beyond certain acceptable levels, the chances of error being made by the maintainer are increased.

We have performed some preliminary work in an attempt to locate aircraft systems during design that we believe are likely sources of unacceptable levels of maintenance error. In **Figure 2**, ten selected aircraft systems are plotted for maintainability, reliability, and ratio of difficult to easy tasks within the system. Maintainability, specifically mean man-hours to repair (MTTR) is plotted on the left-right axis; reliability, specifically mean time between corrective maintenance actions (MTBM(C)) is plotted on the front-back axis; and the ratio of difficult to easy tasks, specifically the skew of the distribution of task times within a system, is plotted on the up-down axis.

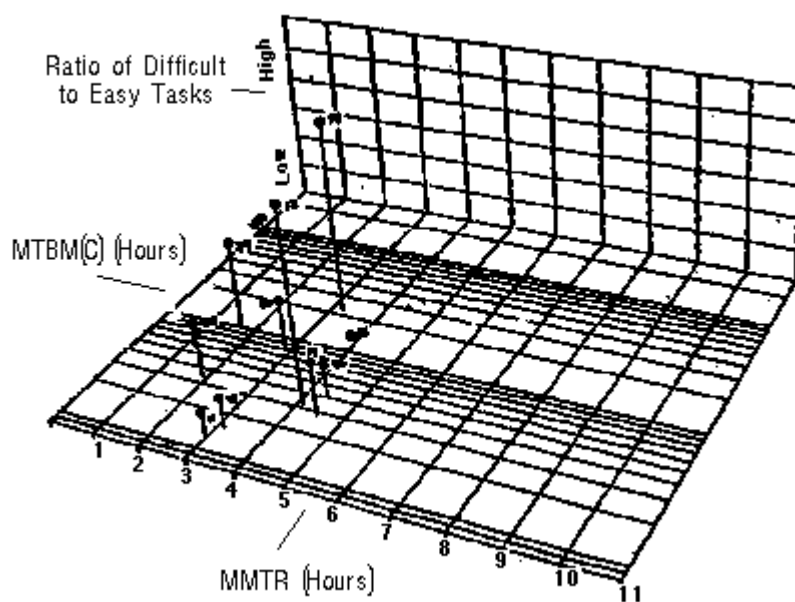

Figure 2 Three-ax graph used to identify systems loaded with tasks requiring many time-consuming steps.

Task times for aircraft systems are generally positively skewed, and the greater the ratio of time-consuming (difficult, with many steps) to fast (easy, with few steps) tasks in the system, the greater the degree of skew. We made the assumption that systems whose tasks times are more skewed offer relatively more opportunities for maintenance error. In the figure, systems with longer stems are more positively skewed. With a graph of three variables, we can determine an aircraft system's availability by plotting the location of the bottom of its stem on the "floor" of the graph in terms of reliability and maintainability, and we can check the system's potential for

error by noting the length of the stem.

In **Figure 2**, flight control (System 14) and independent position determining (System 72) contribute nearly identical burdens to aircraft availability, yet the position determining system offers relatively more opportunities for error. We would conclude that position determining - in the design configuration under study - is a better candidate for human factors attention to maintenance error reduction than flight control.

Note that error rates are not used in the analysis in **Figure 2**. The three axis graph is used to locate aircraft systems that have a high proportion of time consuming tasks on the assumption that those systems contain more chances for error.

In our review of workload parameters relative to aircraft maintenance, we identified three aspects worthy of in-depth consideration. These are (1) infrequency or novelty of a task or defect, (2) the cognitive complexity of the task or the mental demands the tasks imposes, and (3) the physical and physiological demands of the task. Each of these is reviewed next.

1. Infrequency or Novelty of Task/Defect. One of the rules of inspection and quality assurance is that rare defects are difficult to detect. As you increase the percentage of defects present in a sample, the likelihood of catching a given defect increases.

One way to aid an inspector in dealing with rare events is with procedural checklists that guide the user. To study the potential of checklists to guide the search for uncommon errors, we created three types of checklists for use in an experiment. The experiment required subjects to search for characteristics of a design that could be considered "errors" from the standpoint of maintainability, but the same logic could apply to an inspector checking system for integrity. One checklist contained irrelevant items, a second contained conventional USAF maintainability checklist items that were not specific to any particular aircraft system, and a third contained items written at Douglas Aircraft that were specialized for the system under examination by the subjects. As shown in **Figure 3**, we found that more errors were determined with the specialized checklist.

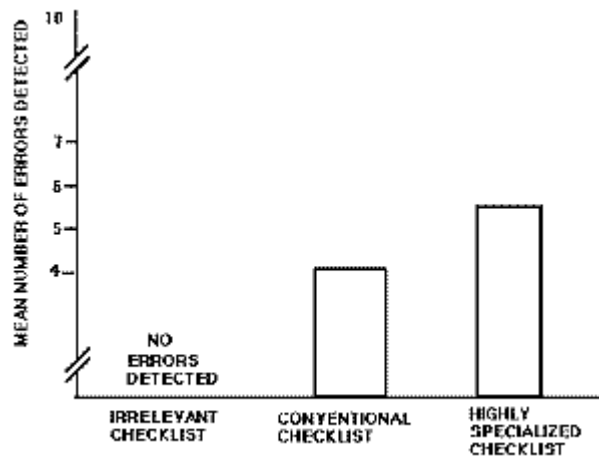

Figure 3 Comparison of conventional vs. improved checklists.

2. Cognitive Complexity of Tasks. Aircraft obviously are complicated systems. Nicholas Bond, in a recent chapter in the Handbook of Human Factors, makes the observation that, in his opinion, no single person understands everything about certain aircraft systems. He uses the F-18 flight control system as an example, and states that no one is alive who understands it all. Many systems within civil transport aircraft are similar. They are highly complicated and few individuals understand them completely.

One problem with increasingly complicated systems is that the representation, or the mental model of what a person should look for, becomes difficult for a maintainer to hold for a long time. Methods that enhance the representation for that person can do nothing but help. A few years ago, in an attempt to improve this situation an "Advanced Maintenance Information Packet" was developed. In this, maintenance tasks are numbered in a step-by-step sequence, with accompanying graphic presentations. Even the position of the hand relative to where the maintainer would be standing or sitting is shown. Cautions and warnings are put before the action; tools and special equipment are identified before the action begins.

The advanced maintenance information concept was tested with novice mechanics and for what were termed major errors. This would be an incorrect removal and replacing the wrong part. In this test, use of the advanced maintenance information system produced a 55 percent reduction in errors. For minor errors, such as incorrect torque on bolts, there was a 79 percent reduction in error.

One concern about the advanced maintenance information concept was that the many different and necessary illustrations made it prohibitively expensive. This is not the case today. Computer generated graphics, much less expensive to produce, can be used to illustrate maintenance actions.

Another aid in overcoming the cognitive complexity faced by maintainers is through use of expert systems during the design stage. Designs can be more or less maintainable for a number of reasons. If these reasons are incorporated into an expert system, the designer will be able to rapidly evaluate a new design for its maintenance characteristics. The designer should be able to ask the expert system questions such as: "Given this task, a change of a filter requiring two seals in this location of the aircraft, how long will it take to make the change if the filter is in this locations?" This is basic maintainability information and it can be very valuable during the design stage.

3. Physical and Physiological Demands. Another aspect of workload concerns physical and physiological demands placed on the maintainer. **Table 1** presents results of a small survey done with operators of Douglas products. As can be seen, weight and access complaints are most frequent among civil aircraft maintainers. Visual lighting problems were next, followed by difficulties with connectors, seals and component installation.

TABLE 1
 MAINTENANCE PROBLEM AREAS NOTED IN
 SMALL SURVEY OF OPERATORS OF DOUGLAS AIRCRAFT

Access and weight	28%
Visual, lighting	18%
Connectors	16%
Seals	7%
Installation	7%
Others	24%

The Douglas survey was small and informal. More data than we obtained are required. Many questions concerning difficulty of maintenance were not asked in this survey. Such information is needed for designers to understand how to develop a product that maintainers can work on most efficiently.

Designers should be able to reduce physical and physiological demands by attention to placement of components when the structure permits some variation of placement. **Figure 4** presents one approach to solve installation questions during design. The figure is a working envelope for removal of a slat lock valve. Spatial coordinates for this envelope were obtained by videotaping the removal of the valve from a wing mockup. Cameras were set above and to the side of the valve location in the mockup.

Working envelope for slat lock valve removal
 fire ex tubing does not obstruct removal.

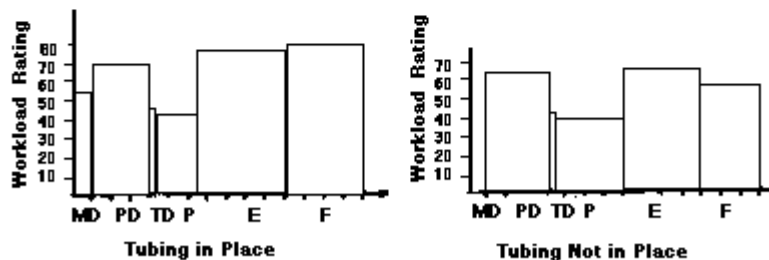
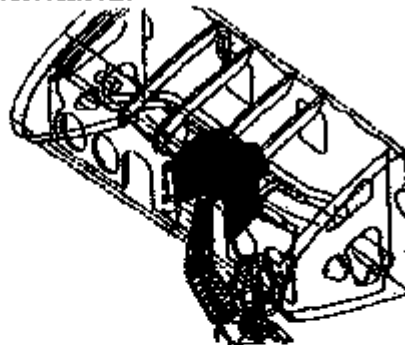

Figure 4 Workload for slat lock valve removal compared with and without fire ex tubing in

place.

The working envelope shows the maximum excursions of hands, tools, fasteners, and the valve itself during removal. Two trials were videotaped: removal without any obstruction - which required 12 1/2 minutes - and removal when fire extinguisher tubing obstructed access - which required 16 minutes. We can conclude that if the tubing were routed to avoid obstruction, valve removal would require about 25 percent less time. This study is a first step toward defining required working envelopes for components during design. If equipment is arranged in the aircraft with adequate working envelopes, maintenance workload can be reduced.

We developed workload measures on the above task using the NASA Task Load Index to measure operational workload. This system rates mental demands (MD), physical demands (PD), temporal demand (TD), performance (P), effort (E), and frustration (F). Here we see that effort and frustration are increased by having a design that includes the fire extube below the slot valve. This offers us a chance to understand some sources of error that could head to damage during the performance of the task.

Maintainer Reliability

There is growing interest in maintenance reliability. Reliability concerns errors, departures from procedures, time to complete tasks, and damage or induced maintenance. The goal at the design stage is to aid the mechanic by designing to reduce error likelihood.

Many aspects of maintenance affect error potential. **Figure 5** is an example of labeling that led to error. Labels and placards are part of the world that guides inspectors and maintainers to do their job. In this case, one can connect P26 to either J5 or J6 of the adapter. This test is for an aerial refueling boom and in one case (J5) you test the elevator actuator. In the other (J6), you test the aileron actuator on the flying boom. However, mechanics interpreted the labeling to mean "take your choice," but that is not what it meant. This led to many test errors. The role of human factors here is to identify those design variables that lead to error and develop procedures to control them.

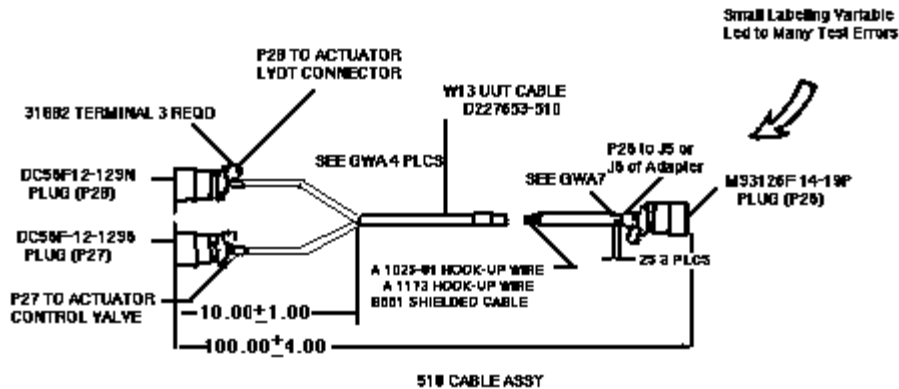

Figure 5 Test set lead and labels leading to maintenance error.

From a manufacturer's standpoint, a number of approaches appear worthwhile in a program to reduce maintenance and inspection error. Briefly, these include:

1. Manufacturers need to team with aircraft operators in the collection of necessary data. What errors are being made; what are the most frequent types; and, perhaps with workload measures, what are the components of error?
2. Inspection concepts must be defined to facilitate inspection as much as possible and ensure best performance.
3. Checklists must be improved.
4. Maintenance aids should be developed for with knowledge representation both in paper form and in expert system form.
5. Aircraft systems should be designed for ease of access.
6. Modelling should be employed to aid in the development of maintenance procedures. Anthropomorphic models are becoming so sophisticated that maintenance procedures could be modeled before an aircraft is built.
7. A research center, or at least a coordinated research effort, is needed where problems can be studied in depth and where concepts can be tested to assess design configurations and their contribution to error. There is no place where regulatory agencies, operators, and manufacturers can team together to examine concepts and to examine the role of environmental variables that are often assumed to play a part in maintenance effectiveness.

Finally, I would offer one comment on use of models. Models hold the illusion of solution, but they are not the solution. They aid in interpretation and/or application of human engineering judgment. They do not replace human engineering judgment.

OPERATIONS

*Robert Doll
Vice President of Technical Services
United Airlines*

An important avenue for the coordination of maintenance improvement and the exchange of related information within the airline industry is through the Engineering and Maintenance Council (EMC) of the Air Transport Association. I am the representative of United Airlines to the EMC. My remarks today represent the activities of the EMC and the industry in general rather than a specific United Airlines position.

The ATA Engineering and Maintenance Council recently formed with the FAA and other industry representatives, a steering committee to consider a number of issues raised during the FAA conference on Aging Aircraft held on June 1-3, 1988 in Crystal City, Virginia. The first item on the agenda of the steering committee is to examine the technical problems that underlie the industry's and the public's concern about the manufacture of aging aircraft. The technical issues are structural integrity and corrosion. At this time, there is no industrial standard for corrosion. At this time, there is no industrial standard for corrosion control. Fleet specific task groups have been formed to consider the integration of corrosion control programs with the existing structural inspection program for individual fleet types.

The second major item on the steering committee's agenda is human factors, which, of course, is the topic of this meeting. We anticipate working closely with the FAA human factors program to ensure that our activities are mutually supportive.

Within the scope of human factors, the issues we have selected as important closely parallel those mentioned earlier today. The first issue is the work environment, and here we are concerned both with the work environment as designed at the time of manufacture and the work environment provided by the operator. The second issue is of design and system maintainability. This is a problem with long range solutions but one which, as we have heard, manufacturers such as Douglas Aircraft are now addressing vigorously. The third issue concerns the preparation and training of an individual to work in a maintenance facility, whether he works as an inspector or as a mechanic. Here we must recognize that we are not talking about clear-cut job entities. A lot of the inspection chores are actually carried out by A&P mechanics.

Next we come to the matter of qualifications, and here we are talking about the basic A&P license. There are questions as to whether we should go to more certification and licensing at higher levels. While there might be advantages, one very practical problem with increased licensing is that it generally leads to a more complex pay structure which, in turn, places a heavier administrative burden on the airlines.

A final issue within our human factors agenda concerns job instruction. How do we instruct an inspector or mechanic to do a specific job? What kind of language do we use? This issue, of course, goes well beyond our internal communications within an airline. It includes the manner in which a Service Bulletin prepared by the manufacturer, or an A.S. prepared by the FAA is written. The A.D., for example, is prepared by an engineer, reviewed by an attorney, sprinkled with "Washingtonese," and then delivered to the airline operator. We have a reasonable chance

to interpret it properly in San Francisco, but consider the plight of the maintenance supervisor in Hamburg or Paris, translating to his language.

The third area of inquiry for the steering committee is new technology. One part of this with human factors implications is the use of expert systems. One means of circumventing to some extent the requirement for experience and training is to have an expert system, a computerized means of providing the needed expertise rather than depending on an experienced mechanic. Expert systems, if incorporated properly, can play a very useful role.

New technology also encompasses aircraft systems. Use of composite materials presents a new set of demands for inspection. Such materials are not compatible with some of the existing inspection procedures, one example being the use of eddy currents to explore possible cracks within composited structures. We have to understand these new materials from the point of view of maintainability, repairability, and associated human factors problems.

The last agenda item for the steering committee, and perhaps the most important item, is that of communications. How do we share information? How do we communicate problems? In the maintenance base at United Airlines, we have about 12,000 employees, each one of whom is involved in many information transactions in a single day. How do we manage this information exchange so it best supports our maintenance objectives?

At United, we have made attempts to better manage this information flow and to better understand its dynamics. For example, many years ago we began a fault isolation program to code maintenance problems in order to classify them in a way that we could then run computer analyses.

In a recent "classic" incident, we had an airplane problem which the crew code as "Left brakes binding. Airplane pulls to left on landing." So we went in and replaced the brakes on the left side. The airplane flew again and we got the same report from the crew: "Left brakes binding, Airplane pulls to left." This time we went in more deeply, changing parts in the anti-skid system and some other components. Well, guess what the problem turned out to be? The right brakes didn't work.

Here we have simple maintenance problem which, through neglect of human factors considerations, became a more complex problem. If someone had simply said "The airplane pulls to the left," we probably would have checked both brakes. But someone got one more level into trouble-shooting than was required and the system led us down the wrong path. The issue here, of course, is one of information exchange. How can we insure that the data we receive is translated to information appropriate to our needs in maintenance?

I happen to believe that there is a fairly simple dictionary that could be put together for use in fault isolation that would be easier to learn than a system based on significant number codes. This approach would be put together for use in fault isolation that would be easier to learn than a system based on significant number codes. This approach would be more appropriate for human understanding. Problems would be reported in standard terms commonly used. For example, the report "Airplane pulls left" uses words well known to all. Certainly, humans relate to this better than to a problem described as "001--3002." Then, by use of a standard dictionary of terms, word-processing techniques could be employed with the key words, yielding a higher likelihood

of an accurate diagnosis.

Another issue that falls under the scope of communications is the exchange of information among the different players in the industry. There is a need for an improved data base of maintenance information to be shared throughout our industry. As good as some of us think our networking is, I did not know about. The same is probably true for work at Boeing. Ours is a very complex industry. We need an efficient data base that will keep all of us abreast of advances.

Maintenance and inspection programs are built on the premise of commonality - that we have common fleets. In fact, this is not true. United Airlines has nominally 400 airplanes. No two of them are alike. Some are more alike than others, but every one of our maintenance systems is based on the assumption that they are common and that we are going to find the differences. This can lead to serious consequences when an error is made.

If I assume all aircraft are different and then look for the commonality, I don't have the same problem if I miss a commonality as I do if I assume they are common and then miss a difference. In terms of human factors, we are creating an error prone process by starting with a bad assumption.

Another problem in our industry is that in the past our audits, including those conducted by the FAA and those conducted internally by an airline, accept a 95 percent performance level or above as okay. By comparison, segments of the manufacturing industry decided some time ago that anything less than 100 percent quality as a target only leads to problems. Why should one ignore five mistakes in 100 and consider that good performance?

In maintenance operations, we must come to realize that we are the ultimate example of a zero-defects industry. Statistics describing the low incidence of mechanically related accidents should not provide any measure of comfort. When you look at an accident classified as "pilot error," you frequently find a mechanical problem somewhere along the line of causal events leading to the accident. The L-1011 accident which occurred in the Florida everglades many years ago is an excellent example. In this case, crew members were distracted from the flight regime by the failure of a landing gear light to illuminate when the nose gear was lowered. Trying to evaluate the problem took the full attention of the flight deck crew, during which time the low altitude alarm system was accidentally disengaged and the aircraft gradually descended into the swamp.

We obviously cannot accept any level of defect in maintenance. It is just not good business. Every airline operator and every manufacturer has a stake in 100 percent safety. Every commercial carrier must have total dedication to safety. I want every airline to spend the same money on maintenance that I spend and to be as safe as I'm safe.

Somehow this part of the industry (the least common denominator) must be brought up to the same level of commitment as the rest of the operators. This is one issue being examined now by the industry steering committee. The question is "What do we do as an industry to ensure that we have 100 percent quality performance on an industry-wide basis?"

To meet a standard of 100 percent quality performance, we must design our systems so that we do not build errors into the system. In particular, we must build systems that allow aircraft

inspectors and aircraft mechanics to do their jobs efficiently and to make their full contribution to aviation safety. The air carrier industry, both as individual operators and through industry-wide activities such as the aging aircraft program, is searching for means to manage human error during aircraft maintenance and inspection and to make ours truly a zero-defects industry.

INSPECTION AND MAINTENANCE ISSUES IN COMMUTER AIR CARRIER OPERATIONS

*Norman S. Grubb
Vice President, Maintenance and Engineering
Henson Airlines*

Introduction

The commuter air carrier industry of this country and the world has experienced a very volatile and rapid growth over recent years from the "Mom and Pop" entrepreneur operations of ten years ago with a few aircraft to the large corporate regional air carriers of today. Large fleets of sophisticated and new generation aircraft cover route structures over large segments of the United States. This explosive growth has brought with it a unique challenge in the human aspects needed to support the sophistication of the industry. (NOTE: The following remarks represent input from four commuter air carriers).

Thesis

It is our contention that the human elements of the equation have lagged behind and not kept pace with the technologies of today's new generation aircraft, coupled with the market demands of the commuter industry. I say this because of the many human factors issues that we see in today's workplace. These factors span the industry from the manufacturer of the equipment, to the regulatory agencies, to the mechanic on the job.

Issues

Let us examine these issues and discuss their impact on the production of a safe and reliable product.

1. Sophistication of the new generation commuter aircraft vs. the "old school."
2. Training.
3. Manufacturer support.
4. Frictions between AP Mechanics and Quality Control Inspectors.
5. Clock-card employee turnover and experience level.
6. Management turnover and competency as it affects the man on the job.
7. Aircraft utilization vs. aircraft maintenance ground time.
8. Fatigue.

9. Morale/job satisfaction.
10. Drug/alcohol dependency.

Sophistication of New Generation Commuter Aircraft vs. the Old School

The technology of the new generation aircraft with the more extensive use of microprocessors, integrated circuits, and advanced avionics has surpassed the know-how of the majority of AP Mechanics and Inspectors.

The AP School curriculum has not kept pace with advances in the industry. The "dope and fabric" days are over and yet this subject, as well as "woodworking," is still taught in AP Schools. Needless to say, the A&P curriculum is totally inadequate and a drastic overhaul of what we are teaching in the AP Schools is badly needed to prepare mechanics for the "high tech" commuter aircraft of today and tomorrow.

Some of the more technically-trained and capable employees are the avionics technicians who have gone through an FAA-approved avionics school. These people are virtually ignored in the traditional FAA organizational structure. For example, an Avionics Manager cannot be yet an old-timer can be Director of Maintenance strictly with an AP license, and understand very little about today's high tech aircraft. An avionics technician can graduate from an FAA avionics school, but there is no license that allows the technician to work on the aircraft or sign-off his own work. An avionics technician must obtain a repairman's certificate in radio and instrument repair before he can sign-off his work. An SP mechanic can be taken from the ranks and trained in-house in a few months and be doing work and signing off work that the trained avionics technician cannot do until he gets an airman's certificate requiring as much time as the FAA Administrator deems necessary. This can be up to 18 months of practical experience in the specific job category, and then this certificate is not transferable to another employer (FAR 65.101). Again, this is a deficiency in today's school system for qualifying our technicians.

Training

In view of the inadequate training of today's AP in school, new hires are not ready for systems training on the commuter aircraft. After an initial indoctrination program, the new hire is put to work on the floor with an experienced mechanic for aircraft familiarization a month or two before systems training can be meaningful and absorbed by the mechanic.

Manufacturer Support

The manufacturers of today's new generation aircraft have rushed the product to market before full technical support is developed. Maintenance manuals leave much to be desired in terms of wear limits, damage limits, repair schemes and adequate or accurate wiring diagrams. As situations occur, the operators find themselves going back to the manufacturer frequently for repair limits, repair limits, repair schemes and other relief, and this information is forthcoming after the information is developed by the engineers and approved by the DER/DAR (Designated

Engineering Representative/Designated Airworthiness Representative). In the meantime, an aircraft is AOG ("Aircraft on Ground"). The operator is caught between not having adequate manual information for the aircraft and not being able to make subjective judgments in violation of the FAR's as interpreted by the Federal Aviation Administration. The industry needs some latitude in making judgment calls by mature and experienced maintenance personnel.

Friction Between AP Mechanics and Quality Control Inspectors

In my opinion, this issue has the most effect on people in the maintenance and inspection category in terms of mental and physical strains of the job. Maintenance people have the pressure of getting the aircraft to the gate on time, and inspectors have the pressure of making certain the aircraft is airworthy before it leaves maintenance for revenue service. This raises many questions between the two groups as to what is airworthy and what isn't, and on what basis is the determination made? This situation causes an adversarial relationship between the inspectors and the mechanics and supervisors. Maintenance people think the inspectors do not feel responsible for getting the aircraft out on time and that they continue to write-up items and are "nitpicking." Maintenance is dedicated to putting out a safe aircraft, but on many occasions, the inspectors do not consider the aircraft airworthy by the strict definition or interpretation of the FAR's. The more experienced maintenance people feel they should be able to make subjective judgments and that the less experienced inspectors are looking for objective judgments or decisions only - in other words, they want to go strictly "by the book." I'm sure this is an old story to all of you; nevertheless, this causes mental and physical strain on both the maintenance group and the inspectors.

In the Shop atmosphere however, where there is not a gate time to meet, an adversarial relationship does not exist between the mechanics, supervisor and inspectors. In fact, maintenance welcomes the inspection group in the Shop atmosphere and sees them as a help rather than a hindrance. It appears the pressure of the gate time makes the difference.

Clock-Card Employee Turnover and Experience Level

The commuter industry has experienced an extremely high turnover due to the major air carriers' expansion and need for mechanics and inspectors. Since the commuters then have to fill the ranks from AP School, the military, or from Fixed-Base Operators (FBO's), there is a large percentage of inexperienced mechanics, particularly on a type aircraft. This makes both the inspectors' job and the supervisors' job more difficult, and it does result in less efficient operations, since not as much work is accomplished and more mistakes are made that must be corrected.

Management Turnover and Competence As It Affects the Man on the Job

With the rapid expansion of the industry, there has been an increasing demand for experienced and competent management to fill the many positions that have become available. As a result, there has been considerable movement of managers from operator to operator and many

managers in their present positions have not had longevity in that position with the particular company. The workforce sees instability in management and in the policies and procedures that ensue. Also, a lot of the administrative work falls on the lower-level supervisors as the learning process of the new manager takes place. This allows less time for the supervisor to spend with the mechanics or inspectors on the job.

The second part of the increased need for management is that a number of young people have been promoted from within to authoritative positions and these people are relatively inexperienced in management. They are good people and have great potential, but many times they make management decisions based on their ego rather than on sound managerial judgment. This tendency of a new manager to show his authority rather than consult with the more experienced often results in poor decisions, particularly in the handling of personnel.

Thus, in a rapidly-expanding industry, whether you promote from within or hire from outside, there is a maturing period for the manager which has a direct effect on the workforce.

Aircraft Utilization vs. Aircraft Maintenance Ground Time

This is a never-ending battle and maintenance usually loses as a result of the marketplace and cost-effectiveness pressures that prevail in most commuter operations. To meet your competition, higher aircraft utilization is necessary and more maintenance has to be squeezed into fewer hours of ground time at the maintenance base. It is not unusual for an RON aircraft to arrive at midnight with a run-up time of 5:00 a.m. to meet a departure at 6:00 a.m. This time constraint does put pressure on the maintenance and inspection groups, as well as causes friction between these two groups, which I have addressed as a separate issue.

Fatigue

The high turnover in the mechanics' ranks due to mechanics moving up to major carriers results in the hiring of young mechanics who are often just out of school and starting families. These mechanics, working at starting wages, find it difficult to make ends meet and often require second jobs. In "burning the candle at both ends," these mechanics become tired and are obviously less effective and more prone to making mistakes.

At other times, there are situations when the hiring rate has not kept up with the turnover and there is a shortage of mechanics. This leads to overtime and longer than normal hours and, again, contributes to the fatigue of an employee and the associated vulnerability.

The night schedule required for RON maintenance of airline aircraft is a factor in fatigue also, particularly for newer employees who are not used to the night routine. The mechanic has to do his business during the day and often goes to work tired as a result. When a mechanic is tired, that is when he takes shortcuts in doing his job.

Morale/Job Satisfaction

Basically people want to feel appreciated and want to feel good about themselves and the job they are doing. When a mechanic doesn't like what he's doing, or doesn't feel good about his job,

his work suffers and this is not necessarily a conscious effort on the employee's part. When the mechanic does not have his heart in the work, that is when details will be overlooked and oversights will occur. Good morale of the workforce can make the difference, and many things, of course, go into making good moral, but, in my opinion, some of the more important are: (1) letting the troops know when a job has been well done; (2) maintaining a clean, well-kept and good-appearing workplace or environment; (3) having all the necessary tools and equipment and having them in good repair; and (4) communicate, communicate, communicate!

Drug/Alcohol Dependency

What can I say that hasn't already been said about drugs and alcohol problems in our society today? However, in our industry, this problem must have particular emphasis as the lives of so many people are at stake. I am proud to say that Henson Airlines has mandatory drug-testing in the hiring process and drug-testing of individuals involved in any incident or accident. However, the entire industry needs mandatory drug-testing of the workforce. This should be a top priority.

I can honestly say that I have not personally seen any evidence of drugs or alcohol use or abuse in our workforce. However, we must remain alert and always be on the lookout for the problem. Our experience has been that less than one percent of mechanic applicants have been turned down for employment as a result of positive drug-testing results.

Thank you.

HUMAN FACTORS IN AIRCRAFT MAINTENANCE AND INSPECTION ROTORCRAFT MAINTENANCE AND INSPECTION

*James T. Moran
Air Safety Investigator
Aerospatiale Helicopter Corporation*

Introduction

Several years ago, Harry Reasoner made a rather tongue-in-cheek comparison between pilots who fly fixed-wing aircraft and pilots who fly rotary-wing aircraft. The paraphrased statement indicated that fixed-wing pilots were extroverted, happy-go-lucky, bright-eyed people who could not understand who people actually paid money to have them perform their day-to-day duties; while on the other hand, helicopter pilots were beady-eyed, neurotic little people who know that if a catastrophic failure of some sort has not already happened, it is about to. This is due to the fact that rotor-wing aircraft are viewed by the pilots and maintenance personnel as 3,000 pieces of metal fatigue surrounding an oil leak, and these combined pieces don't really fly, but rather beat the air into submission.

Due to the different environments that the helicopters operator in (i.e., high vibration levels, high torque levels, corrosive environments), a higher level of diligence is required by maintenance

personnel.

Standardization of Inspection, Maintenance and Repair Manuals

Maintenance and inspection manuals come in a wide variety of shapes, sizes and formats. Although the majority of manufacturers have gone to the ATA Specification 100 Type System, there are still gaping differences in the way material is presented to the mechanic. Although the ATA System provides mechanics a standard format for finding material in maintenance manuals, once that material is found its presentation differs greatly among manufacturers.

A standardization of language used in manuals is becoming increasingly necessary as the rotary-wing aircraft on the market attain greater degrees of sophistication. For example, turbine temperatures are expressed on different aircraft as: EGT, T4, T5, TIT and TOT. Although the areas of pick-up for these temperatures differ slightly among engines, all of the figures produce the same information. The same confusion applies to the nomenclature of turbine sections of the same engines are referred to as either N2, NTL, NF, N OR NP. Admittedly, there are some differences in the operations between a free-turbine engine and a fixed-shaft engine. However, the number of different names outweigh the differences by far.

Licensing of Mechanics

In discussions with some of the larger helicopter operators in the United States, it has been observed that as the sophistication of aircraft becomes greater, the possibility exists that the necessity of "type rating" mechanics in different aircraft will arise. Although presently operators, in conjunction with insurance companies, limit the duties of certain mechanics to their experience level, there is no regulation pertaining to this. At the very least, consideration should be given to making it mandatory that aircraft above certain weight limits and complexities require factory-trained mechanics to perform the needed maintenance. This also applies to the level of maintenance which should be allowed to be performed on different type aircraft. An A&P mechanic with an Overhaul Manual and no training can be very dangerous. Attempts are presently being made by the manufacturers to contain such activities. However, lack of regulation in this area makes the job difficult.

Consideration should be given to bringing the FAA Regulations more in line with the Canadian Aviation Regulations which require licensing by aircraft type for mechanics, even after they have been to an approved manufacturer's maintenance school.

Initial Airframe and Powerplant Mechanic Training

Under present day standards, there are no requirements for an A&P School to provide a potential mechanic with any training in rotorcraft maintenance. This means that a mechanic in today's market can conceivably finish his license requirements never having been any closer to a helicopter than seeing Airwolf on television.

It has long been known that schools teach the requirements for the FAA test, and the test borders on being antiquated. There presently are sections of the initial training which deal with

woodwork, welding, fabric skin repair and radial engines, which the mechanics will never see once they finish the curriculum they are enrolled in. Perhaps maintenance schools should take a cue from flight schools, which divide training into different phases. First phase would be initial entry level maintenance on all aircraft to cover standards and practices and other topics described in AC 43.13-1A. Later phases of training could be devoted to either rotorcraft or the more advanced maintenance techniques required by the air transport industry. Having additional certifications such as these stamped on a mechanic's license would make him more valuable to the operators of different aircraft and put the mechanics in a better position to obtain gainful employment.

Dynamic Components and Service Life Limited Parts in Rotary Wing Aircraft

Certain parts in aircraft, to include the dynamic components in the rotor head, tail rotor, drive trains, and gearboxes, are "service life limited" should never be confused with "time before overhaul," a term used in the fixed-wing market mostly connected with fixed-wing powerplants and components. A properly maintained helicopter should have separate logs and "serviceable" cards for all life-limited parts. Over the years, many catastrophic accidents have been attributed to having aircraft parts reinstalled that have reached their useful fatigue life, been "overhauled," and returned to service. Having your alternator go out on a Beech Bonanza while in flight is "disturbing." The loss of a main rotor blade in flight could add a new dimension to that term.

Constant vigilance by mechanics and supervisors is becoming more and more necessary with today's generation of helicopters. Small things like following the Standards and Practices sections of maintenance manuals, and giving particular attention to the corrosion protection sections of the aircraft inspection and repair manual can go a long way in reducing the accident rate, which has already been substantially reduced over the past ten years.

Perhaps some day we can improve rotary wing maintenance to the point where our "beady-eyed, neurotic little pilots" become the "extroverted, happy-go-lucky" ones they once were.

NONDESTRUCTIVE INSPECTION EQUIPMENT AND PROCEDURES

George Ansley
NDT Specialist, Service Engineering Department
Boeing Commercial Airplane

This presentation describes the inspection techniques known variously as nondestructive testing (NDT), nondestructive testing (NDT), nondestructive inspection (NDI), and nondestructive examination (NDE). The principal methods used today to support nondestructive testing include:

- X-ray. These procedures have been in use for roughly 50 years. X-ray can detect anomalies in metal just as in bone during medical examinations.
- Ultrasonics. Alterations in patterns of reflected sound waves are used to pinpoint

structural faults. Technically, this is the most difficult **NDT** method.

- Eddy Current. This is an electronic inspection method in which disturbances in an eddy current indicate a metal fault. Probably 90 percent of the **NDT** inspections made today use this procedure.
- Penetrant. In this procedure, a dye is applied to the metal and then examined with different lighting sources for indications of unusual stress patterns. This is a well-known inspection procedure.
- Magnetic Particle. This procedure is limited to the inspection of steels that can be magnetized and is commonly used in overhaul situations where parts are taken from the airplane, completely disassembled, and inspected.

The above are referred to generically as methods, i.e., eddy current method. When these methods are presented in specific written instructions for aircraft inspection they are referred to as procedures.

The primary method of aircraft examination is by visual inspection. This remains the best inspection method, with possibly 95 percent of an aircraft being inspected visually. **NDT** procedures are used to supplement the visual inspection and, in general, are used in lieu of a costly tear-down process in which much hardware is removed to get to the structure requiring inspection. NDT procedures are effective and also control costs. Finally, NDT procedures can be used for reliable detection of smaller defects than could be found visually.

Figure 1 illustrates the use of a nondestructive inspection. Some years ago we did a tear-down inspection of an older airplane and found small cracks in the lower wing surface spanwise splice stringer. This stringer goes through the fuel tank, so the first visual evidence of such a crack would be a noticeable fuel leak on the underwing surface. Other than the surface inspection, the only other visual option consists of draining the tank, climbing inside, scraping sealant, and performing a visual check there of each of the 7,000 fasteners. It is our position that such an inspection simply is impossible. A nondestructive procedure must be used.

**Approximately 7,000 fastener locations per airplane;
inspection time: 2 men- 8 hours=16 man hours.
There is no viable inspection option.**

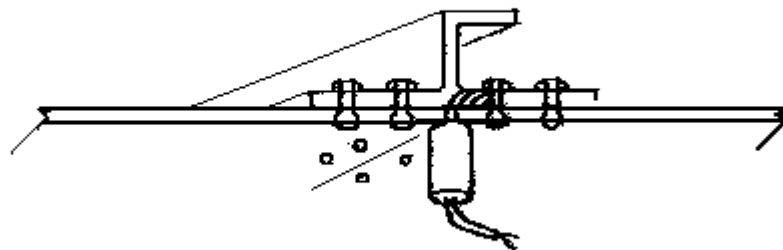

Figure 1 Example of low frequency eddy current inspection of lower wing surface span-wise splice stringer.

The **NDT** inspection used for the splice stringer consists of centering an eddy current probe in place and sliding it slowly the full length of the wing to detect possible cracks in the underlying member. Inspection time for the 7,000 fasteners is approximately 16 man-hours. Obviously, the NDT procedure is superior to a visual inspection. However, it comes with its own problems. Since this is a lower wing surface, typically one man holds the eddy current equipment while the other applies the probe to the aircraft while standing on a short ladder. The inspector thus is leaning back while looking straight up. This is quite uncomfortable and can only be tolerated for short periods of time. However, in our mind, this inspection procedure is mandatory. There is no viable option.

The basic eddy current inspection in use today is illustrated in **Figure 2**. This shows the high frequency eddy current probe inside a fastener. Generally, the inspection in use today is illustrated in Figure 2. This shows the high frequency eddy current probe inside a fastener. Generally, the inspection probe is calibrated against a test base with a thirty-thousandth inch notch. If a crack of this extent is found during the inspection of a fastener hole, the hole is drilled and repaired. For the remaining holes, we assume smaller cracks are present even though the required eddy current inspection shows nothing. We then oversize each of these good holes about 1/16 the of an inch and refasten the structure with oversize bolts. This procedure is called out in many of the Service Bulletins we have issued.

High frequency eddy current fastener hole inspection to detect cracks. 0.030 inch or larger.

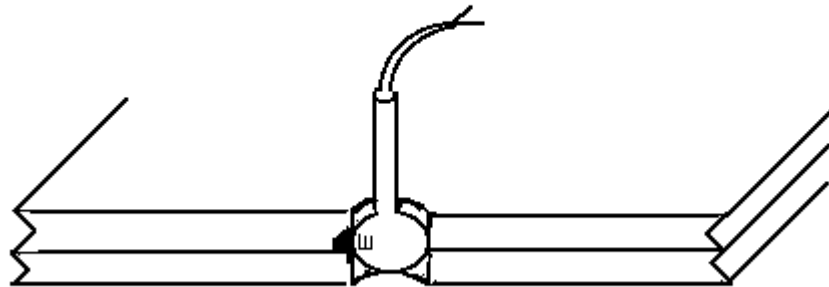

Figure 2 Examples of non-destructive inspection to support structural repair or modification

NDI Procedure Development

The Boeing Company maintains a well-equipped **NDT** laboratory, with an extensive investment in equipment, which is used to study NDT procedures and to validate the inspection requirements we describe in Service Bulletins. In a sense, we work for the airlines as we try to develop the most practical and effective options to visual inspection in maintenance programs. For the most part, the procedures we develop are considered mandatory since the alternative,

taking the airplane apart to examine internal systems visually, generally is not feasible.

The **NDT** laboratory also considers field conditions when developing an inspection procedure. For example, some eddy current and ultrasonic instruments provide the readout on an oscilloscope rather than a meter. This works fine in the laboratory. However, we deal with airlines all over the world, a great many of which operate in the tropics. For an outside inspection or in a hangar without doors, the sunlight simply is too bright for an oscilloscope to be used. Therefore, we look to alternate procedures or equipment that will be effective in the various environments in which they will be used.

We also take into account cost of equipment to the airlines and training requirements imposed on inspectors. For example, when the FAA made the first low frequency eddy current inspection mandatory, we conducted a school for inspectors to insure that these inspections would be conducted properly. While the equipment and training does present an additional cost burden to airlines, there appears to be no alternative.

Much laboratory work is concerned with establishing procedures and standards for critical crack detection. We know that a crack grows slowly as metal fatigues, and that as the crack gets larger its rate of growth increases. Our Stress Department develops information on crack size versus aircraft landing cycles. In how many cycles does the crack go critical? From these data we establish inspection intervals, as shown in **Figure 3**. Our Service Bulletin philosophy is that we want two opportunities to detect that crack before it reaches critical size.

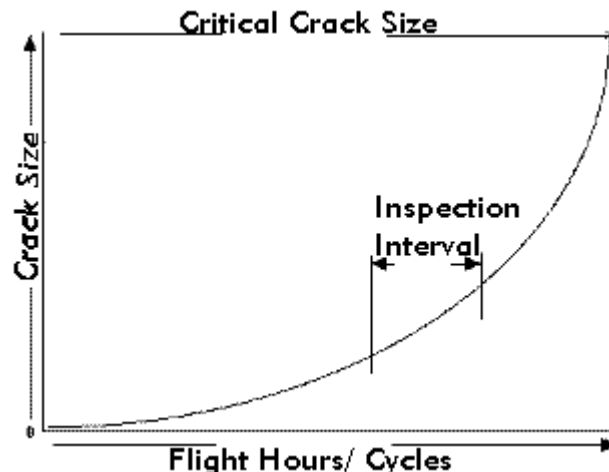

Figure 3 Establishment of NDI inspection intervals to ensure detection before cracks become critical.

We also consider inspection options from an airline's point of view. If I can allow for a larger defect in a Service Bulletin, the inspection will be easier technically, a less expensive piece of equipment can be used, and the inspector might not require as much training. The disadvantage, however, is that the inspection interval must be shorter. For instance, the inspection might have to be made every six months. This is inconvenient since the airplane is not available for scheduled maintenance that often. Therefore, we can stretch the inspection interval by dealing

with a smaller defect size. In turn, this may require special instrumentation and training. The inspection itself might be slow and tedious. These are difficult tradeoffs to consider.

Lap Splice Inspections

Considerable attention has been given recently to the 737 aircraft because of cracks discovered in the fuselage lap splice. At the splice, fuselage skins are thin, each of them only thirty-six thousandths of an inch. Because of these thin skins, the base of the countersink for a rivet tends to be a knife-edge, which is a poor fatigue detail. To counteract this, the aircraft were constructed with a cold bond system using epoxy over a thin layer of dacron or glass cloth as a means of distributing the load. The bonding shares the load with the fastener and picks up enough of the load so that a fatigue crack should never develop.

We found with older airplanes that over a period of time, in the order of five years, the bonding material begins to deteriorate with moisture and you begin to lose the load-carrying capability that the bond gave you. Fatigue cracks then can form in the upper row of fasteners, as shown in **Figure 4**.

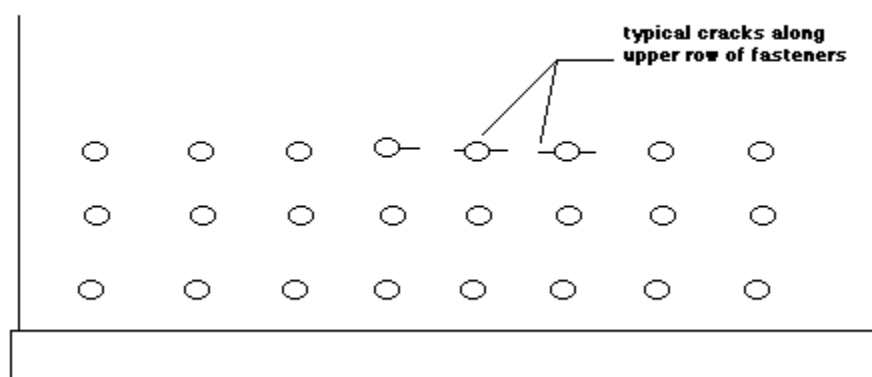

Figure 4 737 aircraft fuselage lap splice inspection.

Because of the potential for crack formation, there now is a mandatory eddy current inspection of the top row of fasteners in the 737 airplane. The required area covers 659 inches, or 55 feet, of lap. Being roughly one inch apart, there are 659 fasteners in each lap and four laps to be inspected.

The inspection is mandatory. However, there are various techniques for conducting an eddy current inspection. These include:

- Pencil probe/template
- Pencil probe/oversize template
- Rotating probe
- Sliding probe
- Freehand pencil probe

All of the above are variations on a theme. To illustrate their use, I will describe those frequently employed at this time.

Use of the pencil probe/template technique is shown in **Figure 5**. The inspector visually centers the template on the fasteners, then takes the pencil probe and scans the fastener looking for a telltale which of the needle on his eddy current display instrument. The inspector must center the template before he can move the pencil probe. While working, he holds the instrument in one hand, scans using the pencil probe with the other, and watches the meter. Since this must be done for every fastener, this can be a laborious inspection.

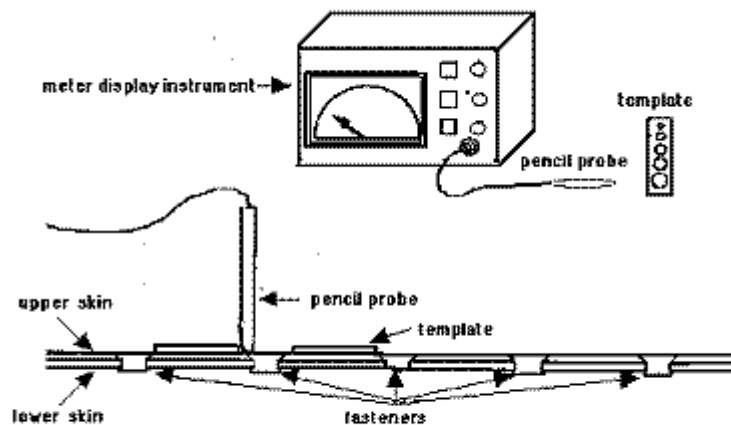

Figure 5 737 aircraft lap splice eddy current crack inspection using pencil probe/template techniques.

Figure 6 shows the key characteristics of the pencil probe/template technique. Detectable crack size is forty thousandths of an inch from the shank. Since 6 to 8 hours are required per lap, approximately 24 to 32 hours is required to do one airplane.

Detectable Crack Size	0.040 Inch From Shank
Estimated Inspection Time	6-8 Hours Per Lap
Required Equipment	Meter Display Instrument, Pencil Probe, and Circle Template
Inspection Advantages and Limitations	<ul style="list-style-type: none"> * Sensitive to Very Small Cracks -Permits Economic Rework * Very Tedious * Detects Cracks in All Directions

Figure 6 Inspection parameters for 737 aircraft eddy current crack inspections using pencil

probe/template technique.

With use of an oversize template, as seen in **Figure 7**, inspection time can be reduced to 3 to 4 hours per lap. However, detectable crack size increases to 90 thousandths of an inch. So we have shortened the hours but reduced the sensitivity of the technique.

Detectable Crack Size	0.090 Inch From Shank
Estimated Inspection Time	3-4 Hours Per Lap
Required Equipment	Meter Display Instrument, Pencil Probe and Circle Template
Inspection Advantages and Limitations	* Detects Cracks in All Directions

Figure 7 Inspection parameters for 737 aircraft eddy current crack inspections using pencil probe/oversize template technique.

Figures 8, 9, 10, 11, 12, and 13 show the techniques and characteristics for the sliding probe, the rotating probe, and the freehand pencil probe systems. Note that inspection time can be reduced to one to two hours per lap with the freehand pencil probe system. However, detectable crack size is only two-tenths of an inch. A summary of characteristics for all of these eddy current crack inspection techniques is presented in **Figure 14**.

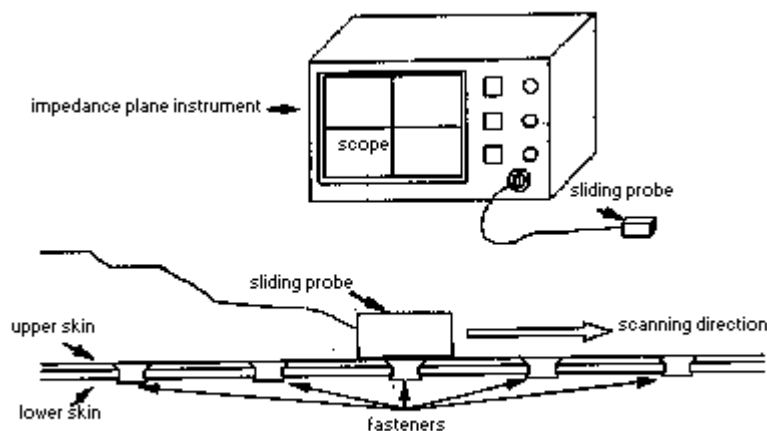

Figure 8 737 aircraft lap splice eddy current inspection using sliding probe technique.

Detectable Crack Size	0.090 Inch From Shank
Estimated Inspection Time	2-3 Hours Per Lap
Required Equipment	Impedance Plane Scope Instrument and Nortec SPO 3806 Sliding Probe
Inspection Advantages and Limitations	<ul style="list-style-type: none"> * Requires Only One Scanning Direction * Maximum Probe Off-Center +/- 0.050 Inch * Detects Cracks- 45 Degrees to + 45 Degrees From Fastener Line * Oversize Fasteners May Give Crack Indications

Figure 9 Inspection parameters for 737 aircraft eddy current crack inspections using Sliding Probe Technique.

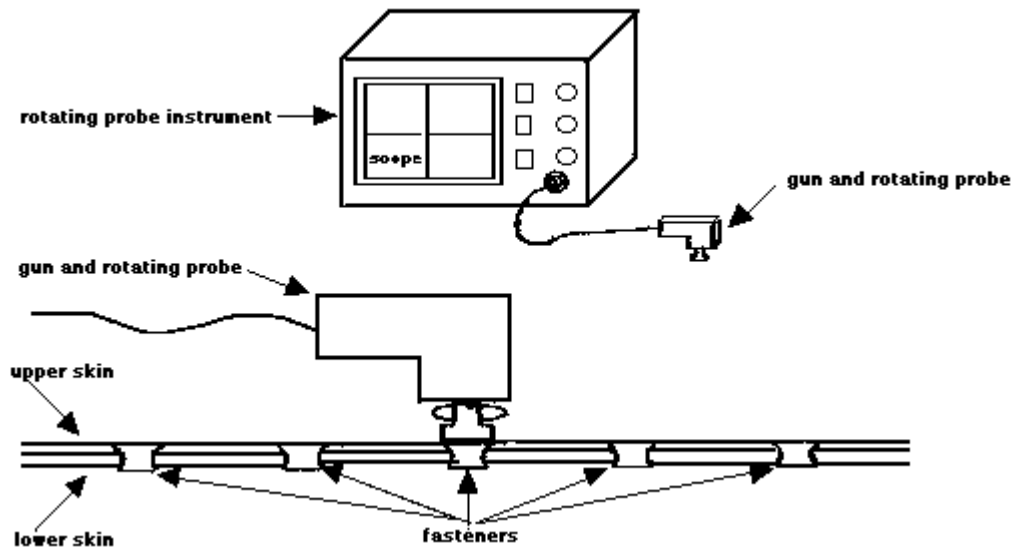

Figure 10 737 aircraft lap splice eddy current crack inspection using rotating probe technique

Detectable Crack Size	0.065 Inch From Shank
Estimated Inspection Time	2-3 Hours Per Lap
Required Equipment	Rotating Probe Instrument and Rotating Probe
Inspection Advantages and Limitations	* Detects Cracks in All Directions * Oversize Fasteners May Give Crack Indications

Figure 11 Inspection parameters for 737 aircraft eddy current crack inspections using rotating probe technique.

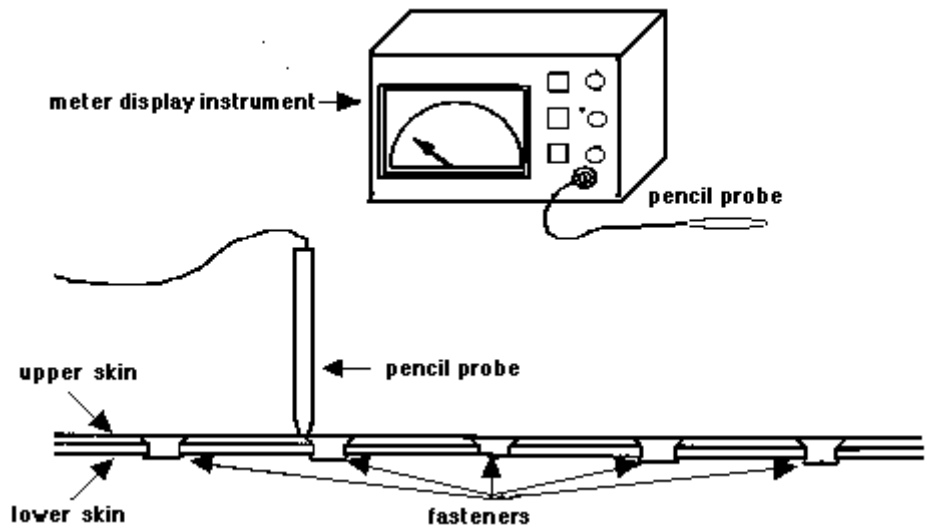

Figure 12 737 aircraft lap splice eddy current crack inspection using free-hand pencil probe technique.

Detectable Crack Size	0.20 Inch From Shank
Estimated Inspection Time	1-2 Hours Per Lap
Required Equipment	Meter Display Instrument and Pencil Probe
Inspection Advantages and Limitations	* Detects Cracks -45 Degrees to +45 Degrees From Fastener Line

Figure 13 Inspection parameters for 737 aircraft eddy current crack inspections using

full-hand pencil probe technique.

Technique	Detectable Crack Size From Shank	Estimated Inspection Time	Equipment Required
Pencil Probe/Template	0.040 Inch	6-8 Hours Per Lap	Meter Display Instrument
Pencil Probe/Ovenize Template	0.090 Inch	3-4 Hours Per Lap	Meter Display Instrument
Rotating Probe	0.065 Inch	2-3 Hours Per Lap	Rotating Probe Instrument
Sliding Probe	0.090 Inch	2-3 Hours Per Lap	Impedance Plane Instrument
Free-Hand Pencil Probe	0.200 Inch	1-2 Hours Per Lap	Meter Display Instrument

Figure 14 Summary of technique for 737 aircraft lap splice eddy current crack inspections.

There is a wide variety of excellent **NDT** equipment available "off the shelf" today. The NDT instrument manufacturers react rapidly to industry needs and are actively developing new equipment to support airframe manufacturers and the airlines.

In general, the advances in **NDT** technology and application of NDT procedures have exceeded the availability of qualified NDT personnel. Our biggest need is for skilled, trained, and experienced inspectors. The instrument manufacturers have outdistanced the supply of trained personnel to use these instruments. This is a problem we must address.

IMPROVED INFORMATION FOR MAINTENANCE PERSONNEL

*Robert C. Johnson
Chief, Combat Logistics Branch
USAF Human Resources Laboratory*

The Air Force has been working on the problem of providing proper technical information to maintenance personnel for many years. Our problem in this respect is not all that different from that of the commercial airlines. We both are concerned with the development of procedures and systems to support and enhance the performance of aircraft mechanics and inspectors.

A significant Air Force activity in this field began about 20 years ago with the Job Performance Aids (JPA) program. This program literally redefined the technical information that Air Force maintenance personnel used to repair airplanes. Before this, technical data were found in reading level, far above most of our mechanics' ability to read it. Related information was

scattered throughout a volume and possibly throughout several volumes. A mechanic had to have many books in order to follow a procedure. Procedures themselves were not clearly identified. Illustrations supporting the procedure also were scattered throughout the books. Studies run to examine the performance of maintenance personnel at that time estimated that about one-third of a mechanics' total time was spent in finding the proper information. In all, there was ample justification to begin the JPA program.

Even as job performance aids come into increasing use, the amount of maintenance data necessary to support a given airplane continues to grow. The number of pages of technical order data required to support four Air Force aircraft over a forty-year period is shown in **Figure 1**. During this time span, the number of pages of maintenance documentation has doubled approximately seven times.

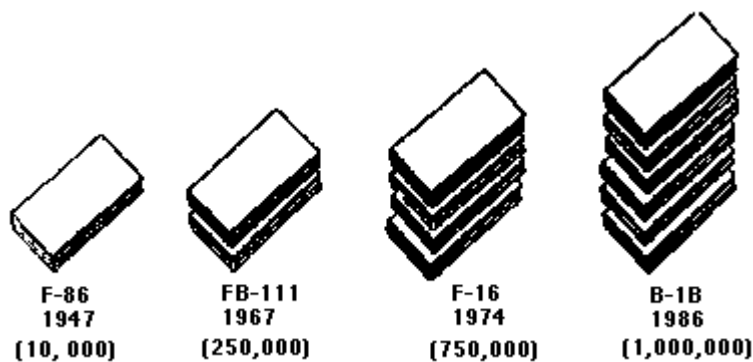

Figure 1 Pages of technical order data required for four Air Force aircraft

The voluminous maintenance documentation lends itself naturally to an automation process. Indeed, it is quite possible to automate technical data and print it out in stacks of IBM paper as one desires. While this would serve the purposes of automation, it would not serve the user's purpose of maintaining performance. For automation to be successful, it must be accomplished in a manner that supports user requirements.

Once the Air Force was committed to automation, the first step was to determine the requirements for technical information to support effective job performance. A number of guiding principles were followed in the approach to automation. First, as noted, the user's requirements had to be kept in mind at all times during the design process. It was clear that we could not take existing technical data, process it through the computer, print it out, and expect improved performance. Second, the system should employ an effective technical order content/format approach to be consistent with existing systems. A radical departure from conventional documentation would not be effective. Third, usable controls and displays should be provided to the operator attempting to access the technical data and then employ it for his purposes. Finally, user acceptance was deemed to be critical. Even though all human factors issues might be addressed, user acceptance would not be guaranteed. User acceptance is a variable in itself.

In an automation program, there are three areas of primary concern. In the Air Force program, as seen in **Figure 2**, issues of computer-aided authoring of materials is primarily a contractor

effort. Issues of automated publication and distribution are handled through the Air Force Logistics Command. The part of the effort I am concerned with, as conducted through the Human Resources Laboratory, concerns electronic delivery of maintenance information. This is delivery to the hands-on level, whether to support performance in maintenance conducted at the flight line.

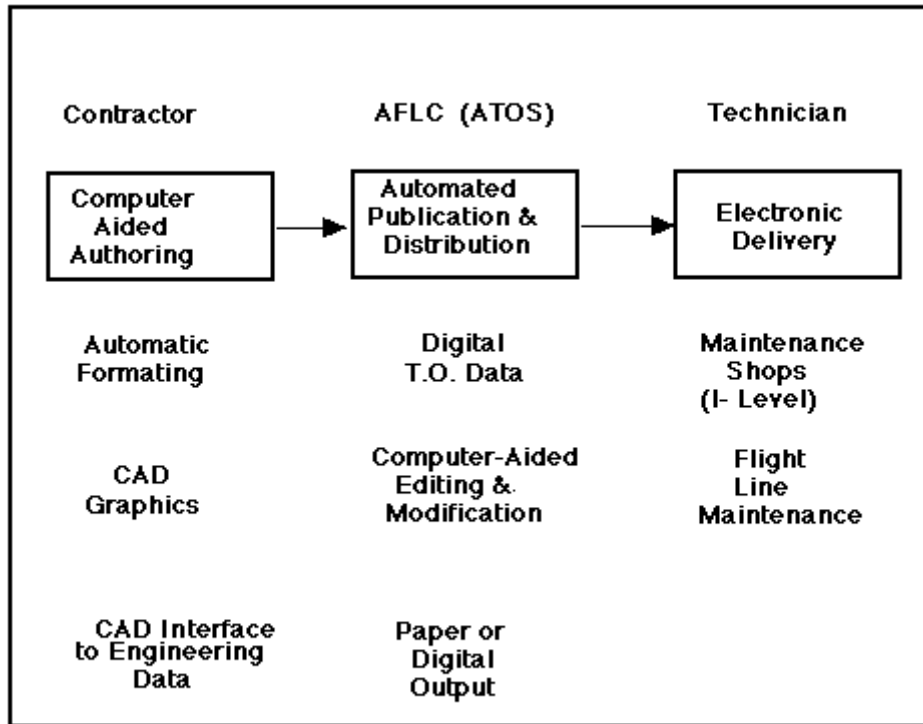

Figure 2 Areas of responsibility in Air Force integrated technical data system.

A major issue in the delivery of automated maintenance information is that such information precisely match the needs of the user. However, we in the Air Force, as do you in airline operations, have a range of experience in our mechanics and inspectors. On one hand, we have exceptionally experienced people who have performed certain tasks hundreds of times and do not actually need technical data at all, except that Air Force doctrine says that they will use it. On the other hand, we have new personnel who need step-by-step detail to support their performance. In our program, maintenance personnel are separated into three tracks according to their needs. **Figure 3** illustrates the levels of detail provided through the automated maintenance program to support a technician operation in each of these three tracks.

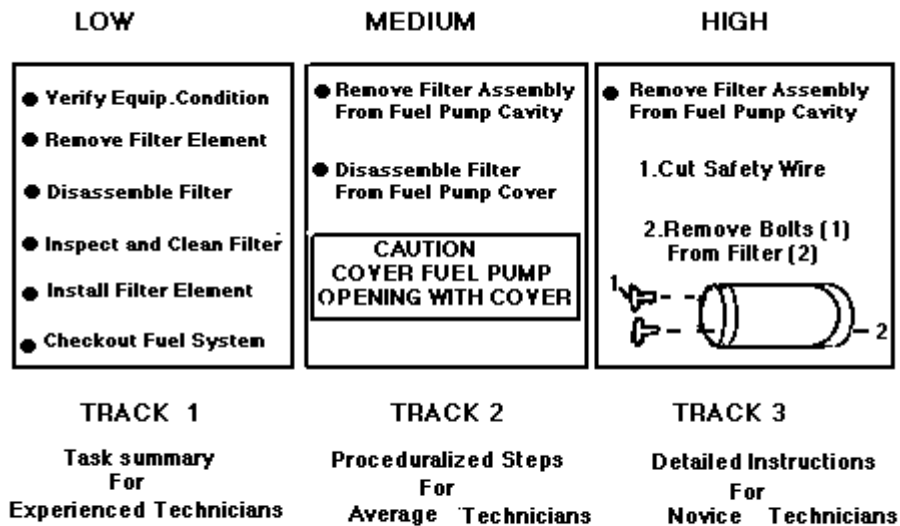

Figure 3 Different levels of detail in maintenance instruction to support technicians with different experience levels.

In 1979 I prepared a concept paper describing an Integrated Maintenance Information System (IMIS) which has subsequently turned into a major Air Force and DoD project. It was clear at that time that maintenance personnel needed more than simply the data describing disassembly and assembly of components. The needed technical information of many kinds: training data, management information data, built-in test data on the airplane, flight parameters, supply information, and possibly access to historical information. In the course of a day, a maintenance man might have to interact with virtually all of these data systems at least once and possibly more. In this case, the maintenance man would be dealing with five or six different systems with different protocols, different software, different displays, and possibly conflicting information. No one would provide him with precisely the information he needed.

The purpose of the Integrated Maintenance Information System was to provide one device that would allow a technician to interact with all data systems as if they were one. Software integration would be the key feature of the new IMIS system. At this time, we are well on our way to proving the IMIS concept and demonstrating the system in operation. The technical data to support IMIS are available. System components have been evaluated in three field tests using intermediate or shop-level automated technical data. **Figure 4** shows the major topics of concern over the period from 1985 to 1991.

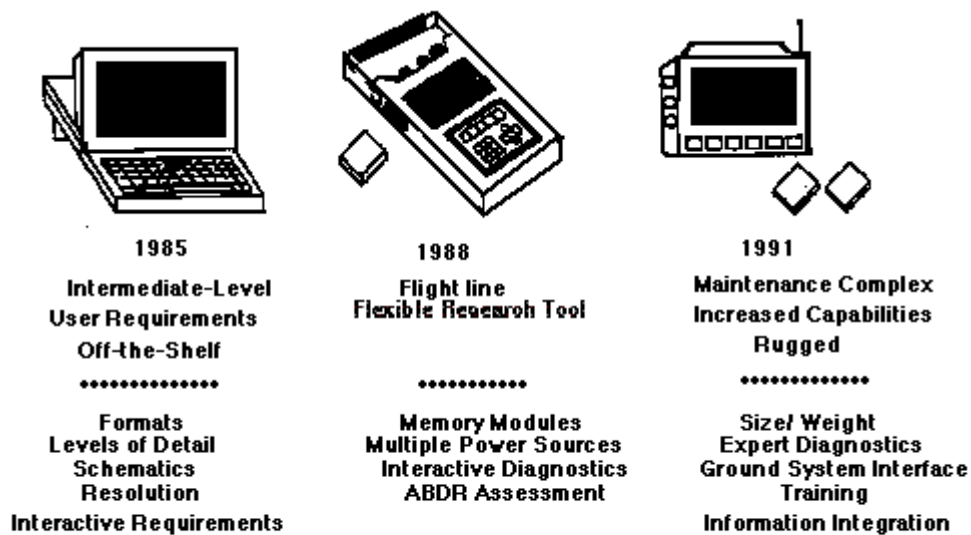

Figure 4 Three phases of the Air Force Integrated Maintenance Information System.

The principal end product of IMIS is a portable computer which will plug into the maintenance bus on one of our airplanes and download at the flight line the built-in test data necessary to troubleshoot the airplane. All automated systems on the airplane can be checked without climbing into the cockpit. Following this, the same portable computer plugs into a keyboard and turns into a maintenance workstation that allows the technician to interact with ground systems, with airborne systems, and with the range of data bases necessary to support his performance.

In February 1989, we plan to plug the portable IMIS computer into an F-16 aircraft and try the system on the flight line. We will have integration of step-by-step diagnostic procedures with supporting technical data, the two major elements of IMIS. All IMIS software will be integrated in late 1991, with the full IMIS system available in early 1992. **Figure 5** illustrates the operation of the IMIS information network at that time.

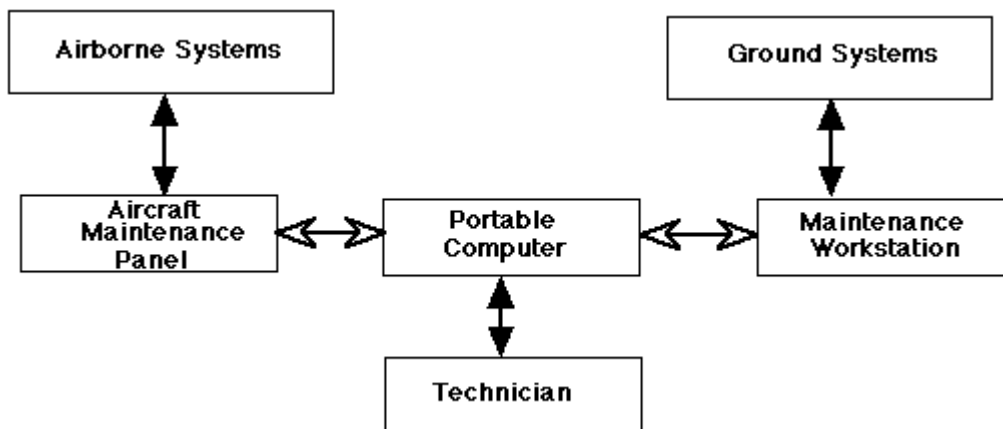

Figure 5 Operations of Integrated Maintenance Information System Network.

There remain a number of associated technologies requiring work by us to develop the IMIS system to its full potential. Some of these are (1) interactive diagnostic technology, (2) computer hardware technology, (3) data base development issues, and (4) problems of flight line operation. One of particular interest, however, is maintenance aiding technology, as shown in Table 1. For example, the size of the computer screen is a matter of genuine concern.

TABLE 1
EXAMPLE OF ONE TECHNOLOGY REQUIRING WORK TO SUPPORT
DEVELOPMENT OF THE INTEGRATED MAINTENANCE INFORMATION SYSTEM

<i>Maintenance Aiding Technology</i>	Presenting
Data on Small Screen	
Content	
Formats	
Man/Machine Interaction Techniques	
Presenting Schematics	
Enhancing Performance	
Levels of detail	
Highlight signal flow, etc.	
Computations	
Field Test	

Much of our information is presented in the form of schematics which, to be readable, are physically larger than the screen. We are working intensively with the problem of small screen presentations but, although we have made progress, we do not have the necessary answers as yet. We also are continuing to work on problems of man-machine interaction, although we feel this is an advanced technology at this time. We still need to know, however, precise levels of detail to use for a technician at a given level of training performing a specific task. We also need to understand proper procedures to highlight signal flow through a schematic and it illustrate required computations. Finally, there is more work to be done on defining optimum procedures for field testing a system such as IMIS so that the test provides all information to support ongoing improvements.

While the Air Force has a specific military mission, its requirement for quality aircraft maintenance information that we have developed over the years can prove useful for the nation's civilian aviation industry, so much the better.

Strengths and Problems in Maintenance Training Programs

Richard Hlavenka
Division Chairman
Tarrant County Junior College

This presentation describes the manner in which training for aviation maintenance is being conducted in colleges at this time and the way we relate to the different segments of the aviation

industry. I would also like to dispel certain misconceptions about our training programs. Finally, I would like to discuss some human factors pertaining to the scope of maintenance training today.

Perhaps the best way to introduce the topic of maintenance training is to describe briefly the program at Tarrant/Fort Worth Municipal Airport, some three miles from the main campus. The school operates on a semester system, with two semesters each year plus a single summer session. Students who enter our program fall into three basic groups. First, there are those who are studying to enter the field of aviation maintenance but who have no prior experience. These students typically have been out of high school from one to ten years. Second, we have those who already involved in aviation and are looking to upgrade their skills. In some cases, these are individuals who feel the airframe and power plant mechanics license will allow them to move to a better position at their present employment. Finally, we have those individuals with unique reasons for being in the program. For example, some are professionals who own aircraft and want to understand their airplane better and possibly do some part of their own maintenance. Of these three groups, the largest number are those seriously interested in entering aviation maintenance as a profession.

Tarrant County Junior College is similar to the other 140 or so FAA approved and certified airframe and power plant mechanic program requires approximately two years to complete the core curriculum. During this time, a student becomes fully qualified to take the FAA examination. We also offer the student an option to continue into a two year Associate Degree program. Here we offer additional academic courses, usually in the areas of mathematics, science, and communications. Beginning this year, we will also include a course in human relations and a course in speech. It is estimated that over 90 percent of those graduating from the core two-year program continue on and are awarded the Associate of Applied Science Degree.

For the past several years, the majority of our students have been employed by the major airlines immediately upon graduation. In the past two years, most have gone to work for American and Delta. We are proud of the fact that, for the first time in the Dallas/Fort Worth area, American Airlines has started hiring our graduates and putting them directly on the floor with other mechanics. Thus, while we recognize an ongoing need for certain improvements within the program, we do feel that this certainly illustrates our program's effectiveness.

Within Part 147, there is considerable flexibility as to the way in which a school can cover required topics. For example, we are still required to teach dope and fabric techniques, even though the number of fabric covered aircraft in the national inventory certainly is limited today. However, Part 147 does not specify whether this topic requires one hour or 500 hours of training. In our particular program, we offer 24 hours of dope and fabric procedures. In this time, we teach students of the need for the procedure, how it is performed, and problems incurred with its use.

One problem we faced until recently concerned getting students into the program who were academically qualified. About four years ago, we were experiencing approximately a 30 percent drop-out rate among students who entered the first semester of our aviation maintenance program. This caused us some concern, particularly since our enrollment is limited and we were having to turn away students each semester as we started that year's program. In order to

improve this situation, we established academic entrance standards. All students now are required to take placement tests in mathematics, reading, and English prior to entering aviation maintenance training. We now have a drop-out rate of five percent or less in the first semester of our program.

Academic instruction is continued after the student enters his maintenance training. Mathematics is continued through basic trigonometric functions. Other courses emphasize writing and communication. Upon completion of the program, our average student probably is reading at the 14 year level. We consider this skill quite important since he is required to make logbook entries, to complete Form accurately the working in Airworthiness Directives.

Turning to the problems in aviation maintenance training today, we come back to Part 147. While I have previously identified it as a strength, it also had its weaknesses. One problem that must be solved, and is currently being worked on, is that the document basically has not changed considerably during the last 20 years; Part 147 must reflect these changes. It is suggested that those of you with concerns about Part 147 make them known to the FAA as input to the study now in progress.

When changes are made to Part 147, consideration should be given to time requirements. At the moment, the FAA requires that students have at least 1900 hours of training. Our program offers 1965 hours during an intensive two-year program in which students have a total of only six weeks of free time. If Part 147 is extended to require more hours, this automatically means that schools must extend their programs. I believe this will have an economic ripple effect all through the aviation industry. At the present time, for one price an employer can buy a product - an individual - with basic entry level skills and knowledge. This individual knows how to perform aircraft maintenance, how to interpret technical manuals, and how to work on his own. If his training is extended and his skills enhanced, however desirable these may be the price of the package may well increase. This in turn would impact aviation maintenance costs in areas where operators are looking at close profit margins.

One means of dealing with the above issue could be to develop certain post-graduate packages. These specialized programs could be added to the core program and be elective. This would be a way of dealing with topics such as helicopter maintenance and repair of advanced electronics systems.

Finally, there is another topic I offer for consideration. **Table 1** shows a typical core curriculum for an aviation maintenance program. This is basically the FAA curriculum and I would like to point out one thing about it. There is nothing in it that relates to human factors or human relations. With this curriculum, we produce an individual who is strictly limited to the maintenance phase of aviation.

Table 1. Typical Core Curriculum for an Aviation Maintenance Program.

GENERAL AVIATION MAINTENANCE COURSES (17Hours)	
AER 1313	Background for Aircraft Science
AER 1323	Advanced Aircraft Science
AER 1344	Ground Operation and Servicing
AER 1364	Materials and Processes
AER 1383	Basic Electricity
AIRFRAME COURSES (29 Hours)	
AER 1333	Assembly and Rigging
AER 1335	Sheet Metal Structures
AER 1356	Airframe Electrical Systems
AER 1372	Aircraft Landing Gear Systems
AER 1374	Hydraulic, Pneumatic and Fuel Systems
AER 1392	Aircraft Covering and Finishing
AER 1402	Welding
AER 1403	Utility Systems
AER 1412	Airframe Inspection and Review
POWERPLANT COURSES (26 Hours)	
AER 2412	Turbine Engines
AER 2425	Powerplant Fuel Systems
AER 2434	Propellers
AER 2442	Powerplant Lubrication Systems
AER 2456	Reciprocating Engines Overhaul
AER 2465	Powerplant Electrical Systems
AER 2472	Powerplant Inspection and Review

It is my belief that the Part 147 core curriculum, and the profession in general, could be improved by adding some topics related to employee/employer relations. Areas of coverage could include professional ethics, professional communications, and personal commitment to one's job. I believe these to be areas that are vitally important to the aviation maintenance technician of the 1980's and 1990's.

In an expansion of Part 147, we could without great effort include newer areas of coverage such as topics concerned with "glass cockpit," etc. If we are going to do that, however, I still recommend that we include coverage of human relations topics as suggested. By doing this, we will produce a better and safer mechanic who will not only be a person who can do the job well, but also be a person who will understand the responsibilities that go along with that job.

The Human Operator as an Inspector: Aided and Unaided

*Colin G. Drury, Ph.D.
Professor of Industrial Engineering
SUNY, Buffalo*

The thrust of this presentation is toward human factors in inspection, a key element within the broader field of industrial maintenance. The objective is to point out human factors concerns in the inspection process and, in particular, to illustrate how the human inspector can be viewed as a quantitatively defined technical system.

The term "human factors" can be considered synonymous with "ergonomics," which has been defined as the science of "fitting the job to the person to enhance human efficiency and well-being." There are specific techniques to be used in fitting the job to the person. The first

activity is a systems analysis in which the objective, or end product, of the system is clearly defined. The role of the human as one component within the system also is specified, to the extent feasible, at this point. Once the role of the human has been spelled out in general terms, a task analysis is conducted. This task analysis feeds back into system design in that hardware changes may be necessary at this point to begin to fit the job requirements to the human ergonomically. This same task analysis also becomes the basis for development of selection criteria and the establishment of a training program.

The human as a system component has specific capabilities and weaknesses. Humans are incredibly flexible and constitute possibly the best general purpose device ever built. Humans can do almost anything reasonably well. However, the error rate in human performance can be high. An individual asked to perform some critical task over and over and do it exactly right every time generally will be able to do so. We have exceeded his capability in terms of reliable performance. In human factors design terms, this means it is a mistake to design a system in which 100 percent reliability is required of the human operator.

To ensure proper system design, much specific information concerning human capabilities must be obtained. Some of this comes from the field of psychology, where considerable work has been done in defining human information processing capabilities. How are data obtained, interpreted, manipulated, and acted on? The field of anatomy provides information concerning body size, reach characteristics, and other anthropometric qualities. The field of physiology, finally, provides data concerning physiological limitations for energetic and sustained activities.

One characteristic of the human component which separates it from the machine is the manner in which it fails. When seriously overloaded, a machine component will tend to fail suddenly. It will simply break. On the other hand, humans exhibit what is called "graceful degradation" where they begin to disregard things considered less important and concentrate only on the central elements of the task. By so doing, a human can maintain a significant measure of system performance beyond the point where a totally machine system will fail. However, overall performance reliability will be impaired during this period.

Reliability of human performance is a key element to be addressed during a human factors analysis. A machine, when working perfectly, generally will exhibit reliability many times better than that of a human. The object, however, is to match the human and the machine components together so that overall system reliability can be improved over that achievable independently with either component.

Much of the study of human reliability in industrial settings has centered on the inspection process, whether simple unaided inspection or that in which various devices are used to "aid" the process. Inspection can be part of production, where it provides a quality control over the production process. It can also be part of maintenance, where it serve to guide attention to components in need of replacement or repair. In the aviation industry, inspection for maintenance is of greatest concern at this moment.

In the inspection process, where we are trying to detect something, there are two things that can go wrong. A Type 1 error occurs when a good item is identified incorrectly as faulty. This is the false alarm problem, or the false replacement of a part. A Type 2 error occurs when a faulty item is missed. A Type 1 error is costly because it results in an unnecessary economic burden. A

Type 2 error generally is of greater concern since it can lead to more serious trouble later as a result of the faulty part.

In aviation, the problem is one of trying to detect a fault at an early stage rather than simply trying to detect one. However, the earlier we try to detect a fault, the more the fault looks like a fault-free item. In other words, the signal/noise ratio is very low, making detection much more difficult. Under these circumstances, we can define the percentage of Type 1 errors (E1) and Type 2 errors (E2). Performance then can be specified in terms of E1 and E2 plus "T," which is the time to do the job. An assessment of job performance then becomes a matter of examining the relationship between these three quantities.

Table 1 presents a model used in the study of industrial inspection. It is called a first-fault inspection model. While not entirely relevant to aviation inspections, it does illustrate the logic of the inspection process.

TABLE 1
PRINCIPAL STEPS IN FIRST-FAULT INSPECTION MODEL DEVELOPED FOR INDUSTRIAL INSPECTION

1. Present pre-selected items for inspection
2. Search each item to locate possible faults ("flaws")
3. Decide whether each flaw is sufficiently bad to be classified as a fault
4. Take the appropriate action of acceptance or rejection

In the fault inspection process, an item is presented to an inspector who fixates some small area, either with direct vision or with some tool, and decides whether a flaw is present. Then, as shown in step 3, the inspector decides whether the flaw is sufficiently bad to be classified as a fault. Finally, he recommends the appropriate action of acceptance or rejection. **Figure 1** shows the logic of inspection in flow chart forms.

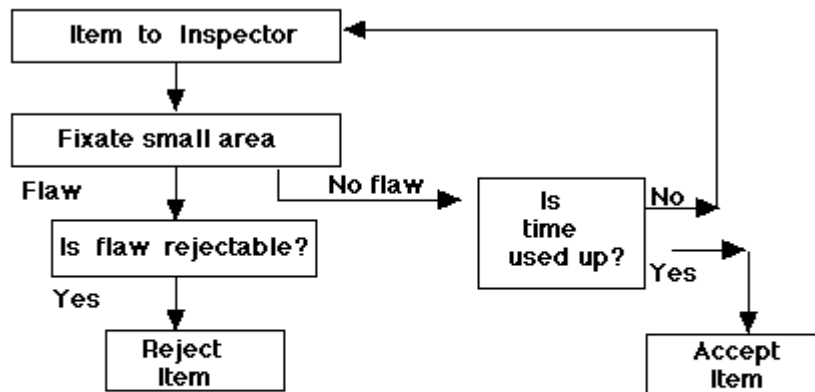

Figure 1 Flow Chart depicting the process of inspection.

The fault inspection model of **Figure 1** can lead to interesting conclusions concerning the inspection process. First, to commit a Type 1 error, the rejection of a good item, one must make two errors. The inspector first must find a flaw that is not actually severe enough for rejection and then must make an incorrect fault classification decision.

To make a Type 2 error, acceptance of a faulty item, the inspector can make either one of two errors in parallel. The inspector can either fail to find the flaw or he can find it and make the wrong classification decision. Thus, everything else being equal, one would expect many more Type 2 errors (defects being accepted) than Type 1 errors (good items being rejected). So immediately we do not expect E1 and E2 probabilities to be equal.

Of the four tasks presented in Table 1, the first and last are relatively reliable operations. If the system is designed well, these two should not represent a problem. The other two, the search and the decision-making phases of inspection, are points where there is a high chance for human error. Therefore, attention will be centered on these phases.

The search phase of visual inspection can be influenced by several factors. For example, **Figure 2** shows the reduction in visual performance during a test in which a known flaw was presented at different eccentricities, or angle from the line of central vision. Results show a steady decrease in search effectiveness as the flaw is moved away from direct vision. At 20 degrees off axis, subjects could identify a defect with a 10-minute visual angle size. At 40 degrees off-axis, the detectable size increased to 20 minutes. While this is for one type of target, comparable results can be found for other sizes and for different conditions of illumination. The important point is to recognize that any detection task which requires peripheral vision will be less efficient than one relying completely on central vision.

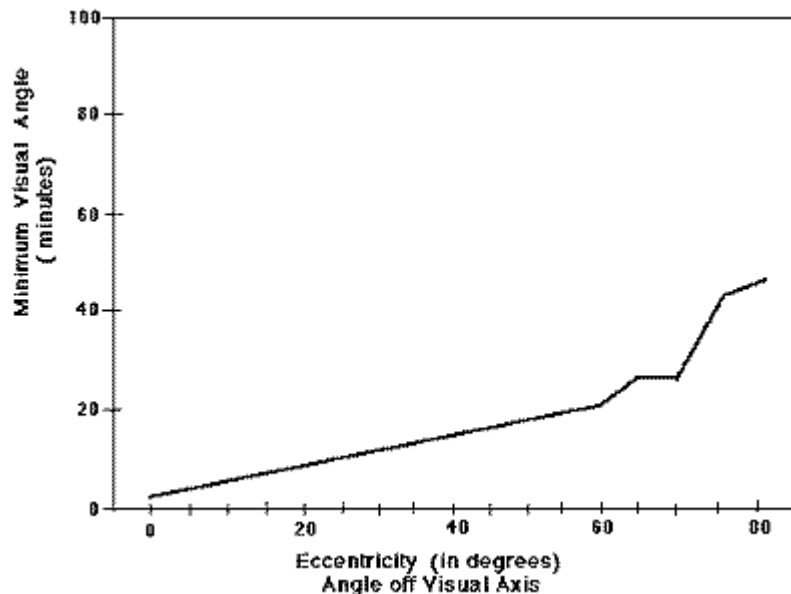

Figure 2 Decrease in visual acuity as target is moved from line of direct vision.

In studying visual detection, a human factors engineer is concerned with visual lobe, that is, the

area around the line of sight within which a fault can be detected. Factors affecting lobe size include the size of the target, or fault; the amount of light placed on the target, and in turn the eye; and the contrast between the target and its background. All of these variables may be manipulated in an effort to increase the visual lobe size and hence either reduce the time required to do the job or reduce the errors made during job performance.

Another factor with a dramatic effect on visual search performance is search time, as shown in **Figure 3**. These results show that, when a difficult-to-detect target is used, a search time of two seconds will result in only 20 percent of the faults being identified. If the search time is increased to six seconds, 80 percent of the faults can be found. This is a direct speed/accuracy tradeoff curve. When longer search time is allowed, more faults will be identified. Note also in Figure 3 that making the fault easier to detect (larger visual lobe size) gives 100 percent detection at two seconds per item.

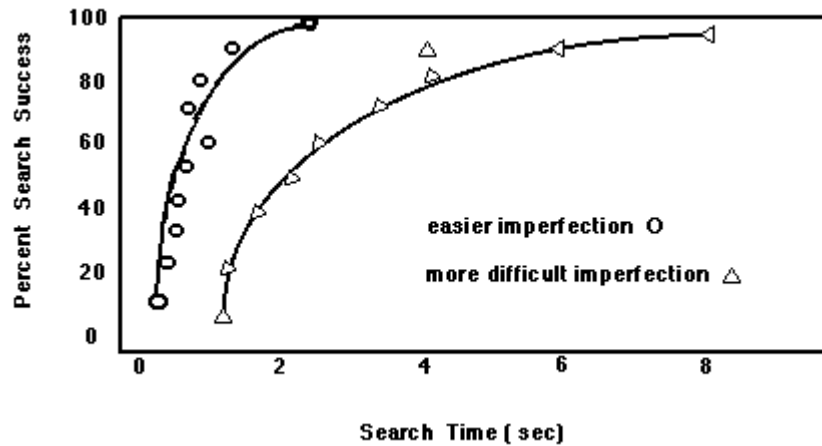

Figure 3 Cumulative probability of detecting two different imperfections.

An examination of the decision-making task also reveals some interesting features. Here there are two aspects of performance, as noted earlier. **Figure 4** plots these two aspects, i.e., the percentage of faulty items being rejected (100-E2); the percentage of good items being accepted (100-E1). In Figure 4, perfect performance is represented in the top left corner. At this point, 100 percent of good items are accepted and 100 percent of faulty items are rejected, the ultimate goal of the inspection process. Figure 4 shows the results taken from seven inspectors in an industrial operation. The data point at the bottom shows an inspector who is accepting over 90 percent of the good items but is finding only 25 percent of the faults. On the other hand, the inspector at the top is finding 80 percent of the defects but, unfortunately, is rejecting almost 50 percent of the good items.

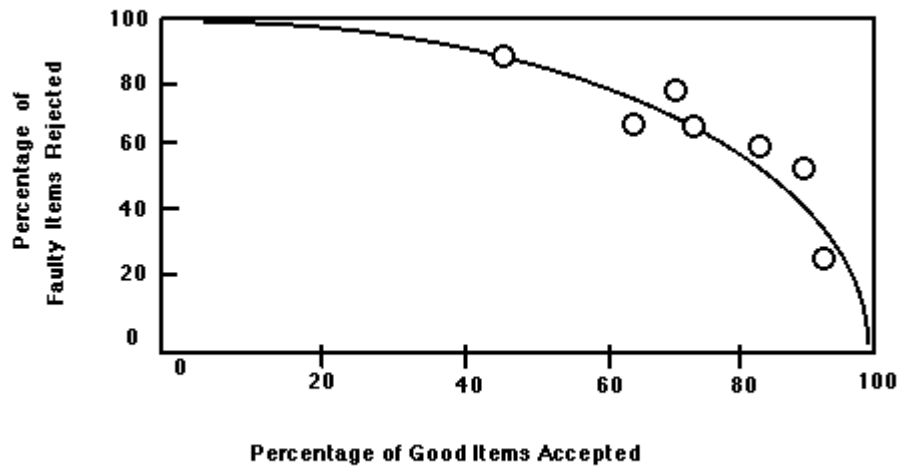

Figure 4 Performance of seven inspectors in an industrial operation.

The results in **Figure 4** tell us something about the decision criteria used by inspectors. The individual at the bottom is using a criterion which says "Unless something is really bad, I'm not going to report it." The person at the top, on the other hand, is using a criterion which says "I am going to report the slightest flaw I can see." Neither criterion is acceptable. Improved training for on-line inspectors is required.

Improved training is only one requirement dictated by **Figure 4**. The real need is to move all points on the curve toward the upper left corner. Use of signal-detection theory is of value in deciding how to proceed. Basically, this tells us that the signal-to-noise ratio must be increased. What makes the curve so bad is that there is considerable noise mixed with the signals. Achieving an increase in signal to noise can be a difficult matter, but there are many ways one can make improvements in that direction.

Signal detection theory tells us that detection criteria can be expressed mathematically, to show that two factors influence the inspector's choice of criterion. One is related to the prior probability of a signal being a real signal. The more a person expects to see a signal, the more likely he is to call any aberration a signal. So, as the probability of a signal increases, inspectors modify their criteria. Secondly, the inspector's perceived costs of error and rewards for good performance affect the criteria. As the costs and payoffs balance towards either acceptance or rejection, inspectors modify their criteria appropriately.

A major concern in maintenance inspection is the time pressure. **Figure 5** illustrates the effect on inspection performance of increasing inspection time. Here, inspection time was increased by a factor of one, two, and three times the normal. With this increase, the probability of rejecting a faulty item increases. More and more faults are found. Not all are found because the line does not level at 100 percent. It's final level depends on the decision performance. At this point all

search is complete and the inspector is now into decision, so that the curve is decision limited. On the left side of the curve, the search has not been completed, so it is search limited.

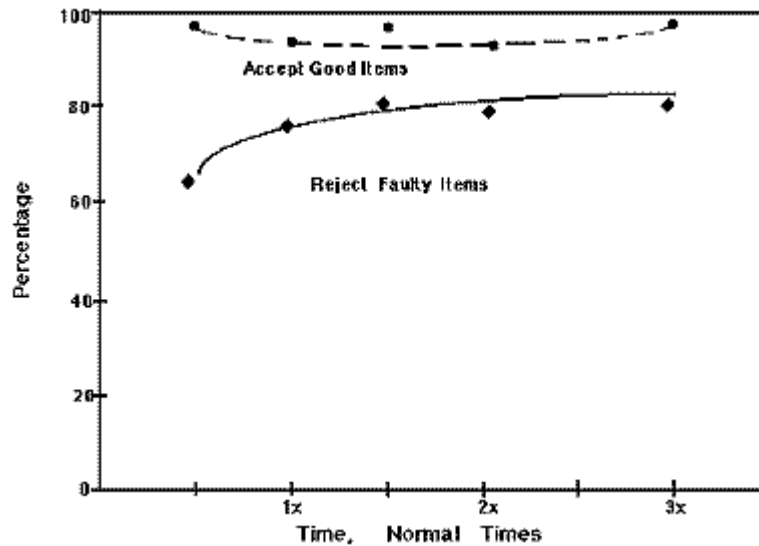

Figure 5 Effect on inspection performance of increasing inspection time.

The upper curve of **Figure 5**, the probability of accepting a good item, shows a marginal decrease in performance with increased time. This simply means that as individuals are given more time to search, they are more likely to be successful in finding something, whether a real fault or not a real fault. More false alarms are produced with excessive search time.

The above data illustrate some features of inspection theory. Search theory and signal detection theory together offer guidance concerning ways to improve the inspection process. A number have been mentioned. Target/background contrast can be increased. Search time can be adjusted optimally. Operators can be trained to use appropriate search criteria. Defect size, unfortunately, is a variable not subject to manipulation, although the size of an acceptable defect can be varied.

Another feature which can be varied is the feedback given an inspector concerning his success. **Figure 6** shows performance on a task where, as marked, a change in feedback to inspectors was made. They were simply provided more rapid feedback to inspectors was made. They were simply provided more rapid feedback as to how well they were doing. This made a significant change in their discrimination of flaws and effectively halved the number of errors. For a given false alarm rate, it halved the number of misses. For a given miss rate, it halved the false alarm rate. Their performance was essentially doubled by providing more rapidly. This makes sense when one realizes that without rapid feedback, the inspection loop is open for longer periods of time and increased errors can occur without the inspector being aware of them.

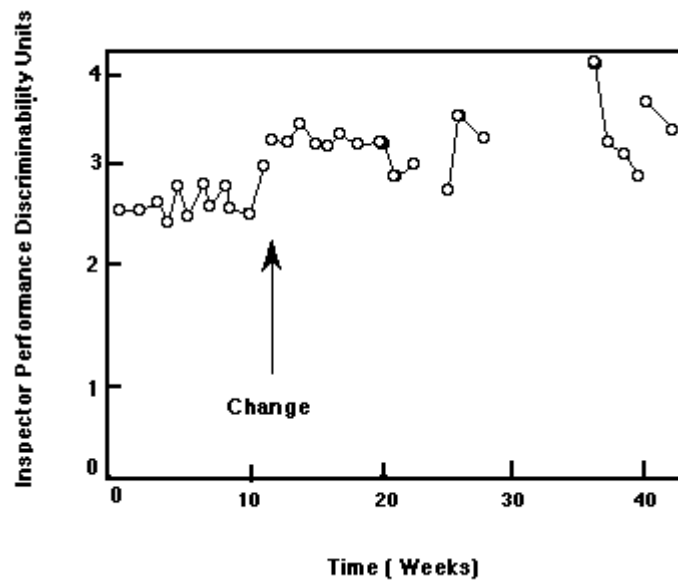

Figure 6 Effect of providing more rapid feedback on inspector performance.

In summary, human factors has grown into a scientific discipline in which the role of the human operator in an industrial system can be examined in terms of well-developed models and mathematical relationships. Improvements in aircraft maintenance and inspection can be achieved with proper application of tested human factors procedures for performance enhancement.

VIGILANCE AND INSPECTION PERFORMANCE

Earl L. Wiener, Ph.D.

*Professor, Department of Management Science and Industrial Engineering
University of Miami*

Vigilant behavior initially was studied as a problem in its own right. In time, however, a bridge was made between the world of vigilant behavior and that of inspection performance. Certainly, what we have learned through the years about human vigilance will be of value as we consider problems in the inspection of systems and materials.

Vigilance research shows the human to be a poor monitor. Yet this same research illustrates opportunities for management intervention to improve vigilance. Human factors engineers can contribute to this improvement through their understanding of vigilance and its relation to inspection.

The routes of formal vigilance research can be traced to wartime experiences during World War II. At that time, the British Coastal Command was flying long anti-submarine patrols over the Bay of Biscay, searching by radar for surfaced German submarines. These missions were long, lasting for over 10 hours. During these missions, a navigator or a pilot on occasion would walk

past the radar operator's position, look at the radarscope, and reach over the operator's shoulder to say, "Hey, there's one right there." The person least qualified to detect radar targets, who happened to be just passing by, spotted radar signals that had not been seen by the radar operator.

Problems of radar detection became so severe that a laboratory investigation was begun at the Medical Research Council under Dr. Norman Mackworth. These studies demonstrated that the longer operators were on patrol, the less likely it was that they could detect a submarine. This was one of the first findings of vigilance research.

Vigilance refers to the likelihood that a human will respond to a signal, so vigilance can be defined operationally in terms of probability. Vigilance differs from an inspection task in that it is event driven; the signal occurs in real time in the real world. You either see the submarine now or it is gone. With inspection, you frequently have an opportunity to go over the inspection a second time.

Another characteristic of a vigilance task is that the signal is subtle; it is hard to detect. Another way of saying this is that the signal-to-noise ratio is low. Also, there generally is a low signal rate. Targets do not appear frequently. Finally, there is temporal uncertainty. This, of course, makes the task unpredictable. We do not know if a signal will appear in so many seconds or in so many minutes.

There is a short test which can be used to demonstrate some of the issues in vigilance. Done properly, the following sentence is projected on a screen for 15 seconds:

**FINISHED FILES ARE THE RESULT OF YEARS OF SCIENTIFIC STUDY
COMBINED WITH THE EXPERIENCE OF MANY YEARS**

Subjects are asked, during their 15 seconds of viewing, to count the number of times the letter "F" appears. In any group, most people will guess three. Others will guess four or five. Very few will answer with the correct number, which is six.

The above test shows that the human is not a good inspector. The problem here is a basic one in cognitive psychology. Apparently, since humans pronounce "OF" as "OV," the "F" is frequently missed. The human serves as an information processor and, in this case, tends to distort the information. In any event, the monitoring and inspection process certainly is subject to error.

Vigilance performance inevitably shows a decrement through time. In one study involving a 48-minute vigil, probability of detection dropped from just below 80 percent in the initial stages to approximately 60 percent at the conclusion. This illustrates the rather dramatic decrease in performance effectiveness that can occur for a pure vigilance task.

The same study measured performance of subjects on two consecutive days. No significant difference was found. There was no evidence of a practice effect on the vigilance task. This is not to say that subjects cannot be trained for vigilance, but practice alone is not sufficient. In other studies, subjects have been run for many days and, as here, no practice effect has been found.

Another feature of vigilant performance concerns the signal/rate effect. In another study, again conducted for 48 minutes, subjects saw either 16, 32, or 48 signals occur during that period.

There was a dramatic increase in the rate of detection of these events as a function of whether 16, 32, or 48 signal events were produced during the test period. The more frequently a signal occurs, the higher the probability of detection for any given signal. If you have low probability of the appearance of a signal event, then you will have low probability of detecting that event when it does occur. This clearly has implications for aircraft inspection. Rare faults will be most difficult to detect.

All of the above factors can operate to produce vigilance decrement. The dynamics of vigilance, and vigilance decrement, can be illustrated by an experiment in which adaptive training was used. As a subject's performance improved, the task was made more difficult in proportion. As performance then decreased, the task was made easier. The object's was to produce a constant level of performance. In this study, by continuing to adjust task difficulty, an essentially constant target detection rate of 75 percent was achieved. In terms of aircraft maintenance, this means that if you want a constant detection rate in an inspection task, over a period of time the flaws would have to become larger and larger to be detected at a constant rate.

Figure 1 shows some of the forces impinging on the human inspector which might be viewed as opportunities for management intervention in any program to increase detection probabilities. At the top we see a block containing specifications, photographs, standards, training, and past experience of the operator. These are the variables which directly affect the judgement of the inspector. When an inspector looks at a rivet on an airplane or a pattern appearing on an eddy current scope, he is comparing what he sees to a stored experience. Experience and training can be manipulated to improve performance.

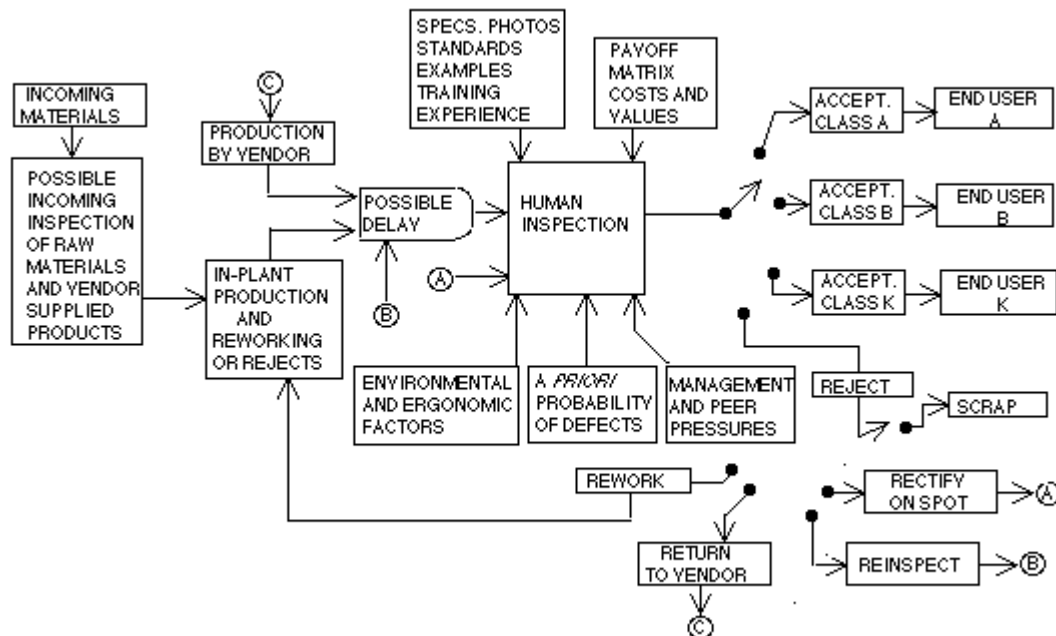

Figure 1 Production, inspection and disposition of items with K acceptance categories (classifications) and one rejection category. Upon rejection, numerous courses of action are available. (From Weiner, 1984).

In studying inspection performance, the consequences, or payoffs, of inspection decisions should be considered. **Figure 2** shows the case in which inspection decisions can be classified in a 2x2 matrix. While some industrial processes call for a 2xn matrix, the 2x2 appears most appropriate for aviation inspection. In Figure 2, there are only two classes in which each event can be categorized. There also are only two response opportunities on the part of an inspector. He can either accept or reject an item. If he accepts an effective item, he has made a correct decision. Likewise, if rejects a defective item, he is correct.

<u>Inspector Decision</u>	<u>State of Product</u>	
	<u>Effective</u>	<u>Defective</u>
Accept	Correct	Type 2 Error Omissive Error
Reject	Type 1 Error Commissive Error	Correct

Figure 2 Categorization of inspector decisions

Now let us examine the incorrect decisions, as shown in **Figure 2**. These are the Type 1 and Type 2 errors mentioned in **Dr. Drury's paper**. If the product is effective and the decision is made to reject, the inspector has made a Type 1 error - a commissive error. This has a value or cost, here referred to as VRE - the value of rejecting an effective product. In aviation, these are the unnecessary removals of aircraft parts or unnecessary redrilling of rivets.

If the item is defective, and the inspector fails to detect it, he has made a Type 2 error - an omissive error. This also has an attached cost or value. In aviation, these are the errors of considerable consequence. This is where a defective part goes undetected and remains in the aircraft. The ultimate consequences can be quite costly.

In one instance, a company producing a medical product considered the cost of Type 2 errors (missing a defective product) to be so high that the inspection process was adjusted to make such an error almost impossible. However, the adjustment greatly increased Type 1 errors. They now are rejecting 50 percent of all products. One-half of everything manufactured is thrown away prior to use. For them, this cost tradeoff appears appropriate.

In another study of inspector performance, more rational results were obtained. In this study, 39 inspectors each examined 1,000 solder connections into which 20 defects had been inserted. There were thus a total of 39,000 inspections conducted. **Table 1** shows that of the 780 defective parts, 646 were correctly rejected. On this basis, the success rate was 83 percent. For the 38,220 effective components, 25 were falsely rejected. We see the probability of false rejection to be less than one in one-thousand. This is excellent inspection performance.

**TABLE 1
RESULTS OF AN INSPECTION OF 39,000 PARTS SHOWING
TYPE 1 AND TYPE 2 ERRORS**

Inspector's Action	Defective	Effective	Total
Accept	134 (Type 2)	38,195	38,329
Reject	646	25 (Type 1)	671
Total	780	38,220	39,000

Data from Jacobson (1952)

In summary, what is known about human vigilance? Man is a poor monitor. Where vigilance is required over time, a vigilance decrement is almost inevitable. Man starts off as an imperfect monitor and the situation only gets worse.

There is a signal rate effect on vigilance. If the rate of appearance of a signal is low, the probability of detecting it is lowered. In aviation this means that the higher the quality of the product, the lower the signal event rate, and therefore the lower the probability of detection of a fault.

Selection of individuals to perform monitoring tasks does not work well. Selection by categories particularly is ineffective. Men versus women or old versus young are not good variables in determining who makes a good inspector.

Training, if well structured, can make a difference in vigilance performance. Practice alone, however, is not effective. The practice must take place within a well defined training effort.

Finally, let me review briefly the available intervention strategies and indicate for each what I consider the probability of producing improvement with that strategy. These are:

Job Redesign = High. Here we can consider such matters as conspicuity of the signal; increasing the signal-to-noise ratio, if possible; length of inspection periods; social atmosphere and the general work environment; and feed-forward and feed-back mechanisms which are providing information to the inspector both before and after performance.

Training = High. Any improvements which can be introduced for the workforce or for the promise of performance benefits.

Selection = Poor. There is little probability of significant payoff here.

In all of the above, there is of course no magic solution. No single step will result in a dramatic improvement in vigilance or maintenance performance. However, appropriate application of known human factors principles, with continuing review of the problems encountered, should result in a steady and definable improvement.

References

Jacobson, H.J. A study of inspector accuracy. Industrial Quality Control, 1952, 9, 16-25.

Weiner, E.L. Vigilance and inspection. In J.S. Warm (Ed), Sustained attention in human performance. New York: John Wiley & Sons Ltd., 1984.

Human Performance Issues in Nondestructive Testing

*Douglas H. Harris, Ph. D.
Chairman
Anacapa Sciences, Inc.*

Human performance plays a vital role in all inspection and tests. In some cases such as visual inspections, the importance of human performance is obvious. But even when technically sophisticated equipment is employed, the outcome is highly dependent on human control actions, observations, analyses, and interpretations. The primary consequences of inadequate performance are missed defects and false reports; and the costs that accompany these errors.

Human-Performance Framework

A variety of techniques are available for the inspection of aircraft engine and airframe structures. Visual, eddy-current, ultrasonic, radiographic, magnetic particle, and penetrate testing methods are used (Hagemaijer, 1988). However, the types of human actions and the sequence in which these actions are performed are comparable among these various techniques. The typical sequence of actions is shown in **Figure 1**.

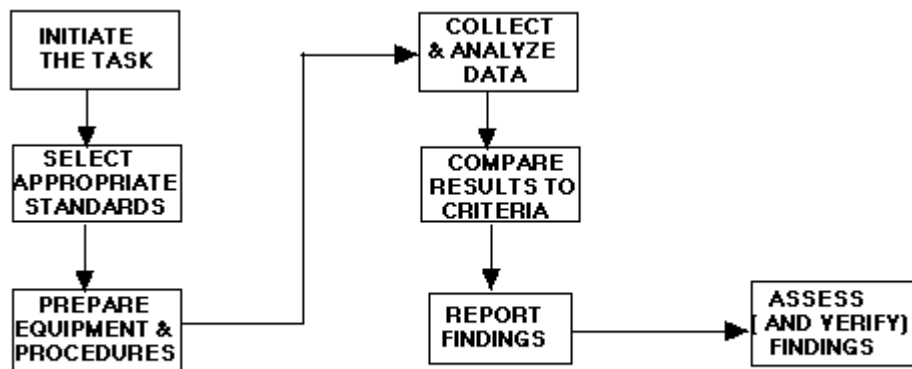

Figure 1 Types of actions and typical action sequence for inspections and tests.

The model illustrated in **Figure 2** shows the relationships that exist among the various factors that can influence human performance in conducting any task or action required for the successful completion of an inspection or test. As shown, any action will always require the input of information through one or more sensory channel (visual, auditory, tactile, etc.) to produce a required outcome. Poor performance often occurs with tasks that do not provide an

adequate match between information input and action output. For example, information that is incomplete, not timely, ambiguous, or irrelevant will lead to incorrect or delayed actions. Information presented in a form not compatible with the mode of the action can also lead to inadequate performance.

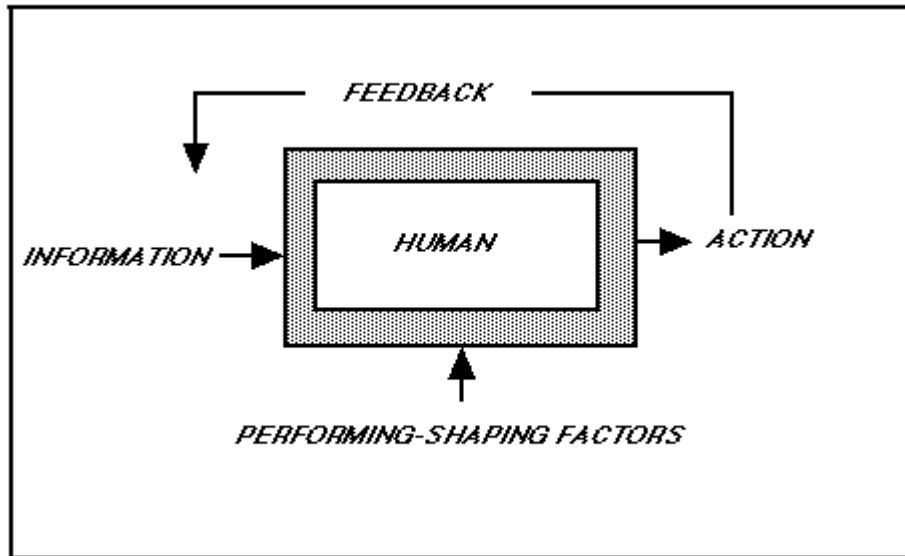

Figure 2 Model of human performance.

To attain and maintain satisfactory levels of performance, feedback is needed on the outcomes of actions taken. Feedback must be complete, relevant, and timely to be effective. However, feedback requirements are highly dependent on the nature of the task or action. For example, feedback of the result of pressing a button during the calibration of an ultrasonic tester must be nearly instantaneous and must be provided each time the button is pressed. On the other hand, feedback on the accuracy of flaw characterization might be effective even if delayed in time and not provided after each characterization.

The information-action-feedback loop is dictated by the design of the equipment and procedures employed in the inspection or test. Consequently, improvement of human performance by addressing inadequacies in this loop must necessarily lead to design changes in equipment and procedures.

The final category illustrated in **Figure 2**, performance-shaping factors, are those influences that are outside the information-action-feedback loop of the task. They include the following:

- Environmental conditions
- Communications
- Time effects (vigilance, fatigue, stress)
- Organizational structure and support
- Knowledge and skills
- Personal work habits and attitudes

The actions shown in **Figure 1** can be combined in a matrix with the human-performance factors

shown in **Figure 2** to provide a framework for addressing human performance issues in inspection and testing. The resulting framework, provided in **Figure 3**, suggests that each of four types of performance factors can be examined for each of the seven inspection or test actions.

<i>PERFORMANCE FACTORS</i>	<i>INSPECTION AND TEST ACTIONS</i>						
	<i>INITIATE</i>	<i>SELECT STDS</i>	<i>PREPARE</i>	<i>COLLECT</i>	<i>COMPARE</i>	<i>REPORT</i>	<i>ASSESS/VERIFY</i>
<i>INFORMATION INPUT</i>							
<i>ACTION OUTPUT</i>							
<i>FEEDBACK</i>							
<i>PERFORMANCE-SHAPING</i>							

Figure 3 Framework of human-performance issues in inspection and testing.

Human Performance Issues in Eddy-Current and Ultrasonic Testing

Human performance issues in eddy-current and ultrasonic testing were studied recently with the framework described above (Harris, 1988). The context of the study was eddy-current and ultrasonic examination of the structural integrity of nuclear power plant components. The inspection technologies examined were similar to those employed in inspections of aircraft structures. Information was obtained from the following types of sources:

- Industry procedural reference documents
- Training materials - coursebooks, guides, worksheets
- Research reports and related documents
- Interviews with subject-matter experts and job incumbents
- First-hand observations of task performance.

The study identified numerous human-performance issues in eddy-current and ultrasonic testing, and produced the following nine recommendations for improving human performance on these types of tests.

Develop Guidelines for Operator-Control Interface Design

In the design of new eddy-current and ultrasonic inspection systems, the application of human-factors principles and techniques has not kept pace with the introduction of new

technology. New, computer-based inspection and testing systems are cumbersome to set up and operate, require excessive manipulation to get the job done, require control actions not logically organized, and rely excessively on human short-term memory. Because a large body of human-factors information now exists to guide the design of human-computer systems, a handbook of selected information should be developed to guide designers of inspection systems. The handbook would contain human-factors principles, data, and techniques specifically applicable to the design of the operator-system control interface for computer-based inspection and testing systems. Application of the handbook could help produce more effective future systems, reducing the time and expense required for performance of inspection tasks.

Analyze Eddy-Current Performance Data

Little information has been generated, to date, on eddy-current testing performance from systematic studies capable of producing scientifically valid, statistically significant results. Consequently, research is needed to answer some very fundamental questions such as the following: For each of the various damage mechanisms encountered, what are the expected rates of alternative inspection outcomes - correct calls, false calls, and missed detections? How is each inspection outcome for each damage mechanism influenced by structure type, geometry, location, and extraneous variables? What is the relative reliability of different cues used for detection and characterization of different types of flaws? Answers to the question posed can point to the specific aspects of eddy-current testing where improvements in system design, inspection strategies and procedures, analyst training and qualification, and inspection organization are likely to have the greatest payoff.

Assess Eddy-Current Information-Integration and Signal Interpretation Strategies

Eddy-current testing requires the analyst to integrate a substantial amount of information to provide the context for signal pattern recognition and interpretation. What is the most effective way to organize and integrate relevant information in support of signal interpretation? What data integration and signal interpretation procedures are most amenable to computer aiding? Alternative data-integration and pattern-recognition strategies and methods should be developed and experimentally evaluated. Alternatives would incorporate applicable human-factors principles (from previous related research) as well as techniques found to be employed by successful inspectors. The research results would identify and define any significant differences among alternative strategies and methods of information integration and signal interpretation, generate the basis for guidelines for more effective eddy-current inspection strategies and methods, and provide criteria for the design of future eddy-current testing systems.

Develop More Effective Eddy-Current Display Designs

The principal displays employed for eddy-current flaw detection and characterization are variations of meter, oscilloscope, and strip-chart type displays. These displays originated with, and have been little changed since, the initial use of analog systems. The geometric forms

(signals) presented on these displays typically do not relate directly to the physical characteristics of what is being inspected, but rather to the characteristics of an induced electric current. Therefore, the information contained in the displayed signals must be mentally transformed by the analyst for purposes of flaw detection and characterization. Such mental transformations are likely sources of inspection errors because they add complexity and ambiguity to the task. They also consume valuable inspection time and effort. The availability of digital signal processing and display technology now provides the opportunity to explore display formats other than those previously dictated by analog technology. Displays that are more representative and directly-interpretable could increase the accuracy of inspections and reduce inspection cost. Costs could be reduced by minimizing inspection time and, with increased accuracy, by reducing the need for redundant inspections and the time required for the resolution of conflicting results.

Research Automatic Eddy-Current Signal Screening and Analysis

Recently, systems have been developed and employed for the automatic screening of eddy-current data by means of computers equipped with detection-rule based programs. The systems are designed to screen the data for signals of potential flaws which are, then, analyzed by an experienced analyst. Research and development work is also being conducted on computer-based systems designed to both detect and characterize flaws. Automatic screening and analysis raise some sensitive human-factors issues: What guideline and techniques are required to assure that the screening criteria selected will produce the desired results? What is the most effective form of interaction among analyst and stem? What steps will be required to gain acceptance for the system, among those who have the ultimate decision-making authority for structural integrity? A human-factors study effort should address the above questions in parallel and in close coordination with system research and development efforts. The effort would be mainly analytical, reviewing and applying appropriate data and principles to answer the issues raised. The answers obtained would help assure the success of increased levels of automation in eddy-current inspection systems.

Collect and Analyze Ultrasonic Performance Data

Round-robin studies of ultrasonic inspections, in which each of a sample of inspectors inspects each of a sample of welds, have shown that inspection accuracy is typically much lower than expected. However, these studies have produced little insight into who inspection accuracy is no better than it is, or specifically what might be done to redesign the task or instrumentation to produce better results. Specifically, answers are required to the following questions: What task and procedural variables correlate, positively and negatively, with inspection accuracy? What signal-interpretation strategies are most successful? What signal-interpretation strategies are most successful? What logical steps are correlated with the different inspection outcomes - correct call, false report, missed flaw - for different flaw types? Performance data should be collected and analyzed to answer these types of questions. Results could identify improvements required in inspection procedures, instrumentation, and training.

Reduce the Complexity of Manual Ultrasonic Detection of IGSCC

A substantial amount of evidence suggests that ultrasonic detection of intergranular stress-corrosion cracking (IGSCC) by manual methods, as the task is presently designed and under the conditions in which the task is typically performed, is too complex to produce reliable results. IGSCC is the type of cracking that results from the continuing effects of structural stress combined with the corrosive effects of environmental elements, and is often referred to simply as "metal fatigue." The research question is how to increase the accuracy and reliability of ultrasonic inspection by reducing the burden and complexity of the task. Preliminary analyses and observations suggest that, although a major breakthrough is not likely, the cumulative effect of many small changes in task design - instrumentation and procedures - should be developed through detailed task analysis and application of human-factors design principles. The recent availability of microprocessor technology for ultrasonic inspection, in particular, provides new opportunities for increasing the compatibility between inspector capabilities and task design.

Define Optimal Strategies for Ultrasonic Testing

There appears to be no single, agreed-upon, best strategy (or strategies) currently employed for the ultrasonic detection and discrimination of flaws. A relatively large number of possible overall strategies exist because many options are available to select from - inspection parameter, inspection techniques, scanning patterns, discrimination logic, and others. For any type of application, a model strategy should be constructed from the collective experience and judgment of a sample of senior, experienced inspectors. The model would specify the analytical sequences used, the emphasis to be given to different variables, the techniques and cues to be employed, and the reasons for each. Inspector trainees could then be provided an optimal strategy, based on the collective insights and experience of senior inspectors, as part of their instruction in the ultrasonic inspection. As a consequence, they could more quickly attain the confidence and proficiency required for this difficult task.

Assess Human-Factors Issues in Enhanced Automated Scanning and Data Recording for Ultrasonic Testing

The development and employment of automated scanning and data recording techniques have overcome important performance problems in some applications of ultrasonic inspection. However, management resistance to automated scanning and recording exists because these methods are often perceived to require more time and money than manual methods. As a consequence, future research and development efforts will undoubtedly be directed toward increasing the efficiency of scanning and reducing the costs of inspections, raising new issues related to the human-system interface. Research on these issues should be conducted in parallel with, and in close liaison with, research conducted in support of the development of advanced ultrasonic inspection systems. Addressing human-factors issues during the development process will assure that advanced ultrasonic inspection systems produce accurate, reliable, and efficient inspector performance. As has been demonstrated in many successful system development

efforts, these issues are best addressed as an integral part of the design effort.

Develop Methods of Sustaining the Effectiveness of Ultrasonic Testing Performance

One of the most powerful factors to influence performance on any task is feedback - information provided to the performer of a task about the effectiveness of task performance. Ultrasonic inspection presents a particularly difficult feedback problem because information needed for feedback is typically not available. For example, if a crack is missed, the error might not be discovered until a later inspection or a structural failure occurs. At that time, even if the information finds its way back, the inspector who missed the defect may be long gone. Moreover, some inspection outcomes receive more attention than others and thus add potential bias to the process. For example, any reported defect (whether correct or not). In spite of the inherent difficulties in providing feedback on this task, are there cost-effective innovations that can be introduced to take better advantage of this powerful means of sustaining accurate inspection performance? If feedback cannot be enhanced in a practical manner, are there other approaches that can be substituted? One possibility is application of the concept of feed-forward, analogous to procedures employed in the calibration of equipment, for fine-tuning an inspector's detection and discrimination skills prior to a series of inspections. Alternative feedback and feedforward techniques for sustaining effective ultrasonic inspection performance should be developed and evaluated.

Conclusion

Eddy-current and ultrasonic inspections are two of the principal techniques available for the nondestructive examination of aircraft engine and airframe structures. Although each of these techniques can be applied by means of technically sophisticated equipment, inspection results are highly dependent on human control actions, observations, analyses, and interpretations. Consequently, substantial potential payoff in the cost-effectiveness of the application of these techniques to aircraft inspections can be realized through improvements in human performance. This paper identified nine human performance issues in eddy-current and ultrasonic inspection, and provided a recommended approach to addressing each of them.

References

- Hagemaijer, Donald J. Cost benefits of nondestructive testing in aircraft maintenance. Materials Evaluation, September 1988, 46, 1272-1284.
- Harris, Douglas H. Human performance in nondestructive inspections and functional tests (EPRI Report NP-6052). Palo Alto, California: Electric Power Research Institute, October 1988.

Appendix B: Meeting Agenda

Human Factors Issues in Aircraft Maintenance and Inspection

12 - 13 October 1988
Old Colony Inn
FEDERAL AVIATION ADMINISTRATION
Washington, D.C.

Wednesday, 12 October 1988

Ballroom A

7:30 a.m. Registration

INTRODUCTION/ORIENTATION

8:30 a.m. Meeting Welcome *Anthony J. Broderick* **Federal Aviation Administration**

Meeting Background and Objectives *William T. Shepherd, Ph.D* **Federal Aviation Administration**

Aircraft Maintenance Parameters *James F. Parker, Jr., Ph.D.* **BioTechnology, Inc.**

FAA Regulatory Requirements for Aircraft Maintenance and Inspection *Raymond E. Ramakis* **Federal Aviation Administration**

10:00 a.m. Break

THE PROBLEM

10:15 a.m. Maintenance and Inspection Issues in Aircraft Accidents/Incidents *Barry Trotter* **National Transportation Safety Board**

James W. Danaher

National Transportation Safety Board

Day-to-Day Problems in Air Carrier Maintenance and Inspection Operations *Robert Lutzinger* **United Airlines**

12:00 noon Lunch Martin Room

MANUFACTURER PERSPECTIVE

1:00 p.m. Maintenance and Inspection from the Manufacturer's Point of View *Robert Oldani* **Boeing Commercial Airplanes**

Human Performance in Aircraft Maintenance: The Role of Aircraft Design *Anthony Majoros, Ph.D.* **Douglas Aircraft Company**

Wednesday, 12 October 1988 - Continued

Ballroom A

2:30 p.m. Break

INDUSTRY PERSPECTIVE

2:45 p.m. Maintenance and Inspection Issues in Air Carrier Operations *Robert Doll* **United Airlines**

Computer Air Carrier Maintenance and Inspection *Norman S. Grubb* **Henson Airlines**

Rotorcraft Maintenance and Inspection *James Moran* **Aerospatiale Helicopter Corporation**

MAINTENANCE AND INSPECTION TECHNOLOGY

Nondestructive Inspection Equipment and Procedures *George Ansley* **Boeing Commercial Airplanes**

5:00 p.m. Adjourn

5:00 p.m.-7:00 p.m. Reception - Martin Room

Thursday, 13 October 1988

Ballroom A

MAINTENANCE AND INSPECTION TECHNOLOGY

8:30 a.m. Improved Information for Maintenance Personnel *Robert C. Johnson* **USAF Human Resources Laboratory**

TRAINING ISSUES

Strength and Problems in Maintenance Training Programs *Richard Hlavenka* **Tarrant County Junior College**

10:00 a.m. Break

Thursday, 13 October 1988 - Continued

Ballroom A

HUMAN FACTORS TECHNOLOGY

10:15 a.m. The Human Operator as an Inspector: Aided and Unaided *Colin G. Drury, Ph.D.* **SUNY, Buffalo**

Vigilance and Inspection Performance *Earl L. Wiener, Ph.D.* **University of Miami**

11:45 a.m. Lunch (On Own)

1:15 p.m. Human Performance in Non-Destructive Inspection Processes *Douglas H. Harris, Ph.D.* **Anacapa Sciences, Inc.**

2:00 p.m. Break

SUMMARY SESSION

2:15 p.m. Development of Summary Statements and Recommendations

4:30 p.m. Adjourn

Appendix C: Meeting Attendees

First Federal Aviation Administration Meeting on Human Factors Issues in Aircraft Maintenance and Inspection October 1989

MEETING ATTENDEES

Allen, Robert, Manager, Continued Airworthiness Staff Federal Aviation Administration, Washington, DC 20591

Ansley, George, **NDT** Specialist, Service Engineering Department Boeing Company, Seattle, WA 98124

Austin, Frank H., Jr., M.D., Human Factors Specialist Federal Aviation Administration, Washington, DC 20591

Baer, Judith, Editor, Ops Update Helicopter Association International, Alexandria, VA 22314

Broderick, Anthony J., Associate Administrator for Regulation and Certification Federal Aviation Administration, Washington, DC 20591

Christensen, Diane G., General Manager BioTechnology, Inc., Falls Church, VA 22042

Cook, Robert D., Assistant Manager, Accident Investigation Federal Aviation Administration, Washington, DC 20591

Danaher, James W., Chief, Human Performance Division National Transportation Safety Board, Washington, DC 20594

Doll, Robert, Vice President of Technical Services United Airlines, San Francisco, CA 94128

Drury, Colin G., Ph.D., Professor of Industrial Engineering SUNY Buffalo, Amherst, NY 14260

Easton, Locke, Aerospace Engineer Federal Aviation Administration, Burlington, MA 01803

Grubb, Norman S., Vice President, Maintenance and Engineering Henson Airlines, Salisbury, MD 21801

Harris, Douglas H., Ph.D., Chairman Anacapa Sciences, Inc., Santa Clara, UT 84765

Hawkins, Joseph, Technical Assistant to the Executive Director for Regulatory Standards and Compliance Federal Aviation Administration, Washington, DC 20591

Hendricks, William R. Director, Accident Investigations Federal Aviation Administration, Washington, DC 20591

Hlavenka, Richard P., Chairman and Associate Professor Division of Aeronautical and Industrial

Technology Tarrant County Junior College, Fort Worth, TX 76179

Johnson, Robert C., Chief, Combat Logistics Branch Air Force Human Resources Laboratory, Wright-Patterson Air Force Base, OH 45433

Kacerguis, Peter, Special Assistant to the Associate Administration for Regulation and Certification Federal Aviation Administration, Washington, DC 20591

Lotterer, Dave, Director, Airworthiness Air Transport Association, Washington, DC 20006

Lutzinger, Robert T., Manager, Aircraft Inspection Department United Airlines, San Francisco, CA 94128

MacIntosh, Robert, Air Safety Investigator National Transportation Safety Board, Washington, DC 20594

Madayag, A. James, Aircraft Certification Specialist Federal Aviation Administration, Kansas City, MO 64106

Majoros, Anthony E., Engineer Scientist Douglas Aircraft Company, Long Beach, CA 90846

McConkey, Edwin D., Manager, Helicopter Programs Systems Control Technology, Inc., Arlington, VA 22209

Mears, Allen, Director of Special Projects Flight Safety Foundation, Arlington, VA 22204

Melton, Carl, Consultant to the Federal Aviation Administration, Norman, OK 73072

Moran, James, Air Safety Investigator Aerospatiale Helicopter Corporation, Grand Prairie, TX 75053

Nightingale, Laura, Recording Secretary BioTechnology, Inc., Falls Church, VA 22042

Oldani, Robert L., Manager, Maintenance and Ground Operations Boeing Commercial Airplanes, Seattle, WA 98124

Palmerton, William, Aviation Safety Inspector Federal Aviation Administration, Kansas City, MO 64106

Parker, James F., Ph.D., President BioTechnology, Inc., Falls Church, VA 22042

Pickrel, Evan, Consultant to the Federal Aviation Administration, Alexandria, VA 22309

Ramakias, Raymond, Manager, Aircraft Maintenance Division Federal Aviation Administration, Washington, DC 20591

Rohrbach, Peter, Professional Aircraft Mechanics Association, Potomac, MD 20850

Shepherd, William T., Ph.D., Acting Manager, Biomedical and Behavioral Sciences Division Federal Aviation Administration, Washington, DC 20591

Siegman, James, Air Safety Inspector Federal Aviation Administration, Washington, DC 20591

Thackray, Richard, Ph.D., Research Psychologist Civil Aeromedical Institute Federal Aviation Administration, Oklahoma City, OK 73125

Trotter, Barry, Air Safety Investigator National Transportation Safety Board, Washington, DC 20594

Watson, Jean, Research Program Assistant Federal Aviation Administration, Washington, DC 20591

Wiener, Earl., Ph.D., Professor, Department of Management Science and Industrial Engineering University of Miami, Coral Gables, FL 33124