

LEVEL

ADA103190

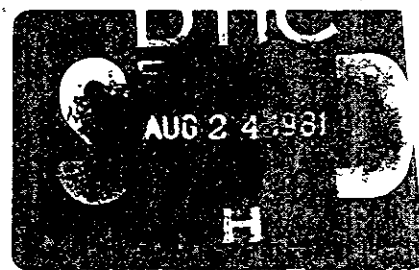

1. Report No. FAA-AM-81-6	2. Government Accession No. AD-A103190	3. Recipient's Catalog No.	
4. Title and Subtitle EFFECT OF DIFFERENT RUNWAY SIZE ON PILOT PERFORMANCE DURING SIMULATED NIGHT LANDING APPROACHES		5. Report Date FEBRUARY 1981	6. Performing Organization Code
7. Author(s) Henry W. Mertens and Mark F. Lewis		8. Performing Organization Report No.	
9. Performing Organization Name and Address FAA Civil Aeromedical Institute P.O. Box 25082 Oklahoma City, Oklahoma 73125		10. Work Unit No. (TRAIS)	11. Contract or Grant No.
12. Sponsoring Agency Name and Address Office of Aviation Medicine Federal Aviation Administration 800 Independence Avenue, S.W. Washington, D.C. 20591		13. Type of Report and Period Covered	
15. Supplementary Notes Work was performed under Task AM-D-79-PSY-67 and AM-A-80/81-PSY-85.		14. Sponsoring Agency Code	
16. Abstract Both anecdotal reports from pilots and theories of visual cues would predict lower approaches to narrow or long runways than to wide or short runways. Practice with a particular width of runway would also be predicted to increase subsequent approach angles flown to wider runways, and decrease approach angles to narrower runways. Two experiments with instrument-rated pilots made quantitative tests of these predictions.  In Experiment I, three pilots flew simulated approaches and landings in a fixed-base simulator with a computer-generated-image visual display. Practice approaches were flown with an 8,000-ft-long runway that was either 75, 150, or 300 ft wide; test approaches were to runways with widths of 75, 100, 150, 200, and 300 ft. In Experiment II, 40 pilots controlled the slant of a moving model runway during simulated night visual approaches. Five different models simulated runways from 100 to 300 ft wide and 3,000 to 9,000 ft long. As predicted, training on a wide runway in Experiment I lowered approach angle in approaches to narrower runways; a narrow practice runway also raised approach angles to wider runways. The magnitude of these practice effects increased as distance from runway threshold decreased. There was also a general tendency for approach angles to decrease as runway width decreased. The latter effect was corroborated in Experiment II; in addition, generated approach angles decreased with increasing runway length. Giving half the pilots information about runway size prior to each approach had no effect on responses. These findings add to the quantitative evidence of danger in night visual approaches due to visual illusions and large variability in the visual perception of approach angle.			
17. Key Words Approach and landing Visual cues Runway image size		18. Distribution Statement Document is available to the public through the National Technical Information Service, Springfield, Virginia 22161	
19. Security Classif. (of this report) Unclassified	20. Security Classif. (of this page) Unclassified	21. No. of Pages 18	22. Price \$5.00

EFFECT OF DIFFERENT RUNWAY SIZE ON PILOT  
PERFORMANCE DURING SIMULATED NIGHT LANDING APPROACHES

Introduction.

Visual illusions are considered to be an important factor in causing a relatively high accident rate during night visual landing approaches (1-5,7-9, 12,13,15,23,24). Analyses of many civilian (11,12,13) and military (22) accidents show that a relatively large number of aircraft crash short of the runway in nighttime accidents unrelated to aircraft malfunction or adverse weather. Many of these crashes are thought to have been caused by a lack of visual information or to "erroneous information" in certain geographical situations (e.g., sloping runway or sloping terrain around the runway) (12). Until recently our knowledge of these visual illusions in the night approach situation has been based, in a large part, on anecdotal accounts by pilots who have survived some crashes. Because of the relatively high accident rate in the night approach situation and the high cost of such accidents in terms of human life, studies were undertaken to assess the alleged visual illusions quantitatively and to determine their cause so that (i) pilots could be given more explicit information concerning the hazards of night landing approaches and (ii) a means of altering the approach environment might be identified so as to effectively improve safety.

Previous research has shown that there is a general tendency for pilots to fly lower approaches at night in "black hole" conditions, in which only the edge and end lights of an unfamiliar runway are available for vertical guidance during the approach, and that the perception of approach angle is extremely variable in this situation (10,17,20,21). This problem of low and variable approaches at night may be the result of large variations in the widths and lengths of runways at various airports. Some researchers have suggested that if the width and/or length of an unfamiliar runway differs radically from that to which the pilot is accustomed, then the resulting illusions cause systematic deviations above or below the desired glidepath (1,7,23). Wulfeck, Weisz, and Raben (26) stated the problem and a theoretical interpretation as follows:

A pilot approaching an unfamiliar airport may have trouble judging position by the shape of the rectangle outlined by runway lights. For example, after a few landings at one airport, he learns the length-to-width ratio for the runway that will show him he is approaching at the proper glide angle. If he goes into a strange airport where the runway is either shorter or wider and attempts to use the same perspective cues as before, he will be too high and come in at too steep an angle. Conversely, if the runway is longer or narrower, he will come in too low. These difficulties are to be expected from the geometry of the situation, and they are confirmed by pilots' experiences, though no experimental data are available. (p. 262).

This present study has been conducted in an attempt to quantify these visual effects, or illusions. Experiment I was designed (i) to evaluate deviations from the desired glidepath in simulated night approaches to unfamiliar runways of the same length but of various widths, and (ii) to determine the effect of practice with a particular runway width on subsequent approaches to runways of different widths. Experiment II was then conducted to compare the effects of varying runway width with the effect of varying runway length. The nighttime "black hole" was simulated in both experiments to provide maximum effect of variations in runway length and width.

## EXPERIMENT I

In the first experiment, an aircraft simulator with a computer-generated visual display of the runway scene was used to measure performance during approaches to runways of constant length but varying width, following practice with a fixed runway width.

Familiarity with a particular runway width was accomplished by having subjects fly 20 simulated visual approaches and landings to a runway that was either 75, 150, or 300 ft wide. The effect of practice was then measured in 20 additional approaches in which five runway widths (75, 100, 150, 200, and 300 ft) were presented in random order. The theory of Wulfeck et al. would predict that approaches flown to runways of differing width but constant length would generate increasingly larger approach angles as a direct function of greater runway width. Additionally, the function relating runway width to approach angle should (i) shift upward following practice (familiarity) with the most narrow (75 ft) runway and (ii) shift downward after practice with the widest (300 ft) runway. The function should have an intermediate position between the two previous cases when practice is given with a runway of intermediate (150 ft) width. That is, approach angles should shift upward for widths greater than that of the practice runway and downward for test widths narrower than practice.

### Method.

Subjects. Three men, pilots with instrument and multiengine ratings, served as subjects. All had at least 20/20 acuity at the 30- and 40-inch distances measured by a test developed at the Civil Aeromedical Institute, and all passed the Farnsworth Lantern Test for color vision. The three subjects had experience levels of 300, 4,200, and 7,000 hours of flying time.

Apparatus. The subjects flew simulated Visual Flight Rules (VFR) approaches in a fixed-base simulator comprising a specially modified Analog Training Computer, Model 610-J simulator, with a computer-generated image (CGI) visual display mounted in the cockpit windshield to provide a simulation of the out-the-windshield visual scene synchronized with the simulated aircraft's flight. The simulator was modified to produce electrical signals corresponding to the following parameters of flight: (i) X and Y coordinates, locating the aircraft on the ground plane to the nearest 3 ft, (ii) altitude coordinates to the nearest foot, (iii) roll, (iv) pitch, and (v) heading. The CGI system has been described elsewhere (18). A 17-inch multicolor cathode-ray tube was

Accession For	
NTIS STAK	<input type="checkbox"/>
DTIC TAB	<input type="checkbox"/>
Unannounced	
Justification	
By	
Distribution/	
Availability Codes	
Dist	
	CONFIDENTIAL

A

mounted in front of the pilot and ahead of the cockpit windshield, at a distance of 3 ft from the pilot's eye. The display was controlled by a Digital Equipment Corporation PDP-11/45 computer with a VB-11 display processor and associated analog and digital inputs.

The display simulated a dynamic nighttime visual scene synchronized with the maneuvers of the aircraft simulator. Data bases were constructed to simulate runways 75, 100, 150, 200, and 300 ft wide. The length of all runways was 8,000 ft and only runway lighting was visible in the out-the-windshield scene which simulated a "black hole" situation (lights simulating approach lighting, taxiways, terminal areas, other runways, etc., were excluded). The intensity of all simulated runway lights varied with distance and had a realistic appearance.

Procedure. In the first experimental session, each subject's acuity and color vision were tested. The subjects were then acquainted with the simulator. Recommended flap settings, airspeeds, and vertical speeds to be used were discussed at that time. Thirty to forty preliminary flights were then made to let each subject become familiar with the simulator before the experimental runs were begun. Each flight in both preliminary and experimental trials consisted of takeoff and climb to a designated altitude on a constant heading. When the subject had established level flight at the designated altitude and proper heading, the simulated position of the aircraft was moved by computer command to a position approximately 5 1/2 to 6 1/2 miles from threshold on the extended centerline of the runway. The designated altitude assigned for each approach was randomly selected from a table ranging from 1,100 to 2,700 ft in 100-ft steps. Although the subject always knew the altitude from which the approach was started, he was not informed of the distance from the runway at the beginning of the approach. The task of the subject during both preliminary training and testing was to fly a "normal" glidepath angle during the approach and to touch down about 1,000 ft upwind from the runway threshold.

There were three conditions of the experiment in which each subject participated. Each condition consisted of four experimental sessions with one session per day. These four sessions were divided into two familiarization (practice) sessions and two test sessions. Three runway widths (75, 150, and 300 ft) comprised the three conditions used during the practice sessions. In each condition, the two practice sessions comprised 20 approaches (10 per session) to the appropriate practice runway. The two practice sessions were followed by two test sessions in which approaches were made to runways of five widths: 75, 100, 150, 200, and 300 ft.

The 10 test approaches in each test session consisted of two blocks of five approaches with all five widths given in a different random order in each block. Therefore, following practice approaches in a particular condition, each subject made a total of four test approaches to each of the five test runway widths. It should be noted that in preliminary trials, which were given to acquaint subjects with the simulator prior to the first experimental practice and test sessions, the width given each subject corresponded to the runway width administered during the practice sessions of the first experimental condition.

The order in which the three experimental conditions (practice runway widths) were given was different for each subject. The three orders were: Subject 1-75, 300, 150 ft; subject 2-150, 75, 300 ft; subject 3-300, 150, 75 ft.

Results.

In each test trial, simulated altitude and distance of the aircraft were recorded at 1-second intervals during the approaches. These data were then converted to generated approach angles (calculated by finding the angle whose tangent was the ratio of generated altitude to distance from the desired touchdown point, 1,000 ft upwind from threshold).

Means of the approach angles (in degrees) as a function of practice runway width, test runway width, and distance, were evaluated by analysis of variance. Distance was evaluated in this analysis by obtaining the mean approach angle in each of the four 1-nmi segments of each approach over the range of distances from 4-nmi (24,000 ft) to threshold. The significant effects in this analysis were the main effects of practice runway width ( $p < .05$ ) and

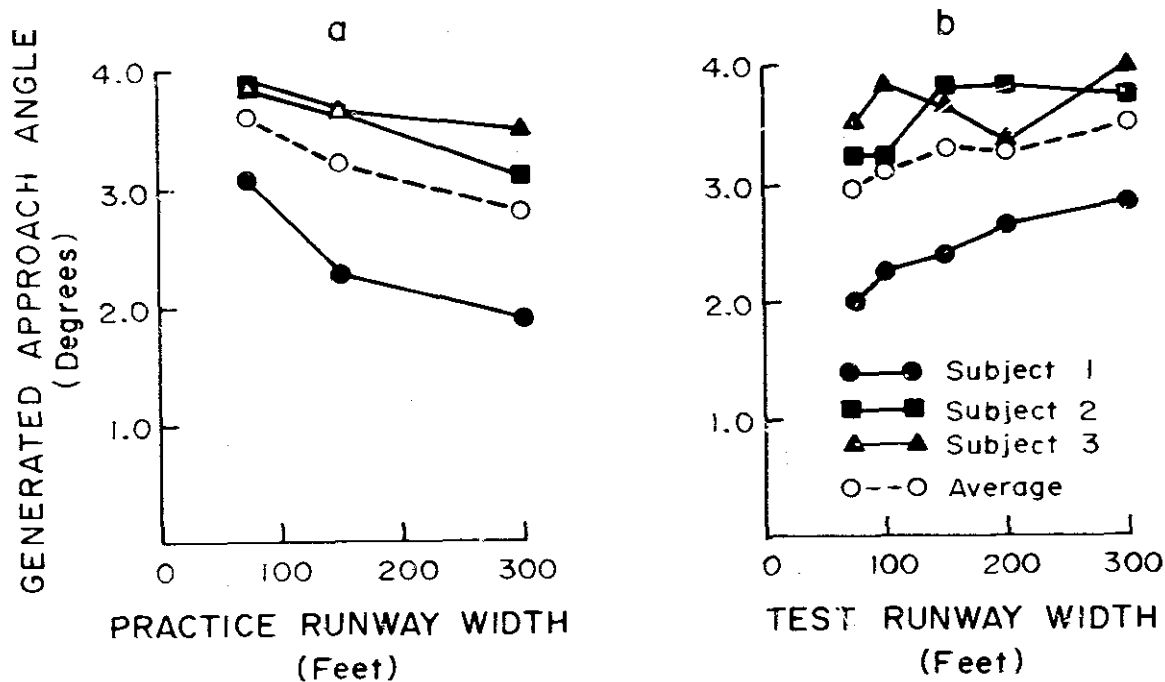

Figure 1. The main effects of (A) practice and (B) test runway width on generated approach angle in individual subjects.

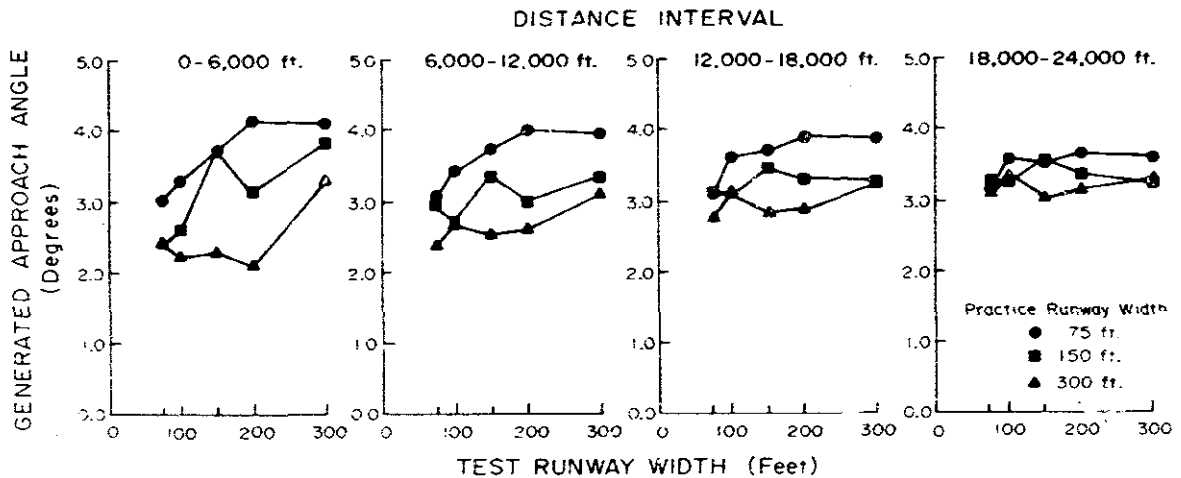

Figure 2. The effect of practice and test runway width in each of the four 1-nmi segments of approaches from 24,000 ft to threshold.

the interactions of both practice runway width with distance ( $p < .01$ ) and test runway width with distance ( $p < .01$ ). Figure 1A shows the significant main effect of practice runway width for each subject as well as for data averaged over subjects. Mean approach angles generated by pilots decreased as a function of practice runway width for all subjects. The effect of test runway width is shown in Figure 1B. Although the average over subjects indicates an increase in mean approach angle with test runway width, the curves for the individual subjects show that this trend was consistent for only one subject.

The significant interactions of practice and test runway width with distance are shown in Figure 2, where mean approach angles are plotted as a function of practice and test runway width separately for each of the four 1-nmi distance intervals between 24,000 ft and threshold. Figure 2 shows that the trends in the main effects of both practice and test runway width are generated at the nearest distance interval and decrease with distance from runway threshold. Although the main effect of test runway width was not consistent in the three subjects when data were averaged over all distances, a large effect of test runway width is apparent at the nearest distance interval. To evaluate the consistency of that result in the data for individual subjects, the interaction of practice and test runway width in the distance interval from 6,000 ft to threshold was plotted in Figure 3 for each subject. These data show a large effect of test runway width, with approach angle increasing as a function of test runway width in the data of subjects 1 and 2. Although the possibility of a similar trend is suggested in the data of subject 3 in the curves for the 75- and 150-ft practice conditions, this subject's data are quite variable and the curve for the 300-ft practice condition clearly does not support this trend. In the latter curve, approach angles generated have a pronounced V-shape; the curve decreases consistently as test runway

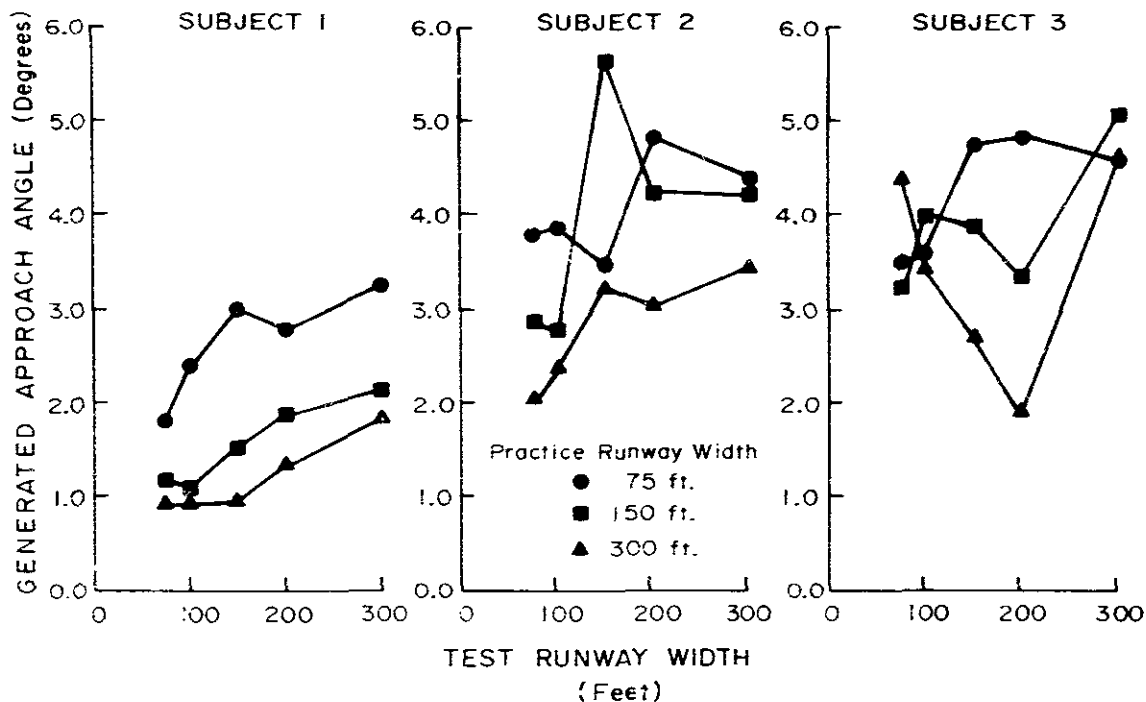

Figure 3. The effect for each subject of practice and test runway width in the last mile of approaches.

width increases up to 200 ft and then increases dramatically. The main effect of practice runway width as shown in Figure 3 is consistent in all three subjects and in accord with theoretical predictions. Agreement with the theory is less clear in the case of the effect of test runway width due to variability in responses, but the predicted increase in approach angle with test runway width is supported by trends in the data at near distances.

Variability within the responses of an individual subject was measured by calculating the range of responses in the four approaches made in a particular experimental condition. Mean intrasubject ranges for each practice runway width, test runway width, and distance are shown in Table 1. These data were not given further statistical analysis. The only variable affecting intrasubject response variation was distance. The intrasubject range of approach angles consistently increased as distance from runway threshold decreased. There was no consistent effect attributable to practice runway width or test runway width. Differences among subjects were also not great. The most important finding was that the range of approach angles was quite large in the last mile of the approach in all three subjects; intrasubject range approached a value of  $3^{\circ}$  in the responses of two subjects.

Variation between subjects in approach angle was measured in terms of the range of individual subject means for each combination of practice runway width, test runway width, and distance interval. These intersubject



TABLE 1. Intrasubject Variability (Range) of Generated Approach Angles  
(in degrees) as a Function of Practice and Test Runway Widths and Distance

<u>Practice Runway</u>	<u>Subject</u>			<u>Mean</u>
	<u>S1</u>	<u>S2</u>	<u>S3</u>	
75 ft	2.26	1.64	1.77	1.89
150	1.49	2.31	1.33	1.71
300	1.13	1.36	1.33	1.27
<u>Test Runway</u>				
75 ft	1.76	1.89	1.26	1.64
100	1.28	1.50	1.27	1.35
150	1.89	1.86	1.91	1.89
200	1.54	1.54	1.46	1.51
300	1.67	2.07	1.49	1.74
<u>Distance Interval</u>				
0 - 1 nmi	1.87	2.71	2.75	2.44
1 - 2	1.66	1.88	1.27	1.60
2 - 3	1.54	1.47	1.05	1.35
3 - 4	1.44	1.01	.84	1.10

variability data are summarized in Table 2. The average intersubject range is given for each practice runway width, test runway width, and distance interval. Again, only distance appears to be systematically related to variability.

#### Discussion.

This experiment was an attempt to quantify a visual illusion in the pilot's perception of vertical position in the night approach situation due to variation in runway width and prior practice with particular runway widths. Anecdotal references to runway width illusions in the aviation literature suggest that perceptual errors in judgments of approach angle as a function

TABLE 2. Intersubject Variability (Range) of Generated Approach Angles  
(in degrees) as a Function of Practice and Test Runway Width and Distance

<u>Practice Runway</u> (ft)	<u>Range</u>
75	1.22
150	1.44
300	1.13
<u>Test Runway</u> (ft)	
75	1.49
100	.86
150	1.37
200	1.10
300	1.49
<u>Distance Interval</u> (nmi)	
0 - 1	1.94
1 - 2	1.16
2 - 3	1.01
3 - 4	0.94

of differences between familiar and strange runways are many and consistent. The present experiment confirmed the consistent effect, in three pilots, of practice with a particular runway on subsequent generated approach angles with runways of differing size. The present finding also indicates that visual experiences with a particular runway over the short term (only 20 practice approaches) are sufficient to bias responses. Thus, "familiarity" with a particular runway size appears to lose its effect as a function of intervening experience with a runway of different size.

Of particular importance to pilots, we believe, was the finding that in the last mile of the approach to a particular runway, the biasing effects of visual experience with a particular (prior) runway of a different width will result in the later approach being flown above or below the desired approach path by as much as one degree or more, on the average. The fact that the variability of approach angles was large, both within the approaches of an individual pilot and among all pilot subjects, does not detract from the importance of the present findings. Rather, it serves to emphasize the fact that the pilot's perception of vertical position is imprecise during visual approaches at night. The pilot's perception of approach angle in repeated approaches in the same environment is, therefore, best described by a distribution of responses in which variability, as well as central tendency, must be considered. The effect of the runway width illusion is to shift the whole

distribution of responses that can occur in a given runway situation up or down the scale of approach angles. In this regard, a low approach and resulting crash short of the runway is most probable in the case when a response in the lower extreme of the distribution occurs and when the pilot's recent prior experience with a wider runway has shifted his response distribution downward. Likewise, a high approach with a probable overshoot of the runway is most likely to occur after recent experience with another more narrow runway.

## EXPERIMENT II

Although Experiment I did not vary the length of the simulated runway, the theory of Wulfeck et al. (26) also predicts that approaches flown to runways of differing length but constant width should generate approach angles that decrease as a direct function of test runway length. This prediction was tested in Experiment II, and the effect of variation in runway width re-examined, again in a simulated nighttime "black hole" situation. The comparison of length and width effects has significance not only in quantifying visual illusions in the night approach to landing situation but also has significance in determining which cues in the runway image are important in the perception of the approach path at night.

A different task, requiring less training of subjects, and a different visual simulation technique were used in Experiment II to study runway size effects. Different lengths (3,000 to 9,000 ft) and widths (100 to 300 ft) of runway lighting systems were simulated with scale models. The task of the pilot was always to control a model, as it moved toward him over the simulated distance range of 23,000 to 5,000 ft from threshold, to produce a "normal" approach angle, and to produce the same "normal" approach angle on all attempts. The effect of prior knowledge of runway size was also studied by giving half the pilots information about runway size prior to each simulated approach.

### Method.

Subjects. Forty male pilots served as subjects. They were between 25 and 60 years of age and were active in air carrier, military, or general aviation. All had 20/20 acuity at the far point, and all possessed instrument ratings. The subjects were randomly assigned to two groups differing in whether they were given runway size information. Twenty subjects in one group were not given runway size information; they had a median experience level of 1,950 total flying hours with a semi-interquartile range of 1,850 hours. The 20 subjects in the group that was given runway size information had a median experience level of 1,750 hours with an interquartile range of 2,615 hours. Nine pilots in the "No Size Information" group and seven pilots in the "Size Information Group" had heavy multiengine aircraft experience. All other subjects flew light single and twin engine aircraft.

Apparatus. The apparatus used in this study has been described in detail previously (18). The nighttime approach scene was simulated with five models of runway lighting systems containing edge and end lights only, with lights colored appropriately. Runway width was varied in three of the models. The simulated widths were 100, 150, and 300 ft, and all three had a simulated

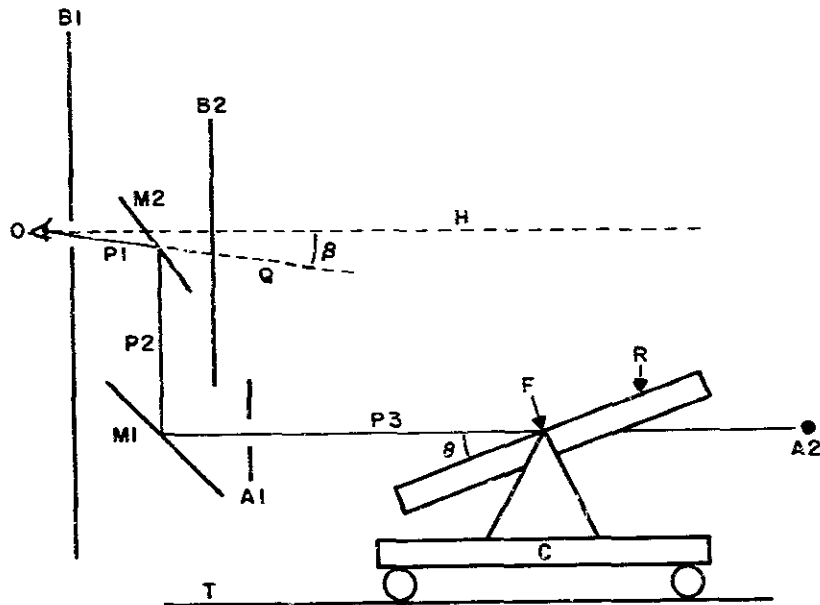

Figure 4. Schematic of apparatus (A1 and A2, removable targets for aligning optical system; B1 and B2, baffles; C, cart; F, rotation axis; H, horizontal line-of-sight; M1 and M2, mirrors; O, eye position; P1, P2, P3, segments of the optical axis; Q, apparent axis of radial motion; R, runway model; T, track; B, viewing angle;  $\theta$ , model slant.

length of 6,000 ft. The two additional models had 150-ft widths, but had lengths of 3,000 and 9,000 ft. Length/width ratios of 20:1, 40:1, and 60:1 were represented in these models. The models were created in 1,200:1 scale using a fiber optic technique described previously (18). The light box on which the models were mounted for experimental trials contained fluorescent sources and intensity was adjusted to simulate an average luminous intensity of 120 candelas for individual white runway lights.

A schematic diagram of the apparatus is shown in Figure 4. It consisted of a runway model (R), the cart and track (C and T) on which the model runway moved toward the subject, and a mirror viewing system (M1 and M2). The model was viewed monocularly from an enclosed observation booth through a 12-mm aperture at B1. This arrangement enabled the model to move directly toward the observation point along a virtual optical path (Q) which was  $3^\circ$  below the straight ahead direction (H). Since the model was seen in an otherwise dark field, variation in the slant of the model ( $\theta$ ) appeared to the subject as a change in approach angle. The slant of the model and, hence, apparent approach angle, was controlled by the subject during the experimental trials. Model slant was measured and recorded to the nearest  $0.1^\circ$  throughout each experimental trial. Targets A1 and A2, shown in Figure 4, were only present during optical alignment of the system.

Procedure. The subject's task was to control the runway model as it moved toward him in order to produce what looked like a "normal" approach angle, and to produce the same angle on every subsequent trial. During each trial, the model was visible and was controlled continuously by the subject as it moved toward the observation position over a simulated distance range of 23,000 ft to 5,000 ft from threshold. The simulated approach speed was a constant 125 knots.

After familiarization, four practice trials were given each subject with the 150-ft-wide, 6,000-ft-long runway. Fifteen test trials with all five runways followed. Prior to the start of each test trial, the model was set at a simulated approach angle of  $0.5^\circ$ ,  $3.0^\circ$ , or  $5.5^\circ$ . Each of the 15 combinations of five runways and three starting angles appeared once in random order in the series of test trials given each subject. In the "Size Information Group," subjects were told the simulated size of the runway prior to each trial. No feedback concerning performance was given any subjects during the experimental period. Experimental sessions lasted approximately 2 hours for each subject.

### Results.

Approach angle was the dependent variable. It was defined as the angle between the line-of-sight to the runway threshold and the plane of the runway model. Approach angles were measured for the present analysis at half-mile (3,000 ft) intervals from 17,000 to 5,000 ft from threshold.

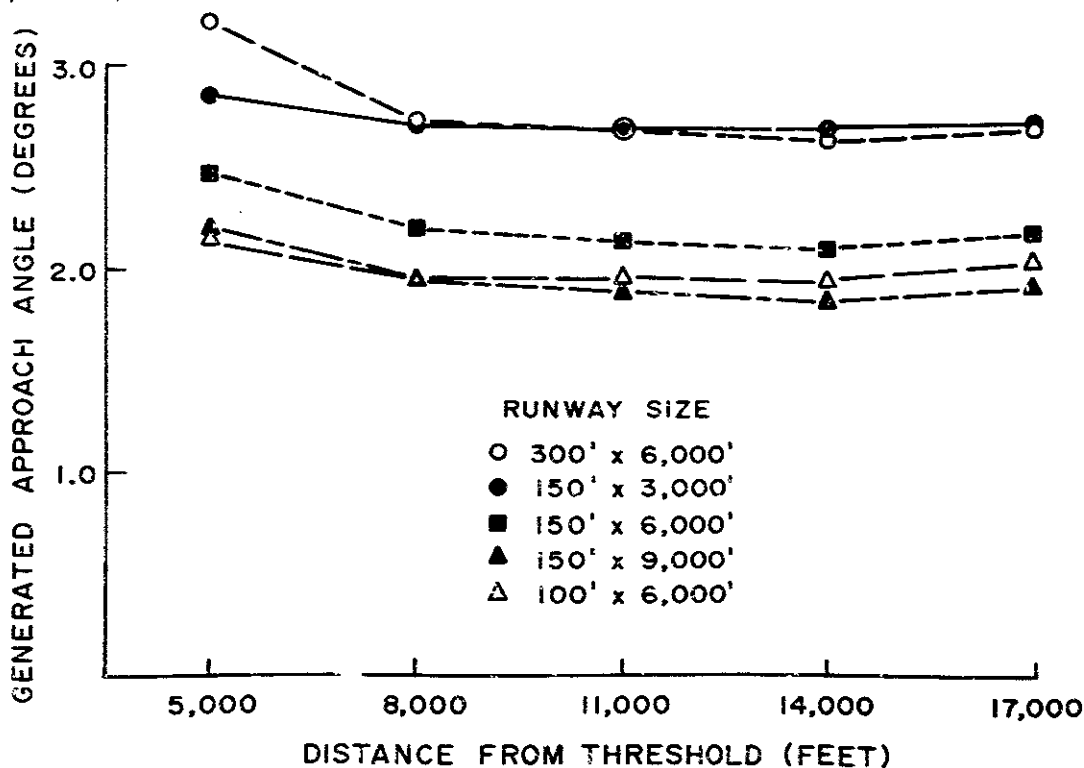

Figure 5. The effect on generated approach angles of runway size and distance from runway threshold.

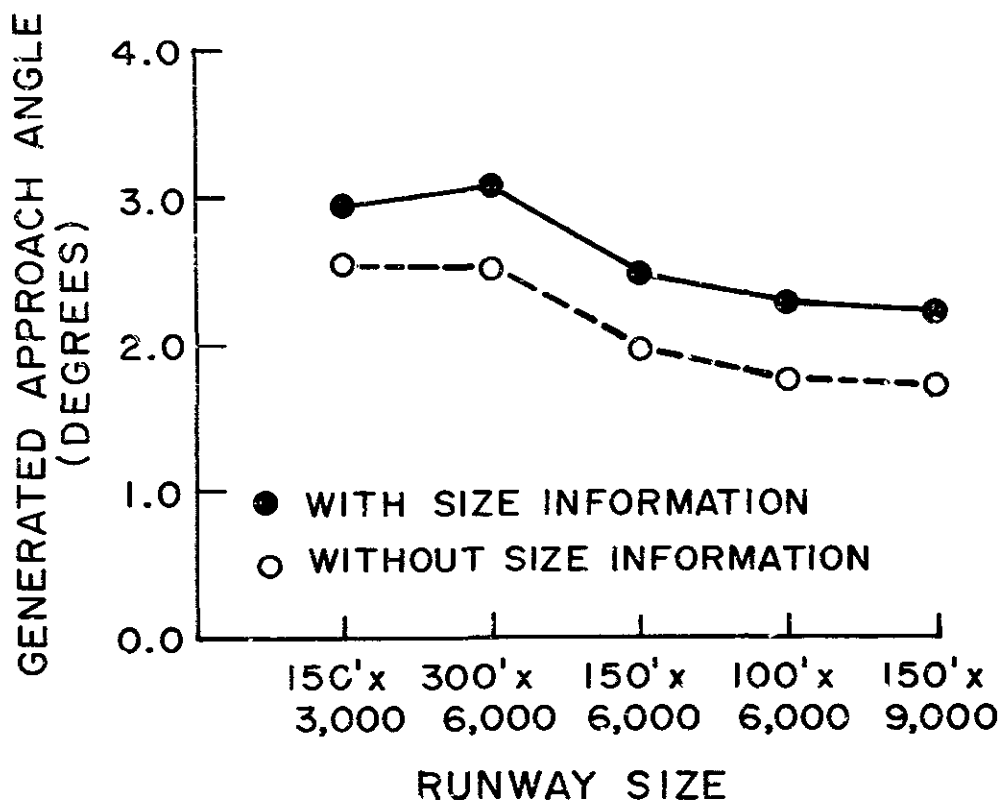

Figure 6. The effect on generated approach angles of verbal size information and actual runway size.

The effects of varying runway size and distance on generated approach angles are illustrated in Figure 5. Both runway size and distance had effects statistically significant at the 0.01 level, as did their interaction. For the three 6,000-ft runways, generated approach angles increased as runway width increased. Mean approach angles for the 300-, 150-, and 100-ft-wide runways were  $2.80^{\circ}$ ,  $2.23^{\circ}$ , and  $2.01^{\circ}$ , respectively. For the three 150-ft-wide runways, approach angles increased as runway length decreased. Mean approach angles for the 3,000-, 6,000-, and 9,000-ft runways were  $2.74^{\circ}$ ,  $2.23^{\circ}$ , and  $1.96^{\circ}$ , respectively. Runways of different sizes, but with identical length/width ratios, produced similar approach angles on the average, and mean approach angle increased as a function of runway length/width ratio. However, when length and width effects for individual subjects were examined, there was no significant correlation found ( $r = 0.05$ ).

The effect of knowledge of runway size is shown in Figure 6. Mean approach angles were approximately  $0.5^{\circ}$  higher in the group given knowledge of runway size prior to each trial, but that effect was not statistically significant. There was also no interaction of knowledge of runway size with variation in simulated runway size in the production of approach angles.

The main effect of starting angle was significant at the .01 level as was its interaction with distance. In general, approach angles increased as a function of starting angle. The difference in mean approach angle between the 5.5° and 0.5° starting angle conditions was 0.78° at the 17,000-ft distance. This difference decreased to 0.25° at the 5,000-ft distance. There was no interaction of starting angle with either simulated runway size or information about runway size.

TABLE 3. Intersubject Range in Degrees as a Function of Runway Size and Distance From Threshold

DISTANCE (FEET)	RUNWAY SIZE (FEET)					MEAN
	150 x 3,000	300 x 6,000	150 x 6,000	100 x 6,000	150 x 9,000	
5,000	4.68	6.55	5.88	4.49	4.56	5.23
8,000	3.90	5.26	4.59	3.79	3.95	4.30
11,000	4.59	4.55	3.85	3.06	3.48	3.91
14,000	4.98	4.14	3.44	3.56	3.43	3.91
17,000	4.51	3.33	3.54	3.33	3.86	3.71
MEAN	4.53	4.77	4.26	3.65	3.86	

TABLE 4. Intrasubject Range in Degrees as a Function of Runway Size and Distance From Threshold

DISTANCE (FEET)	RUNWAY SIZE (FEET)					MEAN
	150 x 3,000	300 x 6,000	150 x 6,000	100 x 6,000	150 x 9,000	
5,000	.90	1.07	.85	.73	.74	.86
8,000	.77	.77	.68	.73	.61	.71
11,000	.79	.87	.73	.72	.56	.73
14,000	.84	.98	.79	.75	.72	.82
17,000	.97	1.02	1.05	.99	.83	.97
MEAN	.85	.94	.82	.78	.69	

An important finding concerns the variability of responses between subjects in a given experimental condition. The average range of responses between subjects (intersubject variability) over all experimental conditions was 4.2°. Intersubject range is shown in Table 3 as a function of runway size and distance. There is a tendency for the intersubject range of responses to vary inversely with both distance and runway length/width ratio.

The range of responses within a given experimental condition was determined for each subject as a measure of intrasubject variability. Intrasubject variability averaged over subjects is shown as a function of runway size and distance in Table 4. In the case of the mean intrasubject range of responses, variability again varies inversely with runway length/width ratio. Intrasubject variability initially decreases with distance, from 17,000 to 11,000 ft. and then increases at the nearest, 5,000 ft., distance. These fluctuations in mean intrasubject range of responses were small, however, on the order of  $0.2^{\circ}$ .

### Discussion.

The present experiment did not permit feedback to the pilots concerning their accuracy of response. Responses were analogous, therefore, to responses to unfamiliar runways of widely varying size. The present study demonstrates the existence of illusions due to variations in both runway length and width in simulated nighttime "black hole" situations. As runway length/width ratio was increased from 20:1 to 60:1, approach angles decreased by  $0.84^{\circ}$ , from  $2.72^{\circ}$  to  $1.96^{\circ}$ , on the average. These findings, and the findings of Experiment I, corroborate warnings of runway size illusions from anecdotal reports of pilots, and have implications regarding which cues in the runway image produce the illusions.

There are at least three cues involving runway image size and shape which permit prediction of effects of varying runway width and length on pilot judgment of approach angle. These are (i) linear perspective, (ii) runway image height, and (iii) length/width ratio in the runway image. Linear perspective can be defined as the magnitude of the base angles of the trapezoidal runway image when the pilot's eye is aligned with the extended centerline. Linear perspective increases with approach angle and distance, and varies inversely with runway width. The linear perspective cue may predict an effect of width if the pilot's perceptual system utilizes the natural relation between linear perspective and distance learned for a particular (familiar) runway and the normal approach angle. Applying such a learned function to a wider runway would cause the pilot to produce a higher than normal approach angle, and a narrower runway would cause low approaches. This cue system would predict runway width effects, but would not predict the effects of varying runway length observed in the present experiment.

The second cue, runway image height, increases with approach angle and runway length, and decreases with distance from the runway. Applying a learned relation of image height to distance would cause high approaches with shorter than normal runways and low approaches with longer than normal runways. The image height cue will predict runway length effects, but will not predict the effect of varying runway width that was observed in this study.

A third cue which will predict runway size effects on perception of approach angle is the ratio of length to width in the runway image (26) described above. It can be shown geometrically, for all runways with the same ratio of actual length to actual width, that the ratio of runway image height to image width of the far end is a function of only one variable,



approach angle (21). The ratio appropriate for a given approach angle increases with actual length/width ratio in the runway, but is independent of absolute dimensions of the runway. Applying a particular learned value of image length/width ratio to runways with actual length/width ratios greater or less than normal will result in a deviation below or above the normal approach angle, respectively. The present finding of both length and width effects is in agreement with predictions of the image length/width cue. The lack of significant correlation between length and width effects, however, suggests the possibility that image height and linear perspective, working independently, may have caused the runway size effects observed. An alternative possibility is that the image length/width cue determined the illusions, but response variability obscured the relation of length and width effects. Additional research is required to discriminate between these possibilities.

The fact that variability of generated approach angles was large does not detract from the importance of runway size effects. The effect of varying runway size is to shift the distribution of pilot responses that can occur in a given situation up or down the scale of approach angles.

Giving pilots knowledge of runway size did not have any effect on the magnitude of illusions due to variation in runway size. This finding most probably reflects the unconscious nature of the process involved in the perception of approach angle. Harris (6) has theorized that due to the unconscious nature of perception, simply telling pilots of the danger of visual illusions in night approaches will not lessen that danger as long as the pilot still relies on the same vulnerable perceptual process. The present finding supports Harris' view. The need for improved techniques of training pilots to counteract visual illusions in night visual approaches and to adapt to different runway situations is clear.

#### OVERVIEW

The findings of this study provide empirical evidence of illusions in judgments of approach angle due to variations in both length and width of runways. The findings also demonstrate the interaction of recent practice with a specific runway with those runway size effects. These findings add to the accumulating body of experimental evidence concerning the existence of different sources of errors in the perception of approach angle, errors which make the night approach situation dangerous, especially in the visual environment called the "black hole," where the only lights visible on the ground are the edge and end lights of the runway (17,20,21). These findings also support a prediction of (i) increased chance of making a dangerous, low approach when a pilot flies a nighttime approach to an unfamiliar runway that has a large ratio of length to width and (ii) an even greater danger if the pilot's recent experience was with a runway with a smaller ratio of length to width.

These data also support previous studies which show judgment of approach angle to be extremely variable in the nighttime approach situation (10,17). Although it is sometimes stated that cues in the runway image formed by the boundary-marking (edge) lights represent the minimum cues that a pilot needs for landing (16), the results of the present study add to a growing base of

evidence that these cues may often be a source of rather large error in judgment of approach angle, and are, therefore, insufficient for a safe approach to landing. The present findings also support the recommendation that landing aids such as Instrument Landing Systems (ILS), and Visual Approach Slope Indicator (VASI) systems be utilized at night to supplement natural visual information at all airports where, otherwise, the lack of surrounding ground lights forces reliance on ineffective visual cues even in good visibility conditions. Although the problem of varying the amount of information on the approach scene can be performed most easily in the laboratory or through use of a computer-controlled aircraft simulator with a CGI visual display, there remains a continuing need for studies of flight paths in actual night approaches as a function of environmental conditions, including variation in runway size, to validate the simulation data recorded in this study.

## REFERENCES

1. Busby, D. E.: Visual Illusions: Runway Width and Slope. FAA AVIATION NEWS, 14:12-13, 1975.
2. Busby, D. E.: Visual Illusions II: Terrain Features. FAA AVIATION NEWS, 14:16-17, 1976a.
3. Busby, D. E.: Visual Illusions III: Atmospheric Distortion. FAA AVIATION NEWS, 14:12-13, 1976b.
4. Busby, D. E.: Visual Illusions IV: Relative Motion. FAA AVIATION NEWS, 14:7, 1976c.
5. Cocquyt, P.: Sensory Illusions. SHELL AVIATION NEWS, 178:19-24, 1953.
6. Harris, J. L., Sr.: What Makes a Visual Approach 'Nonvisual?' AIR LINE PILOT, 46:14-19-, 1977.
7. Hartman, E. O., and G. K. Cantrell: Psychological Factors in "Landing Short" Accidents. FLIGHT SAFETY, 2:26-32, 1968.
8. Hasbrook, A. H.: Anatomy of a Landing Cue by Cue. BUSINESS AND COMMERCIAL AVIATION, 29:54-60, 1971.
9. Hasbrook, A. H.: The Approach and Landing: Cues and Clues to a Safe Touchdown. BUSINESS AND COMMERCIAL AVIATION, 32:39-43, 1975.
10. Hasbrook, A. H., P. G. Rasmussen, D. M. Willis, and M. M. Conners: Pilot Performance and Stress Response During Day and Night Visual Landing Approaches. Unpublished paper presented at the 1975 annual scientific meeting of the Aerospace Medical Association, San Francisco, California, April 29 - May 1, 1975.
11. Kirchner, O. E.: Critical Factors in Approach and Landing Accidents, Part 1 - Statistics. Flight Safety Foundation, December 1960.
12. Kraft, C. L.: Measurement of Height and Distance Information Provided Pilots by the Extra-Cockpit Visual Scene. In: Visual Factors in Transportation Systems: Proceedings of Spring Meeting, Committee on Vision, National Academy of Sciences, National Research Council, Washington, D.C., pp. 84-101, 1969.
13. Kraft, C. L.: A Psychophysical Contribution to Air Safety: Simulator Studies of Visual Illusions in Night Approaches. In: H. L. Pick, Jr., H. W. Liebowitz, J. E. Singer, A. Steinschneider, and H. W. Stevenson (Eds.), Psychology: From Research to Practice. New York: Plenum Press, pp. 363-385, 1978.
14. Kraft, C. L., and L. W. Shaffer: Visual Criteria for Out of the Cockpit Visual Scenes. In: North Atlantic Treaty Organization AGARD Proceedings, 249:3-1 to 3-8, 1979.

15. Kuhlman, R. L.: Approach With Care. FLYING, 78:88-90, 1966.
16. Langewiesche, W.: Stick and Rudder. New York: McGraw-Hill, 1944.
17. Lewis, M. F., and H. W. Mertens: Pilot Performance During Simulated Approaches and Landings Made With Various Computer-Generated Visual Glidepath Indicators. AVIATION, SPACE, AND ENVIRONMENTAL MEDICINE, 50: 991-1002, 1979.
18. Lewis, M. F., H. W. Mertens, and T. Kempzell: A Real-Time Graphics Systems for RSX-11D. In: Proceedings of the Digital Equipment Computer Users Society, 2:441-442, 1975.
19. Mertens, H. W.: Laboratory Apparatus for Studying Visual Space Perception of the Pilot in Simulated Night Approaches to Landing. PERCEPTUAL AND MOTOR SKILLS, 45:1331-1336, 1977.
20. Mertens, H. W.: Comparison of the Visual Perception of a Runway Model in Pilots and Nonpilots During Simulated Night Landing Approaches. AVIATION, SPACE, AND ENVIRONMENTAL MEDICINE, 49:1043-1055, 1978.
21. Mertens, H. W.: Runway Image Shape as a Cue for Judgment of Approach Angle. FAA Office of Aviation Medicine Report No. AM-79-25, 1979.
22. Miholick, J. I.: Pilot Induced Landing Mishaps Where Visual Cues Were a Factor. USAF Safety Officer's Study Kit, December 1977.
23. Pitts, D. G.: Visual Illusions and Aircraft Accidents. USAF School of Aerospace Medicine Division (AFSC), Brooks AFB, Texas, SAM-TR-67-28, 1967.
24. Riordan, R. H.: Monocular Visual Cues and Space Perception During the Approach to Landing. AEROSPACE MEDICINE, 45:466-771, 1974.
25. Vinacke, W. E.: Illusions Experienced by Aircraft Pilots While Flying. JOURNAL OF AVIATION MEDICINE, 18:308-325, 1947.
26. Wulfeck, J. W., A. Weisz, and M. W. Raben: Vision in Military Aviation. Wright-Patterson Air Development Center, Air Research and Development Command, Wright-Patterson AFB, Ohio, WADC Technical Report 58-399, 1958.