

D 1. 112: 81-8

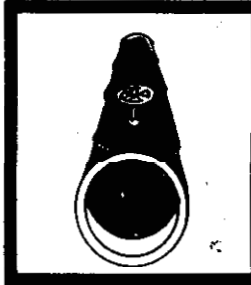

NATIONAL TRANSPORTATION SAFETY BOARD

WASHINGTON, D.C. 20594

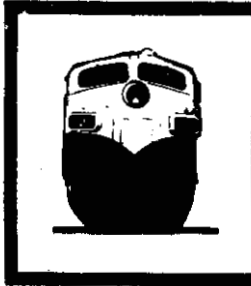
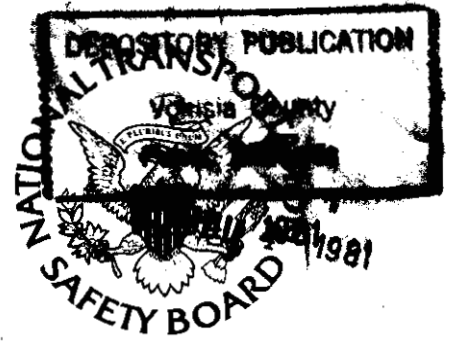

AIRCRAFT ACCIDENT REPORT

TRANS WORLD AIRLINES, INC.,
BOEING 727-31, N840TW
NEAR SAGINAW, MICHIGAN
APRIL 4, 1979

NTSB-AAR-81-8

C. S.

*NTSB
AAR
81-8
C. S.*

Doc
NTSB
AAR
81/08
C.4

UNITED STATES GOVERNMENT

TECHNICAL REPORT DOCUMENTATION PAGE

1. Report No. NTSB-AAR-81-8		2. Government Accession No. PB81-910408		3. Recipient's Catalog No.	
4. Title and Subtitle Aviation Accident Report--Trans World Airlines, Inc., Boeing 727-31, N840TW, Near Saginaw, Michigan, April 4, 1979				5. Report Date June 9, 1981	
7. Author(s)				6. Performing Organization Code	
9. Performing Organization Name and Address National Transportation Safety Board Bureau of Accident Investigation Washington, D.C. 20594				8. Performing Organization Report No.	
12. Sponsoring Agency Name and Address NATIONAL TRANSPORTATION SAFETY BOARD Washington, D. C. 20594				10. Work Unit No. 2629C	
				11. Contract or Grant No.	
				13. Type of Report and Period Covered Aircraft Accident Report April 4, 1979	
				14. Sponsoring Agency Code	
15. Supplementary Notes The subject report was distributed to NTSB mailing lists: 1A, 8A and 8B.					
16. Abstract About 2148 e.s.t., on April 4, 1979, a Trans World Airlines, Inc., Boeing 727, operating as Flight 841, entered an uncontrolled maneuver at 39,000 feet pressure altitude near Saginaw, Michigan. The aircraft descended to about 5,000 feet in about 63 seconds before the flightcrew regained control. About 2231, the flightcrew made an emergency landing at Metropolitan Airport, Detroit, Michigan. Of the 89 persons aboard, 8 passengers received minor injuries. The aircraft was damaged substantially. The flight was cruising in visual flight conditions at night at 39,000 feet when the uncontrolled maneuver began; there was no turbulence. There was a cloud layer near 20,000 feet, and, at 2155, the reported weather at Saginaw was 500-foot overcast with 3 miles visibility in light snow; small breaks were reported in the overcast. Analysis of the evidence indicated that the uncontrolled maneuver began about 2147:47 with isolation of the aircraft's No. 7 leading edge slat (on its right wing) in the extended or partially extended position. During the preceding 14 seconds, the aircraft had rolled slowly to the right to about 35° of right bank and was returned to near wings level flight. Thereafter, the aircraft rolled again to about 35° of right bank in about 4 seconds. About 2147:51, the right roll was stopped near 35° of bank for a few seconds. At that time, the aircraft reached a					
17. Key Words Boeing 727, leading edge slat, spiral dive, lateral Controls, high speed buffet, vertical acceleration, performance envelope, maneuvering envelope, heading gyro gimbal errors, flight simulation, flight tests.				18. Distribution Statement This document is available to the public through the National Technical Information Service-Springfield, Virginia 22161 (Always refer to number listed in item 2)	
19. Security Classification (of this report) UNCLASSIFIED		20. Security Classification (of this page) UNCLASSIFIED		21. No. of Pages 55	22. Price

Abstract continued

condition wherein mach number, angle of attack, and sideslip combined to reduce the aircraft's lateral control margin to zero or less, and the aircraft continued to roll to the right in a descending spiral. During the following 33 seconds, the aircraft completed 360° of roll while descending to about 21,000 feet. The aircraft entered a second roll to the right during which the No. 7 slat was torn from the aircraft. Control of the aircraft was regained about 2148:58 at an altitude of about 8,000 feet.

The Safety Board determines that the probable cause of this accident was the isolation of the No. 7 leading edge slat in the fully or partially extended position after an extension of the Nos. 2, 3, 6, and 7 leading edge slats and the subsequent retraction of the Nos. 2, 3, and 6 slats, and the captain's untimely flight control inputs to counter the roll resulting from the slat asymmetry. Contributing to the cause was a preexisting misalignment of the No. 7 slat which, when combined with the cruise condition airloads, precluded retraction of that slat. After eliminating all probable individual or combined mechanical failures, or malfunctions which could lead to slat extension, the Safety Board determined that the extension of the slats was the result of the flightcrew's manipulation of the flap/slat controls. Contributing to the captain's untimely use of the flight controls was distraction due probably to his efforts to rectify the source of the control problem.

CONTENTS

SYNOPSIS		1
1. FACTUAL INFORMATION		2
1.1 History of the Flight		2
1.2 Injuries to Persons		3
1.3 Damage to Aircraft		4
1.4 Other Damage		4
1.5 Personnel Information		4
1.6 Aircraft Information		4
1.7 Meteorological Information		5
1.8 Aids to Navigation		5
1.9 Communications		5
1.10 Aerodrome and Ground Facilities		6
1.11 Flight Recorders		6
1.12 Wreckage and Impact Information		6
1.13 Medical and Pathological Information		8
1.14 Fire		8
1.15 Survival Aspects		8
1.16 Tests and Research		8
1.16.1 Boeing Company Tests		9
1.16.2 Flight Simulator Tests		9
1.16.3 Heading Gyro Tests		11
1.16.3 Flight Tests		12
1.17 Additional Information		14
1.17.1 B-727 Flap System		14
1.17.2 History of 3-727 Leading Edge Slat Problems		18
1.17.3 Aircraft Performance		18
1.17.4 No. 7 Leading Edge Slat Operation		20
1.17.5 TWA Flight Operations Safety Bulletin 79-3		22
1.18 Useful or Effective Investigative Techniques		22
2. ANALYSIS		22
2.1 The Flightcrew		22
2.2 Weather		22
2.3 The Aircraft		22
2.4 Extension of the No. 7 Leading Edge Slat		23
2.5 Loss of Aircraft Control		27
3. CONCLUSIONS		33
3.1 Findings		33
3.2 Probable Cause		35
4. RECOMMENDATION		35
5. APPENDIXES		37
Appendix A--Investigation and Hearing		37
Appendix B--Personnel Information		38
Appendix C--Flight Data Recorder Plot		39
Appendix D--CVR Transcript		40
Appendix E--Boeing Operations Manual Bulletin 75-7		49
Appendix F--Flight Test Data		51

NATIONAL TRANSPORTATION SAFETY BOARD
WASHINGTON, D.C. 20594

AIRCRAFT ACCIDENT REPORT

Adopted June 9, 1981

TRANS WORLD AIR LINES, INC.
BORING 727-31, N840TW
NEAR SAGINAW, MICHIGAN
APRIL 4, 1979

SYNOPSIS

About 2148 e.s.t., on April 4, 1979, a Trans World Airlines, Inc., Boeing 727, **operating as Flight 841**, entered an uncontrolled maneuver at 39,000 feet pressure altitude **near Saginaw, Michigan**. The aircraft descended to about 5,000 feet in about 63 seconds before the flightcrew regained control. About 2231, the flightcrew made an emergency landing at Metropolitan Airport, Detroit, Michigan. Of the 89 persons aboard, 8 passengers received minor injuries. The aircraft was damaged substantially.

The flight was cruising in visual flight conditions at night at 39,000 feet when the uncontrolled maneuver began; there was no turbulence. There was a cloud layer near 20,000 feet, and at 2155, the reported weather at Saginaw was 500-foot overcast with 3 miles visibility in light snow; small breaks were reported in the overcast.

Analysis of the evidence indicated that the uncontrolled maneuver began about 2147:47 with isolation of the aircraft's No. 7 leading edge slat (on its right wing) in the extended or partially extended position. During the preceding 14 seconds, the aircraft had rolled slowly to the right to about 3° of right bank and was returned to near wings level flight. Thereafter, the aircraft rolled again to about 3° of right bank in about 4 seconds. About 2147:51, the right roll was stopped near 3° of bank for a few seconds. At that time, the aircraft reached a condition wherein mach number, angle of attack, and sideslip combined to reduce the aircraft's lateral control margin to zero or less, and the aircraft continued to roll to the right in a descending spiral. During the following 33 seconds, the aircraft completed 360° of roll while descending to about 21,000 feet. The aircraft entered a second roll to the right during which the No. 7 slat was torn from the aircraft. Control of the aircraft was regained about 2148:58 at an altitude of about 8,000 feet.

The Safety Board determines that the probable cause of this accident was the isolation of the No. 7 leading edge slat in the fully or partially extended position after an extension of the Nos. 2, 3, 6, and 7 leading edge slats and the subsequent retraction of the Nos. 2, 3, and 6 slats, and the captain's untimely flight control inputs to counter the roll resulting from the slat asymmetry. --Contributing to the cause was a preexisting misalignment of the No. 7 slat which, when combined with the cruise condition airloads, precluded retraction of that slat. After eliminating all probable individual or combined mechanical failures, or malfunctions which could lead to slat extension, the Safety Board determined that the extension of the slats was the result of the flightcrew's manipulation of the flap/slat controls. Contributing to the captain's untimely use of the flight controls was distraction due probably to his efforts to rectify the source of the control problem.

1 FACTUAL INFORMATION

11 History of the Flight

On April 4, 1979, Trans World Airlines Flight 841, a Boeing 727-31 (N840TW), operated as a scheduled passenger flight from John F. Kennedy International Airport, New York (JFK), to Minneapolis-St. Paul International Airport, Minnesota. After a delay of about 45 minutes due to traffic congestion, Flight 841 departed JFK with 82 passengers and 7 crewmembers aboard at 2025. ^{1/}

About 2054, Flight 841 reached flight level (FL) 350, ^{2/} to which it had been cleared. At 2124, the flight called Toronto Center and asked for any report on winds at FL 310 or FL 390. The Toronto Center controller replied that he had no reports from other flights. Flight 841 stated that it was encountering a headwind of 100 knots or more, and about 2125, the flight requested clearance to FL 390. The flight was cleared to FL 390, and at 2138:44, it reported reaching FL 390. The captain stated that he climbed the aircraft at 0.80 mach, leveled the aircraft at 39,000 feet at that speed, and engaged the autopilot in the Altitude Hold mode.

According to the fuel and flight data log, at 2140 the second officer estimated that the aircraft's gross weight was 131,700 pounds. According to the flightcrew, the takeoff, climb, and en route portions of the flight were uneventful and no problems occurred until about 9 minutes after the aircraft reached FL 390. The captain stated that the flight was in visual flight conditions at FL 390 and that there was no turbulence. The flight was cruising at about 252 KIAS with all systems indicating normal operation. There were no warning lights visible, and no changes were made to the aircraft's configuration.

The captain stated that he was flying the aircraft on autopilot with the Altitude-Hold mode selected. While he was sorting maps or charts, which were located in his flight bag on the left cockpit floor, he felt a buzzing sensation. Within 2 or 3 seconds, the buzzing became a light buffet, and he looked at the flight instruments. He noticed that the autopilot was commanding a turn to the left with the control wheel displaced accordingly, but he noticed that the attitude director indicator (ADI) showed the aircraft in a 20° to 30° bank to the right. The ADI showed that the aircraft was continuing to bank to the right at a slightly faster than normal rate of roll, so he disconnected the autopilot and applied more left aileron control to stop the roll.

According to the captain, the aircraft continued to roll to the right in spite of nearly full left aileron control, so he applied left rudder control in addition to the aileron control. He stated that in spite of the almost full deflection of the left aileron and full displacement of the left rudder pedal, the aircraft continued to roll to the right. He believed that the aircraft was going to roll inverted so he retarded the throttles to the flight idle position, and he stated "we're going over," or something to that effect. The aircraft rolled completely and entered a second roll with the nose down.

The captain asked the first officer to "get them up," meaning that he wanted the first officer to extend the speed brakes. The first officer stated that he was not aware of the buffeting or the aircraft's attitude because he was in the process of calculating the aircraft's groundspeed; therefore, he did not understand the captain's

^{1/} Unless otherwise noted, all times herein are eastern standard, based on the 24-hour clock.

^{2/} A level of constant atmospheric pressure related to a reference datum of 29.92 inches of mercury; for example, FL 350 represents a barometric altimeter indication of 35,000 feet.

command. The flight engineer was aware of the buffeting but was facing his panel and was not aware initially of the aircraft's attitude except that it seemed to be in a right descending turn. The captain stated that when the first officer did not react to his command, he moved the speed brake lever to the deployed position.

After detecting no reaction to the speed brake extension, the captain moved the control handle to the retract position and back to the extend position. Meanwhile, the indicated airspeed needle was moving rapidly toward its limit and he could see only "black" on the ADI and bright areas in the windshield which he perceived to be the lights of towns shining through the undercast. The altimeter indicated such a rapid descent that it was difficult to read. However, he estimated that the aircraft was near 15,000 feet and descending rapidly when he commanded extension of the landing gear. The first officer immediately moved the gear handle to the "extend" position, and the flightcrew heard a very loud sound similar to the sound of an explosion.

The captain stated that he applied full left aileron and full left rudder throughout the descent but the aircraft continued to roll to the right. Simultaneous with the gear extension, he relaxed some of the back pressure on the control column and some of the pressure on the aileron and rudder controls. The airspeed began to slow, and he was able to roll the aircraft to a near wings-level attitude and to stop the aircraft's descent, after which the aircraft pitched upward into a 30° to 50° climb. He saw the moon in the windscreen and used it as a visual reference to maneuver the aircraft. The airspeed slowed rapidly, and with guidance from the first and second officers, he leveled the aircraft near 13,000 feet.

After regaining control of the aircraft, the flightcrew noticed a warning light announcing the failure of the "A" hydraulic system and a warning flag indicating that the lower yaw damper was inoperative. The captain decided to land the aircraft at Metropolitan Airport, Detroit, Michigan. He instructed the first officer and flight engineer to perform emergency checklist procedures and to notify the flight attendants to prepare the passengers for an emergency landing.

The captain stated that when the landing flaps were extended during the approach by means of the alternate extension system, the aircraft rolled sharply to the left. Therefore, he ordered the flaps retracted and planned for a landing without flaps. The two main landing gear indicators showed unsafe landing gear conditions, so the captain made a low altitude pass down the runway for a check of the landing gear. Control tower and crash rescue personnel reported that all three landing gears appeared to be extended. About 2231, the captain landed the aircraft on runway 3 without incident.

The accident occurred at night (about 2148) near latitude 43°39'N and longitude 84°05'W.

1.2 Injuries to Persons

<u>Injuries</u>	<u>Crew</u>	<u>Passengers</u>	<u>Others</u>	Total
Fatal	0	0	0	0
Serious	0	0	0	0
Minor/None	7	82	0	89

13 Damage to Aircraft

The aircraft was damaged substantially; it was repaired and returned to service in late May 1979.

14 Other Damage

None.

15 Personnel Information

The flightcrew was qualified and certificated for the flight and had received the training required by regulation. (See appendix B.)

The flightcrew had reported for duty in Los Angeles, California, on April 3, 1979, about 1130. They had flown a series of flights that terminated in Columbus, Ohio, about 2205. On the day of the accident, the flightcrew reported for duty about 1345 and flew to New York, New York, with an en route stop at Philadelphia, Pennsylvania. They arrived at JPK about 1720. All members of the flightcrew stated that they felt no fatigue on April 4.

The captain of Flight 841 first qualified as a captain on B-727 aircraft on February 3, 1969. Later, he had flown as a first officer or captain on various aircraft. Most recently, he had flown as a first officer on B-747 aircraft from November 1977 to December 1978. From late December 1978 until March 11, 1979, the captain was on medical leave, recovering from a broken ankle. On March 15 and 16, 1979, he took a ground school refresher course in the B-727, and on March 19 and 20, he flew the B-727 simulator for 4 hours. On March 21, he received a simulator check, and he made three landings in the B-727 aircraft. On March 28, the captain successfully completed a line check in the B-727 which lasted 5 hours, 21 minutes. On April 3, he began his first line trip since returning to duty. During the 90-day period preceding the accident, the captain flew 21 hours 50 minutes, all in the B-727.

16 Aircraft Information

N840TW was owned and operated by Trans World Airlines, Inc. (TWA), and was certificated and maintained in accordance with current regulations. It was purchased from The Boeing Company on July 13, 1965. N840TW had acquired about 35,412 hours in service.

The aircraft received a "C" check on March 1, 1979, and it had been flown 230 hours 13 minutes since that check. Maintenance records indicated that during the "C" check, suspected hydraulic leaks in the No. 8 spoiler actuator, No. 4 and No. 5 leading edge flap actuators, and No. 6 and No. 7 leading edge slat actuators were either invalidated or were repaired. The No. 7 leading edge slat's inboard track fairing was repaired. There were no significant maintenance discrepancies on the aircraft maintenance logs after the "C" check.

The aircraft's planned gross weight for takeoff was 145,095 pounds (lbs) with 36,000 lbs of fuel on board. About 1,500 lbs of fuel were consumed during the delay preceding the takeoff. At the time of the accident, the aircraft's center of gravity was within prescribed limits at 24.1 percent mean aerodynamic chord and the aircraft's gross

weight was about 130,400 lbs. After the aircraft had landed and after the engines were stopped, according to the aircraft's fuel gages, 13,890 lbs of fuel were on board: 4,580 lbs in the No. 1 tank; 4,710 lbs in the No. 2 tank; and 4,600 lbs in the No. 3 tank.

1.7 Meteorological Information

At 1900 on April 4, 1979, the National Weather Service's (NWS) upper air analysis showed southwesterly winds at the 200-, 250-, and 300-millibar levels ^{3/} through New York and Michigan. The wind speeds were 100 to 110 knots in eastern New York, 35 to 50 knots in western New York, and 80 to 85 knots in east-central Michigan. In eastern and central Michigan, the air temperature at the 200-millibar level was about -49° C.

The 1800 radiosonde observation at Flint, Michigan, showed temperatures of -48.9° C at 38,000 feet and -53° C at 44,400 feet. Near 39,000 feet, measured winds were from 230° true at 85 knots. The tropopause was near 30,000 feet.

The surface weather observations at the following times and locations were, in part:

Saginaw, Michigan

2155 - Clouds—measured ceiling 500-ft overcast; visibility—3 mi in light snow; wind—350' at 5 kns; remarks—small breaks in the overcast.

Detroit, Michigan

2153 - Clouds—800-ft scattered, measured overcast ceiling at 2,000 ft; visibility—? mi; wind—310' at 11 kns; remarks—snow ended at 2135.

NWS weather radar observations taken at Detroit at 2130 and 2230 showed that no precipitation echoes existed within 250 miles of Detroit.

Weather reports submitted by pilots were, in part, as follows:

2019 - Peck VOR, Michigan, PL 310—sky clear, no turbulence, temperature -45° C, winds 270' at 80 kns.

2026 - Flint, Michigan, FL 350—sky clear, no turbulence, temperature -48° C, winds 240' at 100 kns.

According to U.S. Naval Observatory astronomical data, on April 4, 1979, at 2150, at latitude 43°39'N and longitude 84°05'W, a half moon was visible at an azimuth of 242' from true north and at an elevation of 48° above the horizon.

1.8 Aids to Navigation

Navigational aids were not a factor in this accident.

1.9 Communications

There were no problems with communications.

^{3/} Pressure levels corresponding approximately to pressure altitudes of 39,000, 34,000, and 30,000 feet, respectively.

1.10 Aerodrome and Ground Facilities

There were no problems with the aerodrome or ground facilities.

1.11 Flight Recorders

The aircraft was equipped with a Lockheed Aircraft Services Model 109-D flight data recorder (FDR), serial No. 219. The recording foil was not damaged and all four flight parameters were clear and active. (See appendix C.) There was no evidence of malfunction except at one point in the heading trace where the heading stylus moved in a direction opposite to normal movement of the recording foil while the aircraft was in a turn and was being subjected to high vertical acceleration forces. Further examination of the heading trace disclosed that this abnormality occurred again when the aircraft was turning off the runway at Detroit. A detailed examination of the recorder heading trace mechanism disclosed no explanation for these abnormalities. However, according to the manufacturer, the backward movement of the heading stylus (apparent time shifts) were caused by worn mechanisms in the FDR.

The aircraft was equipped with a Fairchild Industries Model A-100 cockpit voice recorder (CVR), serial No. 829. The CVR was not damaged; however, 21 minutes of the 30-minute tape were blank. The remaining 9 minutes of tape were of good fidelity, but they pertained only to flightcrew conversations after the aircraft was on the ground at Detroit. (See appendix D.)

Tests of the CVR in the aircraft revealed no discrepancies in the CVR's electrical and recording systems. The CVR tape can be erased by means of the bulk-erase feature on the CVR control panel located in the cockpit. This feature can be activated only after the aircraft is on the ground with its parking brake engaged. In a deposition taken by the Safety Board, the captain stated that he usually activates the bulk-erase feature on the CVR at the conclusion of each flight to preclude inappropriate use of recorded conversations. However, in this instance, he could not recall having done so. The first and second officers both stated that they did not erase the tape nor did they see the captain activate the erase button on the CVR control panel.

1.12 Wreckage and Impact Information

The No. 7 leading edge slat on the right wing was missing. The slat tracks remained on the aircraft; the outboard track was twisted and bent rearward about midspan, and the inboard track was bent rearward near the aft end of the track. The slat actuator cylinder was broken about 1 1/2 inches forward of its trunnion; the aft portion of the cylinder remained attached to the wing. The forward end of the actuator cylinder, the actuator piston, and the piston rod were missing. The 5/16-inch bolts that attach the slat to its track were sheared. The inboard fairing-adjustment T-bolt was broken, and the threaded portion of the bolt and two adjusting nuts were missing. The inboard slat hook showed no evidence of engagement with the hook stop - the chromate paint was intact while the paint on the outboard hook was partially worn.

The skin of the lower surface of the wing aft of the No. 7 slat actuator was scraped. An 8- to 10-inch portion of the outboard aileron balance tab was missing at the end of the scrape mark. The balance tab actuator lugs had separated, and the hinge support fitting between the lugs had sheared.

The right outboard aileron actuator hinge fitting bolt was broken. With the aileron in the locked-out position, there was free movement of 1 inch up and 3/32 inch down at the trailing edge of the aileron. The nut end of the bolt remained in the structure. A metallurgical examination of the bolt indicated that it had failed predominantly in fatigue.

The No. 10 flight spoiler panel, except for a portion containing the two inboard hinges, was missing. The right inboard trailing edge flap track attachment bolts were sheared and the carriage was damaged. The canoe-shaped fairing for the track was missing.

The No. 7 leading edge slat, which had broken into two pieces, and the right outboard trailing edge flap track canoe-shaped fairing were found about 7 miles north of Saginaw, Michigan, at latitude 43°39'N and longitude 84°05'W. A large portion of the No. 10-spoiler panel was found about 3/4 mile south of these components. The forward portion of the No. 7 slat actuator cylinder, the actuator piston, and the piston rod were not found. The piston rod-end bearing remained attached to the slat; the rod had fractured in overload about 2 inches aft of the center of the bearing.

A metallurgical examination of the No. 7 slat inboard T-bolt indicated that the cross section of the bolt had fatigue fracture characteristics. There was considerable smearing of the fracture face.

Both main gear landing doors and their operating mechanisms were damaged extensively and a hydraulic line was ruptured. The sidebrace and actuator support beam on the right gear were broken; the support beam for the left gear was intact. The uplock for the left gear was bent. The secondary wing skin panels above both actuator support beams were buckled upward.

The No. 4 flight spoiler was torn around its actuator attachment point. Fuel was leaking around several structural fasteners in the left wing. The aft fairing on the left outboard trailing edge flap jackscrew was broken and the forward fairing was missing. The left outboard aileron balance tab hinge fitting was broken; in the locked-out position, there was no appreciable free movement of the aileron.

Slight tension-field wrinkles had formed in the fuselage skin fore and aft of the wing attachment areas. The nose gear door was damaged. Both inboard flap jackscrew fairings were loose and both transmission housings were broken. Two blowout panels on the bottom of the No. 3 engine support strut were missing.

Many passenger oxygen masks were hanging from their overhead compartments. A passenger service unit was loosened from its moorings and an interior window was qacked.

The "A" hydraulic system reservoir contained 2 quarts of fluid. Following repair of the hydraulic line in the right wheel well and plugging of the No. 7 slat actuator lines, the reservoir was serviced and the flight controls and speed brakes were checked; they functioned properly. Except for the No. 7 leading edge slat, the leading edge slats and flaps, trailing edge flaps, and their indicator lights functioned properly on both the normal and alternate flap systems. The inboard trailing edge flaps could not be tested because of the damage to the right inboard trailing edge flap. The stall warning and overspeed warning systems functioned properly.

The following components were removed from the airplane and were functionally tested: (1) Kollsman integrated flight instrument system, (2) captain's and first officer's airspeed and mach indicators, (3) yaw dampers, (4) autopilot control panel and pitch roll channels, (5) air data sensor, and (6) both instantaneous vertical speed indicators. All components, except one airspeed indicator, functioned within specified tolerances; the airspeed indicator was about 4 knots out of tolerance in the 240- to 260-knot speed range.

The No. 4 and No. 10 spoiler actuators were tested and they functioned satisfactorily. The remaining portion of the No. 7 slat actuator, including the switch mechanism, one lockring, and the shuttle valve, was examined. A production piston assembly could not be inserted into the broken end of the cylinder bore, but after removal of the end cap, it could be inserted into the opposite end of the bore and into the normal retracted position. However, the piston could not be moved past the retracted position through the broken end of the bore. Dimensional analysis of the bore disclosed that it was distorted near the broken end. The actuator bore was not scored, scraped, or marked.

Further ~~tests~~ at the aircraft manufacturer's facility indicated that when 3,000 psi of hydraulic pressure was applied to the extend face of the production piston, the piston would not move out of the broken end of the actuator bore; instead, the hydraulic fluid leaked between the bore distortions and the piston seal. A mechanical force of 1,025 pounds was required to force the piston out of the broken end of the actuator bore; the actuator bore was gouged and scraped by the piston as it moved through the bore.

1.13 Medical and Pathological Information

The flightcrew was not examined medically.

Of the five passengers who immediately reported injuries, two passengers were taken by ambulance to a local hospital where they were treated and released. Three passengers reported pains in their chests, necks, and backs, but they refused medical treatment. One passenger's knee was bruised and bleeding, and her ankle was swollen. The passengers' injuries consisted primarily of strains and bruises. All five passengers flew to Minneapolis-St. Paul on another flight which departed Detroit about 0245 on April 5, 1979. Later, three other passengers reported injuries, but only one was hospitalized for severe muscle strain of the back and neck and a vertigo/balance problem.

1.14 Fire

There was no fire.

1.15 Survival Aspects

This was a survivable accident. The injury causing mechanism was the variable but comparatively high in-flight load factor -- maximum of about 6.0 g's -- and its duration. The high g's forced the occupants' heads and upper extremities toward the floor of the cabin and caused the muscle strains of the neck and back. Passengers who were standing when the maneuver began were forced to the floor and, in the process, contacted objects that caused bruises and cuts.

1.16 Tests and Research

1.16.1 Boeing Company Tests

In 1975, The Boeing Company conducted flight and wind tunnel tests to determine the effects of asymmetric extension of wing leading edge slats on the control characteristics of the B-727 while in cruise flight conditions. Because of reports of slat actuator locking failures, these tests were conducted to evaluate control characteristics associated with an unscheduled extension of a single leading edge slat. The wind tunnel tests involved slat extensions from 0.4 to 0.95 mach; because of adverse buffeting, 0.8 mach was the highest speed tested in flight. From these tests, it was determined that the extension of either the No. 2 or the No. 7 leading edge slat caused the most adverse control characteristics, but with a significant amount of lateral control applied, the aircraft was controllable at altitudes and speeds of up to and including 35,000 feet and 0.80 mach. As the result of these tests, The Boeing Company issued Operations Manual Bulletin (OMB) 75-7 in August 1975, to provide flightcrews with operational information for the event of an actual or suspected leading edge slat actuator locking malfunction. (See appendix E for revised OMB 75-7, issued March 10, 1976.)

1.16.2 Flight Simulator Tests

At the request of the Safety Board, The Boeing Company programed a fixed-base engineering flight simulator with B-727-200 4/ aerodynamic and control data and the data obtained from the 1975 flight and wind tunnel tests. Also, the simulator was programed with Flight 841's gross weight and center of gravity conditions and the pertinent meteorological data associated with its flight. A total of 118 trials were conducted in the flight simulator to identify the condition that precipitated the aircraft's upset and to duplicate and evaluate its maneuver.

The effects of spurious signals to the autopilot and yaw damper were explored. ^{Rolls} ~~and~~ ^{out} ~~the~~ ^{side} ~~effects~~ ^{maneuver} were explored. In all cases, the simulator pilots were able to overcome the effects with no difficulties. There was no correlation between the simulator traces of these maneuvers and Flight 841's FDR traces.

The simulator tests did not take into consideration the effects of freeplay in the right out-board aileron or possible distortion of the No. 7 leading edge slat. Also, the simulations did not include lateral control requirements due to sideslip. However, the effect of 1 3/32 inches of free play in the right outboard aileron was explored. About 13° of control wheel deflection to the left was needed to counter the effect; this deflection was within the autopilot's authority of about 38° of control wheel deflection. The control wheel must be deflected about 80° to obtain full deflection of the lateral controls.

Extensions of the No. 7 leading edge slat while in level flight at 39,000 feet and at 0.80 mach consistently generated rolls to the right. Additionally, the autopilot countered the right rolls to the full extent of its authority within 2 seconds of slat extension, and the yaw damper countered the resulting sideslip with rudder displacement to the left. The initial roll rate with the autopilot engaged was about 7° per second to the right. Despite the countercontrols applied by the autopilot, the simulated aircraft continued to roll to the right. When the pilots disconnected the autopilot at 30' of right bank and applied additional left aileron control, the simulated aircraft returned to

4/ According to the Boeing Company, the control systems and aerodynamic characteristics of the B-727-200 are virtually identical to the B-727-100. The only aerodynamic differences relate to a 10-foot longer fuselage on the B-727-200.

wings-level flight which could be maintained with about 46° of control wheel displacement to the left. Under conditions of the simulations, the right roll could be stopped and the aircraft returned to wings-level flight provided corrective measures were taken before the roll progressed beyond about $117'$ of right bank. Beyond that bank angle, increases in angle of attack and mach produced an imbalance of rolling moments that could not be overcome with lateral and rudder controls, and the aircraft became uncontrollable.

The simulator tests produced two flight maneuver situations in which the recorded time histories of indicated airspeed, altitude, and normal load factors most closely approximated those recorded by Flight 841's FDR. The recorded time history of the simulator's heading trace differed from the FDR heading trace because the simulator's heading reference system was not subject to the gimbal errors associated with the aircraft's heading gyro.

In both maneuvering situations, the entry and the pilots' actions were similar; the latter differed **only** in the amount of controls applied and the length of delay in control application following slat extension. The simulator was placed at **39,000** feet at **0.80** mach with the autopilot engaged. After extension of the **No. 7** leading edge slat and a short delay, the pilots disconnected the autopilot and applied left aileron control, followed by left rudder deflection. The pilots retarded the throttles to flight idle and extended the speed brakes. Near **15,000** feet, they extended the landing gear and the slat was retracted (simulating the loss of the slat) and recovery to level flight was completed. Since load factors could not be simulated, the pilots attempted to duplicate Flight 841's longitudinal control deflections and g-trace by referring to a g-meter. The stabilizer trim was not moved from the cruise trim (zero stick-force) position.

The flight simulator traces showed that the simulated aircraft could be returned to wings-level flight with relatively little loss of altitude provided corrective action was begun before the roll and airspeed were allowed to increase excessively. In the simulations, the pilot could delay reaction for about **16** seconds and regain control with an altitude loss of about 6,000 feet. However, when the pilot delayed corrective action for **17** seconds or more, a maneuver was entered that approximated Flight 841's airspeed, altitude, and g-traces. In this maneuver, the aircraft continued throughout the descent to roll to the right, in spite of full left aileron and rudder, until the slat was retracted to simulate its loss from the aircraft.

The second maneuvering situation which produced good correlation between the simulator traces and Flight 841's FDR traces for airspeed, altitude, and g's involved two roll reversals. About **12** seconds after slat extension and at a bank angle of about 60° to the right, the pilot disconnected the autopilot and rapidly applied left aileron and left rudder. In the following **12** seconds, the simulated aircraft rolled **285'** to the left, about **45'** beyond the inverted position, and then it reversed and rolled to the right. By that time, the simulated aircraft's nose had dropped to **40'** below its cruise attitude and its airspeed had increased to **0.86** mach. After the roll reversal to the right, the simulated aircraft continued throughout the descent to roll to the right, in spite of full left aileron and rudder, until the slat was retracted.

In all simulator tests, during the spiraling descents, lateral control was regained after the **No. 7** leading edge slat was retracted to simulate its loss from the aircraft. Several traces from the simulator tests indicated that, while the autopilot was deflecting the control wheel to the left and the aircraft was rolling to the right, fully qualified B-727 pilots disconnected the autopilot, centered the control wheel, and then

rotated the control wheel to the left to counter the right **roll**. This had the effect of momentarily increasing the **roll** rate to the right.

1.16.3 Heading Gyro Tests

In tests in May 1979 to determine the effects of pitch and **roll** angles on heading **gyro** performance, the heading **gyro** from the aircraft was removed and mounted on a movable platform. The heading angle indicated by the **gyro** was displayed on a digital readout of the heading synchro and was recorded. The system was stabilized on Flight 841's cruise heading and attitude which immediately preceded the control problem. The heading **gyro** was then progressively rotated to the heading, pitch, and **roll** angles which were measured in the simulator tests that most nearly duplicated the aircraft's FDR traces of airspeed, altitude, and g's.

Comparison of the simulator heading traces with those obtained from the heading **gyro** tests showed some correlation for the simulator maneuver which developed when the simulator pilot began his corrective action at 60° of right bank and about 12 seconds after slat extension. This was the simulator maneuver which involved double roll reversals; however, about 36 seconds after slat extension, significant disagreement between the heading traces occurred.

In May 1980, additional tests were conducted to determine the effect of **roll**, pitch, and heading angles changes and rates of change on the performance of a B-727 heading **gyro**. By determining these effects, it was believed that a better understanding and interpretation could be achieved of the accident aircraft's motions as reflected in its FDR heading trace.

The heading **gyro** was mounted in a standard bracket and attached to a tilt/turn table. The **gyro** was connected to a compass coupler and flux gate valve to simulate a complete B-727 compass system, and a Lockheed Air Service Model F109-D FDR was used to record the heading information developed from rotation of the gyro through various roll, pitch, and heading angles. Several tests involved the introduction of **roll**, pitch, and heading angles that were derived from the two flight simulation maneuvers that most closely approximated the time histories of airspeed, altitude, and g's recorded on Flight 841's FDR.

The heading traces recorded on the test FDR shifted backward in time in a manner similar to the backward shift of the accident aircraft heading trace which occurred about 2148:01. These time shifts were found to occur at specific bank angles, which made them predictable, and corrections were made to remove the time shifts from the accident aircraft's heading trace and from the test traces. According to the FDR manufacturer, these time shifts were caused by worn recorder mechanisms.

These tests established that for changes in roll angle alone, the magnitude and direction of the heading **gyro** gimbal errors were the same whether the **gyro** was rolled to the right or to the left, and the heading trace generated on the test FDR was essentially the same regardless of the direction of **roll**. Also, the gimbal error was a repeatable function of **roll** attitude and was not affected by roll rate.

With regard to **roll**, pitch, and heading angle changes associated with flight simulation data for a continuous right **roll** entry into the dive, comparison of the test heading trace with the accident heading trace showed poor agreement with the abrupt

heading change to the right that occurred in the latter trace about 2147:45. However, the comparison showed good agreement with the first large heading excursion to the left that began about 2147:54. Comparison of the test heading trace generated from simulator data for the dive entry which involved two roll reversals showed good agreement with the abrupt heading change to the right that occurred about 2147:45 and fair agreement with the subsequent large heading excursion to the left.

Heading traces based on the above simulation data for roll, pitch, and heading angle changes were calculated from the gimbal error equation and were compared with the accident heading trace. The calculated heading trace for the continuous right roll entry data showed poor agreement with the abrupt heading change to the right that occurred about 2147:45 but showed good agreement with the subsequent large heading excursion to the left. Conversely, the calculated trace for the dive entry which involved two roll reversals showed good agreement with the abrupt heading change to the right but poor agreement with the subsequent large excursion to the left. The calculated trace contained an uncharacteristic inflection when the roll reversed from left to right.

1.16.4 Plight Tests

On October 2, 1980, at the request of the Safety Board, the aircraft manufacturer conducted flight tests in an instrumented B-727-100. A Safety Board aerospace engineer assisted in developing the tests and was aboard the aircraft as an observer during the tests. The purposes of the tests were to record data that could be compared with Flight 841's FDR data, to test aircraft and configuration changes that might have occurred to Flight 841 before its rapid descent, and to obtain data on lateral control effectiveness.

The aircraft was equipped with a Lockheed Aircraft Services 109-D FDR and accelerometer of the same types that were aboard the accident aircraft. Additionally, the aircraft was equipped with special flight instrumentation, a Sperry Flight Systems SP150, MB-5 autopilot, and recorders that recorded substantially more parameters with higher accuracy and fidelity than the FDR. All tests were flown as close as practical to the conditions recorded on Flight 841's PDR just before its g-trace began oscillation. The tests involving Configuration changes in level cruise flight were flown for about 1 minute each, following completion of the configuration change, to determine the effects on aircraft performance.

The significant results of these tests were as follows:

- o With the autopilot engaged in Altitude Hold and Manual Mode, when the trailing edge flaps were extended to 2° without extension of the leading edge slats, there were no discernible changes in altitude, g, or heading on the FDR. Airspeed decreased very slightly and slowly.
- o With the autopilot engaged in Altitude Hold and Manual Mode, when the trailing edge flaps were extended to 5° without extension of the leading edge slats, the altitude increased slightly and the airspeed decreased slowly a few knots. Normal acceleration initially increased slightly, then decreased slightly, and then returned to 1.0 g. When the flaps were retracted to 2°, the airspeed increased slowly about 1 knot.

- o With 2° of trailing edge flaps extended and autopilot engaged (Altitude Hold and Manual Mode), when the Nos. 2, 3, 6, and 7 slats were extended, the airspeed decreased at a rate of 0.50 kn/sec., and the altitude remained constant. The g-trace showed an initial increase followed by a periodic undamped oscillation. Moderate buffet (as described by an engineer in the midsection of the aircraft) was indicated on the flight test FDR by g-trace oscillations of ± 0.05 g at a frequency of about 1.0 cycle per second.
- o As drawn on a graph, a comparison of the flight test FDR traces with Flight 841's FDR traces suggests that the only similarities are in the initial rate of airspeed decrease and the amplitude of the g-trace oscillations following first excitation of the g-traces. (See appendix F.) However, 200-power magnification of the g-trace on the FDR foils from the flight test aircraft and the accident aircraft showed that the g-trace on the flight test aircraft oscillated about 6 cycles per second when the Nos. 2, 3, 6, and 7 leading edge slats were extended and that the g-trace on the accident aircraft oscillated about 6 cycles per second beginning about 2147:34. The frequency response of the acceleration channel on both FDR's was tested. These tests showed that the accident aircraft's FDR was slightly more responsive and that the frequency response limit of both FDR's was about 6 cycles per second.

Further, the periodic undamped oscillation of the g-trace from the test aircraft was a characteristic of its autopilot, which was different from the autopilot in the accident aircraft (SP50, MB-3). The primary differences between the two autopilots involve the addition of an altitude rate feedback loop and a higher gain in the altitude feedback loop on the SP150. Additionally, it was determined that during the flight tests higher than normal altitude and altitude rate feedback loop gains were present because a test switch in the digital air data computer (DADC) used by maintenance personnel to functionally test the system had been left in the test (HOLD) position. During simulations of the flight test conditions, the SP150 autopilot (with the DADC test switch in the test position) altitude and altitude rate feedback loops generated nose-up commands to the elevator which partially canceled the nose-down commands to the elevator from the pitch attitude and pitch rate loops. This resulted in a substantial reduction and lag in nose-down elevator response which very nearly duplicated the elevator response recorded during the flight test. Because the SP50, MB-3, autopilot does not have an altitude rate feedback loop and has a reduced gain in the altitude feedback loop, it would have commanded greater nose-down elevator deflections much more rapidly under the same conditions. The effects of earlier and larger nose-down elevator deflections during the flight tests would have been a substantial reduction in the aircraft's initial nose-up pitch attitude and g increase and no subsequent undamped oscillation. Consequently, the flight test aircraft's g-trace would have matched the accident aircraft's g-trace much more closely had the test switch in the DADC been in its proper position. This also was established by simulations of elevator response with the test switch in its proper position.

- o While in a normal cruise configuration and with the autopilot (Altitude Hold and Manual Mode) maintaining the aircraft's heading, the pilot deflected the rudder fully to the right to place the aircraft in a steady left sideslip for the purpose of developing a maximum right yawing moment. When the autopilot was disconnected while the aircraft was in this condition, the control wheel abruptly centered and the aircraft slowly yawed, rolled, and turned to the right.

1.17 Additional Information

1.17.1 B-727 Flap System

The B-727 has eight individual leading edge **slats** and four individual leading edge flaps. The slats are mounted on the outboard positions of the wings and are numbered 1 through 4 on the left wing and 5 through 8 on the right wing. The flaps are on the inboard portion of the wings. (See figure 1.) The leading edge slats and flaps are **high lift devices** that are extended for takeoff and landing. (See figure 2.) According to the TWA Flight Handbook, the maximum speed and altitude with the leading edge devices extended are **240 knots** and **25,000 feet**, respectively, and the maximum speed for extension and retraction is **230 knots**.

Each leading edge device is actuated by a single hydraulic actuator. These actuators are normally supplied by "A" system hydraulic pressure and are normally controlled by the flap handle in the cockpit. With the loss of "A" system pressure, the leading edge devices can be extended by an alternate flap system; once extended by the alternate system, the leading edge devices cannot be retracted until "A" system pressure is restored. When extended by the alternate system, **all** leading edge slats and flaps extend randomly; full extension of **all** devices takes about **40** seconds.

The leading edge devices normally extend and retract in conjunction with the trailing edge flaps. The normal schedule is for extension of the **Nos. 2, 3, 6, and 7** leading edge slats in conjunction with the selection of **2°** of trailing edge flaps and extension of the **No. 1, 4, 5, and 8** slats and the six leading edge flaps in conjunction with the selection of **5°** of trailing edge flaps. The devices are retracted in the same groups in the reverse order of extension. Actual extension and retraction are initiated by the outboard trailing edge flap followup system; that is, slat extension is not initiated until the trailing edge flaps approach the **2°** and **5°** positions and slat retraction occurs when the trailing edge flaps retract from the **5°** and **2°** positions. Normal extension and retraction times for the leading edge devices is about **6** seconds.

All leading edge slats are ^{Hook Stops} held in the extended and retracted positions by hydraulic pressure and by mechanical locking devices in each actuator. (See figure 3.) The lockine devices are held in the locked position by **springs** and hvdraulic pressure and **are** unlocked by hydraulic pressure. A switch on each actuator is connected to the cockpit light displays. One display, on the pilots' instrument panel, provides an amber (in transist) light when an acutator is unlocked, a green light when all actuators are extended and locked, **or** no light when the actuators are retracted and locked. The other display, aft of the flight engineer's panel, provides a display of the condition of each individual leading edge device. When activated, this display will show whether an individual leading edge device is extended and locked (green light), retracted and locked (no light), or unlocked (amber light).

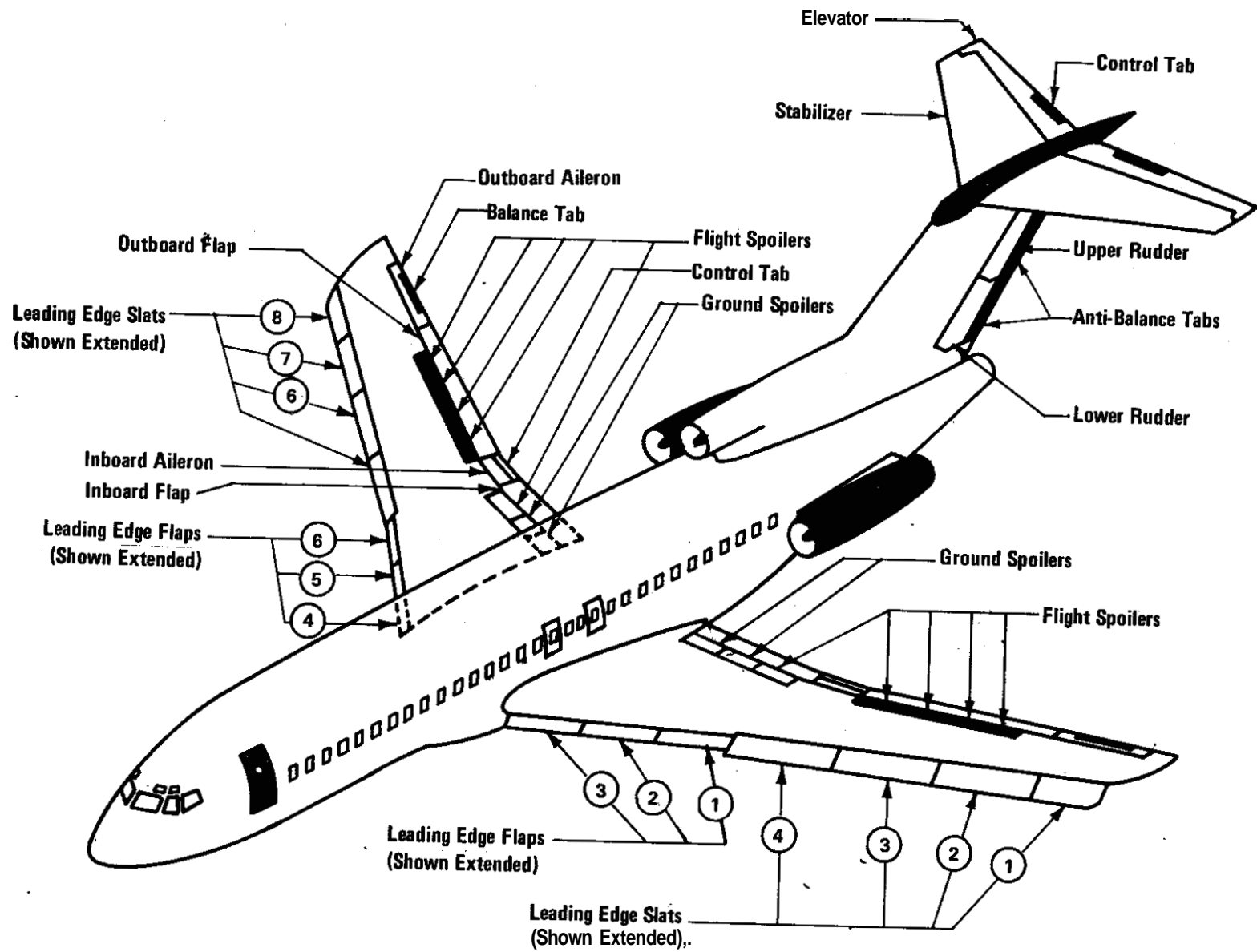
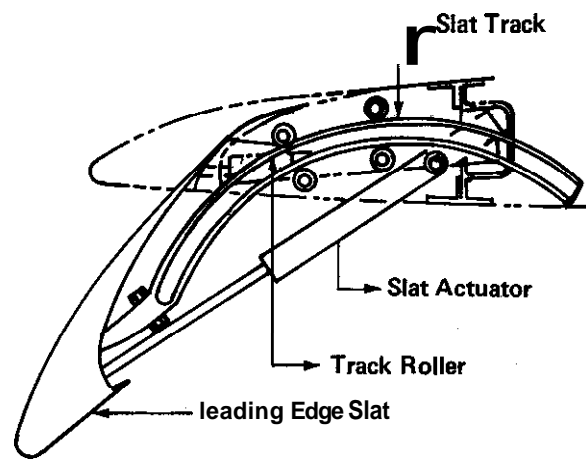
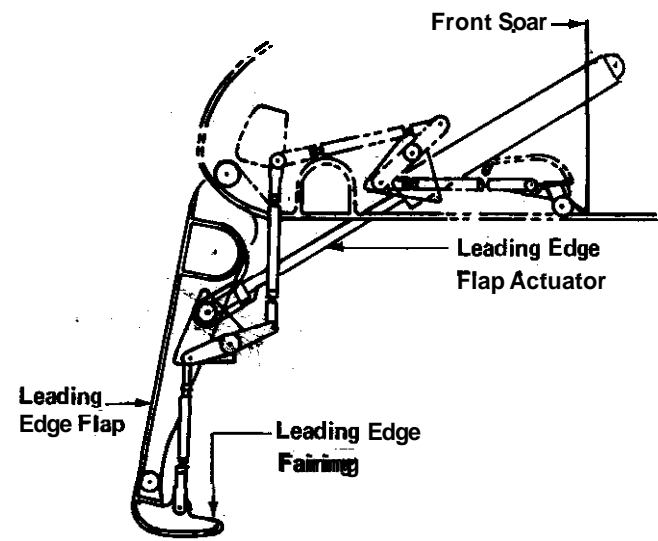

Figure 1.—B-727 flight control system surfaces.



TYPICAL SLAT SECTION



TYPICAL FLAP SECTION

Figure 2.—B-727 wing leading edge devices.

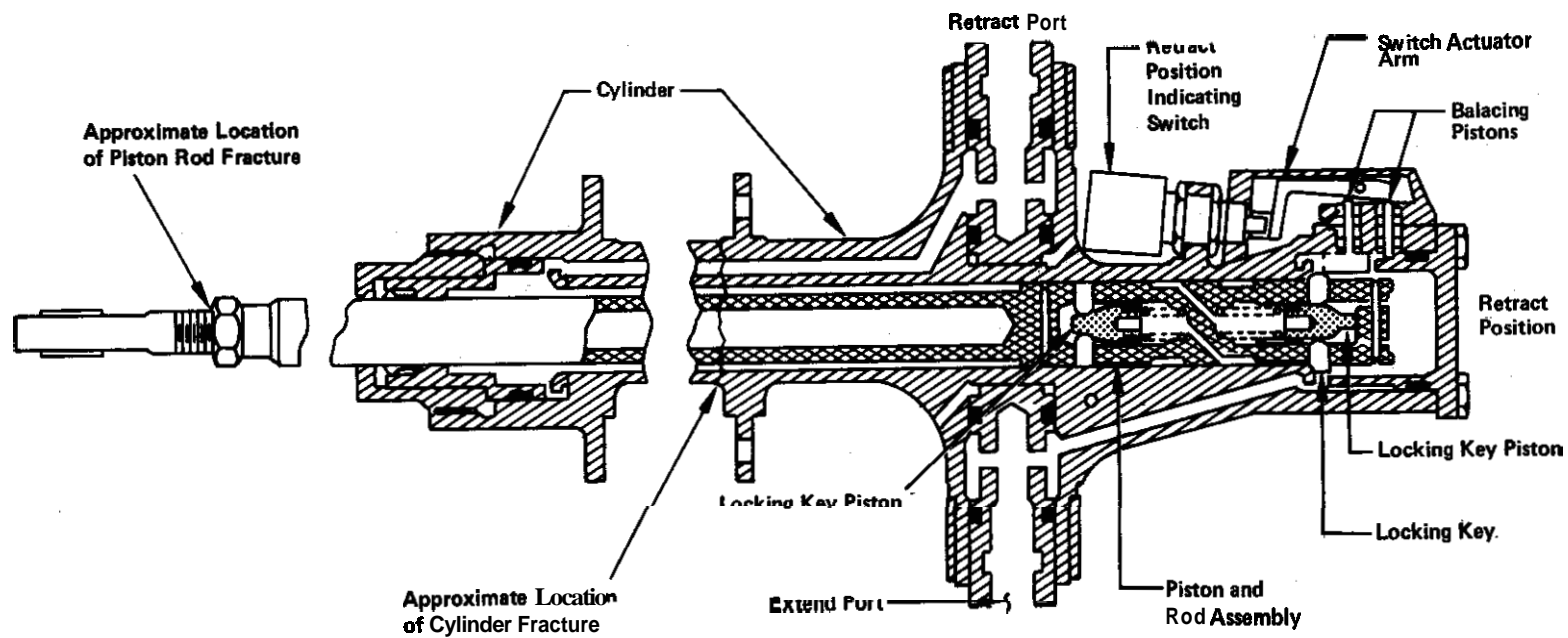

Figure 3.--Leading edge slat' actuator.

1.17.2 History of E727 Leading Edge Slat Problems

According to FAA service difficulty reports (SDRs), from the beginning of 1970 through the end of 1973, seven cases of a single leading edge slat extension and separation on B-727's during flight were reported without mention of whether the extensions were scheduled or unscheduled. In 1974 and 1975, no unscheduled extensions and separations were reported. In 1976, one unscheduled extension without separation was reported; the slat actuator support fitting had broken. No other unscheduled extensions and separations have been reported.

The SDRs contain numerous reports of a leading edge device failing to extend or retract, but these failures were associated with normal extension or retraction schedules. Also, a number of reports attributed the loss of "A" system pressure to a leaking actuator. No uncontrollable flight situations were associated with any of the above failures to extend or retract.

Rec'd. { In 1978, one operator experienced an unintended extension of leading edge devices. While in cruise flight at 25,000 feet and about 350 knots (0.82 mach), the captain detected an airframe vibration which he attributed to a partially extended trailing edge flap. He attempted to retract the trailing edge flap by using the alternate flap system. However, either the retraction switch was moved inadvertently to the "down" position, rather than the "up" position, or the switch was wired backward. In any event, the leading edge devices were unintentionally extended. The leading edge devices were retracted by turning the alternate flap master switch off; however, the No. 6 and No. 7 leading edge slats on the right wing did not retract. The aircraft began to roll and turn to the right, but the captain returned the aircraft to level flight by using left aileron and rudder. The aircraft was kept upright by about 45° of control wheel deflection to the left and by a significant amount of left rudder. After the captain slowed the aircraft, the slats retracted. An unscheduled but normal landing was made as a precautionary measure. The No. 7 slat and the alternate flap retraction switch were changed, and the aircraft was returned to service.

1.17.3 Aircraft Performance

Correlation of FDR information with air traffic control data showed that, after Flight 841 reported level at FL 390 at 2138:44, the FDR vertical acceleration trace remained steady at 1.0 g. At 2147:34, near the Saginaw, Michigan, VOR, while on a steady heading of 288°, the g-trace began to oscillate at an amplitude of about +0.05 g and at a frequency of about 2.0 cycles per second. These oscillations continued—for 70 seconds with the amplitude increasing to a maximum of about ±0.3 g.

After the vertical acceleration trace began to oscillate, the airspeed began to decrease from 245 knots and 10 seconds later it was 240 knots. Also, the heading trace deviated about 1° during the first 6 seconds of the oscillation; it then moved erratically to a heading of about 298° during the following 13 seconds, including an abrupt change of about 5° to the right in 0.5 second, beginning at 2147:45. During the first 19 seconds of g-trace oscillation, the altitude trace decreased from 39,600 feet 5/ to 39,000 feet. From 2147:53 to 2148:04, the altitude decreased to 37,500 feet and the heading trace moved to 184°. During that period, the airspeed increased to 250 knots and the g-trace increased to about 1.7 g's.

5/ Recorder tolerances at 39,000 feet are ± 700 feet.

From 2148:04 to 2148:28, the heading trace moved to 360°, the altitude decreased to about 19,500 feet, the airspeed increased to about 390 knots, and the g-trace increased to 4.0 g's. During the next 17 seconds, the airspeed increased to its maximum value of 470 knots, the altitude trace decreased to its minimum value of about 5,000 feet, and the heading trace moved to about 310°. Also, the g-trace increased to 5.5 g's.

At 2148:51, after having decreased to about 4.5 g's, the g-trace increased rapidly to 6.0 g's; during the following 7 seconds, the g-trace decreased to 1.0 g. At 2148:58, the airspeed was 280 knots and the altitude was 8,500 feet. During the following 27 seconds, the g-trace varied between 1.0 and 0.3 g, the heading trace moved to about 240°, the altitude increased to about 11,300 feet, and the airspeed decreased to about 160 knots.

According to data in the aircraft flight manual, while in cruise flight at 39,000 feet, a gross weight of 130,000 pounds, and about 245 knots indicated airspeed (mach 0.80), Flight 841's maneuvering and performance margins were about 1.37 g's, 70 knots above 1.0 g low speed stall buffet, and 36 knots below 1.0 g high speed (mach) buffet. In smooth air, the aircraft could have sustained level flight at 43° of bank without entering stall buffet.

The FDR airspeeds recorded during Flight 841's descent from 39,000 to about 5,000 feet were converted to mach numbers by applying position error, compressibility, and density altitude corrections. As the aircraft descended, the initial cruise mach number increased to a maximum of 0.96 mach at 31,800 feet and then decreased to 0.78 mach at 10,000 feet and about 0.70 mach near 5,000 feet.

Wing lift coefficients were calculated from FDR airspeed, altitude, and vertical acceleration values. These coefficients fluctuated throughout the descent. High coefficients of 0.7, 0.7, and 1.08 occurred near 39,000, 21,000, and 7,000 feet, respectively. Low values of 0.28 and 0.51 occurred at 30,000 and 16,000 feet, respectively. These lift coefficients were compared to buffet lift coefficients derived from flight test data. The results indicate that Flight 841 was in a high speed buffet throughout most of the descent and recovery to level flight.

Flight 841's flightpath angles during its descent were calculated from indicated airspeed and rate of descent values. These calculations indicated that the aircraft's flightpath angle decreased from zero at 39,000 feet to 90° vertically downward near 29,000 feet. The angle then decreased to about 30° downward at 24,000 feet and then increased to 40° downward as the aircraft descended through about 18,000 feet. The angle then increased further to about 80° downward at 11,000 feet, decreased to zero during the recovery, and increased to about 55° upward during the pullup following recovery. The angle decreased to about zero near 11,000 feet.

The rolling moment coefficients caused by the extension of the No. 7 leading edge slat were supplied by the aircraft manufacturer from wind tunnel and flight test data developed in 1975. These coefficients were compared to the lateral rolling moments available from aileron and spoiler controls at various mach numbers and altitudes as a function of wing angle of attack. The comparison showed that at Flight 841's cruise altitude of 39,000 feet and at a cruise angle of attack of 4°, the rolling moment available from lateral controls at mach 0.80 exceeded the rolling moment caused by the extended slat by a factor of about 2. At 37,000 feet, mach 0.85, and an angle of attack of 5°, the rolling moments were approximately equal. Further increases in the angle of attack or

mach number during the descent generated rolling moments from the extended slat that exceeded those available from the lateral controls. For instance, at a 5° angle of attack, mach 0.90, and 33,000 feet, the rolling moment generated by the extended slat exceeded the moment available from lateral controls by a factor of about 2.4. When the slat was separated from the aircraft's wing, the rolling moments available from lateral controls were dominant.

The manufacturer later provided data to define the critical lateral control margins of the accident aircraft based on assumptions that the right outboard aileron hinge fitting bolt was broken (allowing the aileron to float at its zero hinge moment position) and that the No. 7 leading edge slat extended suddenly to its most adverse position, including the possibilities of deflected and cocked positions. The data were based on the rolling moment coefficient obtained from a flight test data point (at mach 0.80), rather than a wind tunnel test data point.

These data showed that the adverse incremental rolling moment coefficients produced by a floating right outboard aileron were essentially negligible. Also, the data showed that at angles of attack of less than 5° the most adverse position of the slat was its normal extended position. However, the use of the flight test data point (see figure 4) showed that at mach 0.80 and an angle of attack of 4° , the rolling moment coefficient available from lateral controls exceeded the rolling moment coefficient caused by the extended slat by a factor of 1.26, and, that at mach 0.85 at 35,500 feet, the rolling moment coefficients were approximately equal at an angle of attack of 4.8° . Also, by interpolation, at mach 0.83 and an angle of attack of 6° , the moments were approximately equal. Any further increases in either the mach number or angle of attack caused the rolling moment coefficient produced by the extended slat and a floating aileron to exceed the coefficient available from the lateral controls. From the time histories of Flight 841's mach number and angle of attack, it was determined that the rolling moment equalization point occurred 34.5 seconds after the first oscillation of Flight 841's g-trace, or about 2148:07 e.s.t.

Using the adjusted rolling moment data, a dynamic analysis of Flight 841's maneuver was performed. This analysis showed that 12.5 seconds after development of the roll to the right caused by the extended No. 7 slat, the simulated aircraft reached an attitude such that lateral control could not be regained by full deflection of lateral and yaw controls.

1.17.4 No. 7 Leading Edge Slat Operation

The aircraft manufacturer supplied data from the original design wind tunnel and flight tests to determine the forces acting on the No. 7 leading edge slat actuator rod when the slat is retracted. These data showed that, at an equivalent airspeed of 300 knots, the actuator rod would have a compressive load of about 1,400 pounds on it at mach 0.80. Since Flight 841's equivalent airspeed was about 229 knots (245 knots indicated airspeed) at 39,000 feet, rod loads were calculated for these conditions. Calculations showed that at 1.0 g, compressive loads of 700 pounds would act on the rod with the slat retracted. If the g was reduced to 0.70, the compressive load was reduced to 350 pounds. If the g was increased to 1.3 g, the load increased to a compressive force of about 1,000 pounds. Projection of these data showed that to reduce the compressive load on the rod to zero, the load factor would have to be reduced to about 0.35 g. Also, the data showed that, as the slat extends, rod loads decrease and change to tensile loads at about 38 percent of rod extension. Beyond 38 percent extension, the rod is subjected to tensile

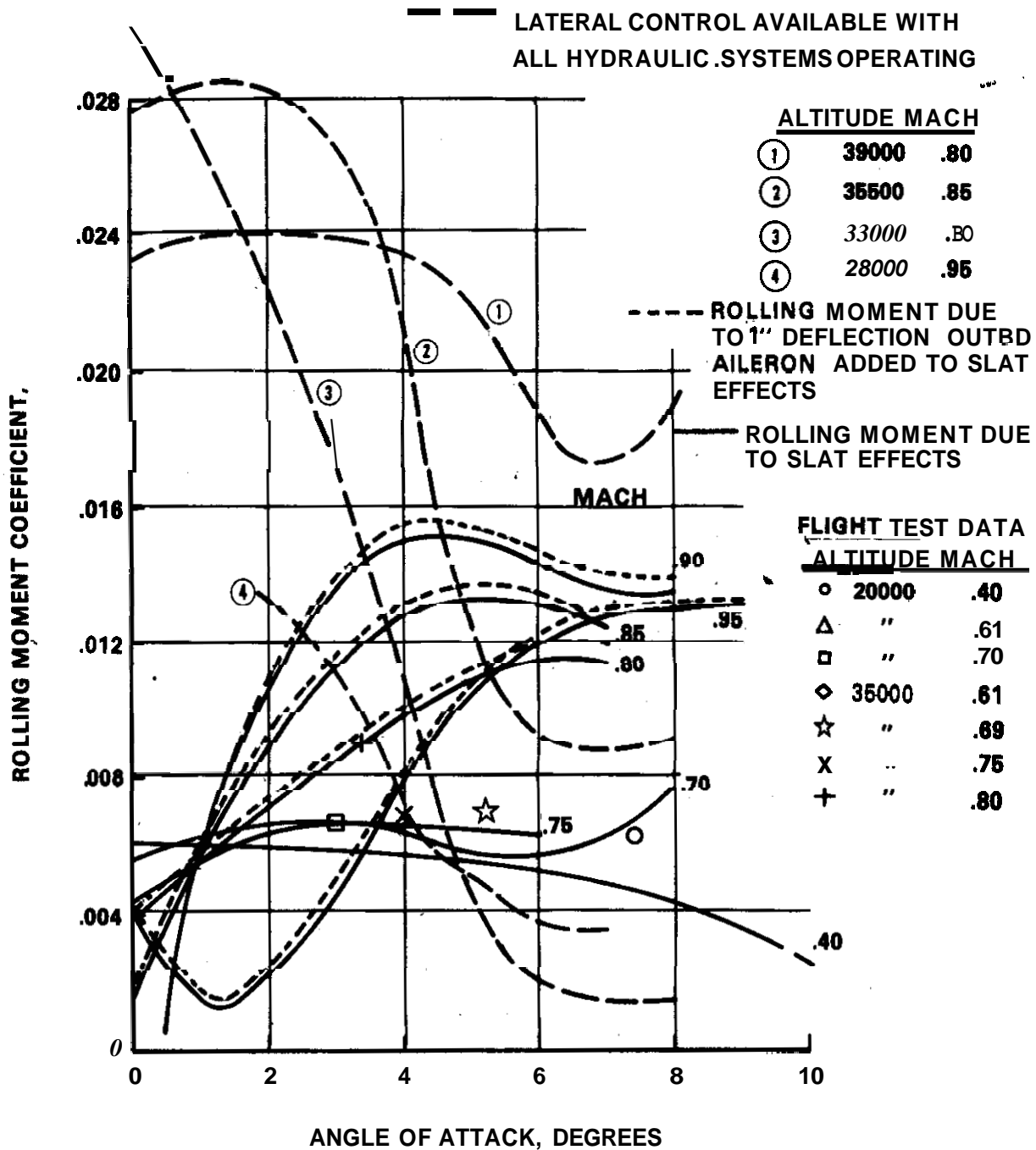

Figure 4.—Rolling moments from extended No. 7 leading edge slat -- adjusted to flight test data points.

loads. At Flight 841's initial conditions, the No. 7 slat actuator rod would have been subjected to a tensile load of about 1,000 pounds with the slat fully extended. At 350 knots equivalent airspeed or higher, the air loads holding the slat extended would exceed 2,400 pounds and the slat could not be retracted because the actuator retraction capacity is 2,400 pounds.

If it is assumed that the right outboard aileron hinge fitting bolt was broken before the No. 7 slat extended, the corresponding aileron float would have produced about a 9 percent reduction in the aerodynamic loads on the No. 7 slat actuator rod. In level cruise flight, this condition would have reduced the compressive load on the rod about 63 pounds.

1.17.5 TWA Flight Operations Safety Bulletin 79-3

On August 6, 1979, TWA issued Flight Operations Safety Bulletin 79-3. The bulletin provided flightcrews with information about B-727 flight characteristics with an extended No. 7 leading edge slat, and it included operational guidance from Boeing OMB 75-7, as revised, concerning an asymmetric slat condition.

1.18 Useful or Effective Investigative Techniques

In an effort to more accurately read PDR foil gtraces when they exhibit high frequency oscillations, a new technique was developed. This technique involved making cellulose impressions of the foil traces and photographing the impressions under high (200 power) magnification. The photographs were then joined and time and amplitude scales were calculated and drawn over the composite traces. This technique permitted the illustration of highly accurate gtrace frequencies and amplitudes on a normal scale. In this manner, it was determined that the high frequency gtrace oscillations associated with airframe buffet on the flight test aircraft's FDR and the accident aircraft's FDR were identical at a frequency of 6 cycles/second and an amplitude of $\pm 0.05g$.

2. ANALYSIS

2.1 The Flightcrew

The flightcrew was properly certificated and was qualified in accordance with existing regulations; however, the captain had requalified in the B-727 only recently and had returned to line flying after having been off duty for about 3 months with a broken ankle. There was no evidence that medical or physiological problems affected their performance. They had a rest period of about 15 hours from the end of their duty on April 3 to the beginning of duty on April 4. This conformed to the requirements of Federal aviation regulations. Additionally, all members of the flightcrew indicated that fatigue was not a factor in their performance.

2.2 weather

Weather was not a factor in the accident.

2.3 The Aircraft

The aircraft was properly certificated and was maintained in accordance with existing regulations and procedures. There were no significant uncorrected discrepancies in the aircraft's maintenance log, and following the "C" check in early March 1979, there were no recorded discrepancies concerning the aircraft's flight control, autopilot, flap, hydraulic, or flight instrument systems.

According to the flightcrew, all systems functioned properly before and after departure from JFK and while en route. The flaps and slats retracted properly and on schedule after takeoff, and the flap/slat position indicating system displayed no abnormal slat or flap condition.

24 Extension of the No. 7 Leading Edge Slat

According to FDR information, about 9 minutes after the aircraft arrived at 39,000 feet, it descended to about 5,000 feet in 63 seconds. The flightcrew could not account for the event that precipitated the aircraft's abnormal descent. The captain, who was flying the aircraft, described the descent as an uncontrollable maneuver involving two rolls to the right, the first of which was preceded by a short period of buzzing and light buffeting of the airframe. According to the captain, everything was normal in the cockpit when the light buffeting began.

Except for the No. 7 slat inboard T-bolt and the right outboard aileron actuator hinge fitting bolt, both of which were broken and showed evidence of preexisting fatigue, the investigation disclosed no significant abnormalities or malfunctions in any of the aircraft's systems. All of the possible sources of uncommanded flight control movements were tested and they functioned properly. The aircraft was operating within its approved performance and maneuvering envelope, and the fuel load was balanced. Also, according to the FDR and the flightcrew, there was no turbulence that might have reduced the aircraft's maneuvering buffet margin, nor were there any significant attitude changes before or during the initial oscillations of the g-trace that would have reduced the aircraft's maneuvering buffet margin. ■ ●

Since there was no evidence of significant abnormalities in the aircraft's systems or flight controls, operating envelope, or environment and, since the No. 7 leading edge slat was missing from the aircraft, the Safety Board focused its investigation on the possibility that an unscheduled extension of the slat might have caused the uncontrollable maneuver. The manufacturer's flight and wind tunnel test data and the flight simulator tests verified that under Flight 841's cruise conditions at 39,000 feet, a right roll develops with the No. 7 leading edge slat in the extended position and with all other leading edge devices retracted. Additionally, these test data established that under certain combinations of mach number and angle of attack, the rolling moments produced by an extended No. 7 slat would exceed counter moments available from lateral controls and the aircraft would become laterally uncontrollable. Flight simulator tests produced two flight maneuvering situations in which control was lost and in which the simulator traces for airspeed, altitude, g, and heading (after correction for heading gyro gimbal errors) reasonably approximated the accident aircraft's FDR traces for these parameters. Simulations of other flight control system malfunctions produced no reasonable correlations with the FDR traces. Although additional heading gyro tests and gimbal error calculations established that one simulated maneuver (double roll reversal) did not reasonably approximate the accident aircraft's heading trace, the data obtained assisted in establishing lateral controllability margins and was useful in determining the aircraft's probable maneuver. I

Based on the physical evidence, aerodynamic data, and the flight simulations, the Safety Board concludes that an extended No. 7 leading edge slat on the aircraft's right wing caused lateral control problems which preceded the aircraft's rapid descent. Additionally, based on the similarities between the accident aircraft's g-trace and the flight test aircraft's g-trace with the Nos. 2, 3, 6, and 7 leading edge slats extended, the Safety Board concludes that the No. 7 leading edge slat on the accident aircraft (and

possibly other slats) began to extend about 2147:32. Also, we conclude that extension of the slat (or slats) created a "buzzing" noise or slight buffet followed by moderate buffet.

Since 1974, the officially recorded history of leading edge slat problems in the B-727 disclosed only one instance of an unscheduled extension of a leading edge slat in flight and one instance of a scheduled extension of multiple slats. All other failures of the slats to extend or retract have occurred during scheduled extensions or retractions. Of the two known instances of slat extensions in flight since 1974, one occurred as a result of an inadvertent but scheduled extension of all the leading edge devices and the other was an unscheduled extension which was caused by a failure of the actuator mount fitting. Neither of these instances resulted in a significant aircraft control problem. Because of the absence of such problems, considerable investigative effort was expended to determine why, out of eight leading edge slats, the No. 7 slat, got isolated in the extended position.

According to the flightcrew, before and immediately after the buzzing began, they saw no lights in the cockpit that indicated an unlocked leading edge device or a failure of a hydraulic system, including the "A" system. Also, the captain stated that there was no inadvertent or deliberate movement of the flap control handle or other controls that would have caused leading edge devices to extend. Therefore, if the flightcrew's recollections are accurate, the No. 7 leading edge slat would have had to extended as a consequence of defects or malfunctions in the No. 7 slat extension/retraction systems.

During the investigation, after repairing and plugging ruptured "A" system hydraulic lines, both the normal and alternate flap control systems were tested. There was no evidence of any malfunction in these systems that might have caused an extension of one or more leading edge devices. Also, the flap/slat indicator system functioned properly--the No. 7 actuating and indicating system could not be checked because the slat was missing, the actuator was broken, and its lines were plugged for the tests.

A fault analysis of the B-727 leading edge slat actuating system indicates that, except for a separation of the piston rod from the actuator piston or a fracture of the piston, at least two failures involving the slat actuator must precede an unscheduled extension of a slat. This is because when the leading edge slat is in the retracted position, the slat actuator piston is held continuously in the locked position by 3,000 psi of "A" system hydraulic pressure and by a mechanical locking device. Therefore, to nullify these features, hydraulic pressure must be lost and the mechanical locking device must fail. There is no evidence that "A" system hydraulic pressure was lost before the slat extended--in fact, the flightcrew statements indicate that it was not lost before the slat extended. Moreover, the landing gear uplocks and the landing gear, which operate off "A" system pressure, retracted and extended respectively, about 72 seconds after the buzzing began. Therefore, any loss or significant reduction of retraction pressure would have had to have involved either a main piston seal failure or a locking piston seal failure. A main piston seal failure would have permitted fluid to flow past the seal to the extend side of the piston, out the return ports, and back into the "A" system reservoir. If the return ports were plugged, the pressure on both sides of the piston could equalize but the locking keys would remain in place from friction and spring pressure. If the locking piston seal also failed, the piston would still maintain its position by friction and spring pressure. Therefore, even a massive leak across either or both piston seals would not have released the mechanical lock.

A locking device failure would have had to involve excessive friction in the switch actuator pin guide while the actuator piston was out of the retract position, thereby freezing the pin in the unlocked position. This condition would have prevented the lock keys from being forced into the lock detent when the actuator piston moved into the retracted position. This condition alone would not have affected slat extension or retraction; however, the amber "in transit" lights on the cockpit displays would have remained illuminated following slat retraction. Therefore, the two concurrent prerequisites for nullification of the hydraulic and mechanical extension restraints would had to have involved a loss of "A" system pressure in conjunction with the freezing of the switch actuator pin in the unlocked position. Both events would have caused warning lights to illuminate in the cockpit.

The forward two-thirds of the actuator cylinder, the actuator piston, the piston rod, the locking pistons, and the locking pins were missing; therefore, the condition of the piston, its seals, and the piston rod could not be verified. However, as described above, it is not likely that even a massive failure of either or both piston seals would have nullified the mechanical lock.

A transverse fracture of the actuator piston would have permitted a maximum differential hydraulic force of about 780 pounds to act on the fractured face of the forward portion of the piston. This force could have extended the No. 7 slat since it was slightly greater than the force produced by air loads on the slat during Flight 841's cruise conditions. However, calculations related to such a fracture in the area of the main piston seal indicate that under normal operational loads, which are predominantly axial, a 11,300 percent margin of safety existed at minimum material strength with regard to internal stress levels that could have produced a fracture in that area. Also, under design limit load conditions, a 3,200 percent margin of safety existed. Further, because of locking piston seal frictional forces, 70 or more g's would have been required to unlock the aft portion of such a fractured piston. Calculations for margins of safety regarding a transverse fracture of the main piston in the area of the retract locking keys, establish that since the cross sectional area of the piston in that location is 59 percent of the main seal cross sectional area, operational and design limit safety margins would have been 6,667 and 1,888 percent, respectively. Also, when in the retracted position, there were no forces acting on the piston that would have tended to produce a transverse fracture in the area of the locking keys. Finally, in 16 years of service history and over 36-million flight hours, such fractures of a slat actuator piston have never occurred. Therefore, the Safety Board concludes that a transverse fracture of the actuator piston was highly improbable.

Even in the remote possibility of one or two failures within the slat actuator that might have nullified both the hydraulic and mechanical restraints, a third condition was necessary to permit an unscheduled extension of the slat. This condition involved aerodynamic loads on the slat that would have produced a tensile force on the actuator piston rod. The evidence indicates that under the aircraft's flight conditions, a compressive force, rather than a tensile force, was acting on the rod when the slat extended.

Based on FDR data and flight test data, the Safety Board concludes that the No. 7 leading edge slat and possibly other slats extended about the time the vertical acceleration trace began to oscillate at an amplitude of about +0.05 g. At that time, the aircraft's equivalent airspeed was about 229 knots (245 knots indicated) and its mach number was about 0.80, and according to the manufacturer's flight test and wind tunnel test data, the airloads on the slat would have subjected the slat actuator rod to a compressive load of about 700 pounds, and about 9 percent less if the right outboard aileron was floating. Moreover, the data indicates that the aircraft's vertical acceleration would had to have decreased from 1.0 to about 0.35 g to reduce the

compressive load to zero. The aircraft's vertical acceleration trace does not show a g-reduction of such a magnitude preceding slat extension. Therefore, the third condition needed for unscheduled extension was not met.

The only reasonable single failure within the slat actuator that would have freed the slat to move in opposition to airloads on the slat was a separation of the piston rod from the actuator piston. Separation of the rod from the piston would have permitted the hydraulic pressure within the cylinder to act on the end of the piston rod with 1,545 pounds of force, which could have forced an unscheduled extension of the slat since the aerodynamic loads on the slat produced less than 1,545 pounds of compressive force on the bearing end of the rod. However, the evidence indicates that the piston rod did not separate from the piston, but rather that the bearing end of the rod fractured in overload and remained attached to the slat. The actuator cylinder was fractured and the retained portion of the cylinder bore was distorted to the extent that the actuator piston could not have been in the retracted position when the cylinder broke; otherwise, the piston would have remained in the retained portion of the cylinder. Therefore, the Safety Board concludes that the piston rod was attached to the piston when the slat extended and when the slat was broken from the aircraft.

A metallurgical examination disclosed that the No. 7 slat inboard T-bolt was significantly weakened by fatigue before it failed. Also, the wear pattern on the slat alignment hooks indicate that the slat was misaligned and that the T-bolt may have broken before the slat extended in flight, causing the inboard end of the slat to sag slightly. The precise aerodynamic effects of such a condition could not be determined. However, since compressive airloads existed on the slat in flight and since the slats retracted properly after takeoff, the Safety Board believes that the loads kept the slat essentially aligned with the leading edge of the wing while the slat was in the retracted position. Under such conditions, it is not likely that the fractured T-bolt caused an aerodynamic problem because the slat tracks and piston rod bear almost all of the slat loads while it is retracted. However, once extended, it is probable that the misalignment caused side and friction loads which, in addition to the high tensile load on the rod, exceeded any available hydraulic force for scheduled retraction.

Postaccident investigation disclosed 1 3/32 inch of free play in the right outboard aileron which was attributed to a broken bolt on the aileron actuator's hinge fitting. A metallurgical examination disclosed that the bolt had also failed predominantly in fatigue. However, it could not be determined when the bolt failed. If it failed before the No. 7 slat extended, the resulting free play would have permitted the aileron's trailing edge to float upward about 1 inch which would have produced a localized reduction in the angle of attack and a resulting loss of lift over the wing area forward of the aileron. According to the aircraft manufacturer, such a loss of lift would have caused a rolling moment to the right which would have required about 13° of control wheel displacement to the left to counter. This amount of deflection would have been noticeable if the bolt had broken any length of time before the No. 7 slat extended. However, even assuming that the bolt broke just before or just after slat extension, rather than later in the maneuver, adding the resulting rolling moment of the free play to the rolling moments generated by the slat, sufficient lateral control would have been available initially to restore and maintain wings-level flight.

The evidence involves a fundamental conflict between the flightcrew's statements and the possibilities and probabilities of an unscheduled extension of the No. 7 slat. Although portions of the slat actuator were not found, the evidence indicates that the possibility of a series of malfunctions and failures occurring which permitted the slat to extend aerodynamically or hydraulically is extremely remote. On the other hand, we

recognize that if the No. 7 slat did not extend as the consequence of some series of failures and malfunctions in the slat system, then it must have been extended as a result of flightcrew action.

After carefully weighing all evidence related to this accident, the Safety Board concludes that there is no evidence of any probable combination of failures and malfunctions in the aircraft's flight control system that would have caused an unscheduled extension of the No. 7 leading edge slat. Moreover, since the airspeed decrease which followed extension of the Nos. 2, 3, 6, and 7 slats during flight tests compares almost exactly with the airspeed decrease experienced by Flight 841 following initial oscillation of its g-trace, which under constant thrust and 1.0-g flight conditions can only be attributed to similar drag producing configurations, the Safety Board concludes that the Nos. 2, 3, 6, and 7 slats were extended as a consequence of flightcrew action. Further, that when scheduled to retract by the flightcrew, the No. 7 slat failed to retract probably because tensile forces created by aerodynamic loads combined with friction and side forces on the piston rod, caused by misalignment of the slat, exceeded the available retraction force.

2.5 Loss of Aircraft Control

All of the pertinent evidence indicates that with the No. 7 slat extended, the B-727 is controllable under Flight 841's cruise flight conditions at 39,000 feet and that the aircraft does not become laterally uncontrollable until certain combinations of mach number and angle of attack are exceeded. These combinations are shown in figure 4, and they represent the lowest values, including the adverse effect of a 1-inch upward float of the right outboard aileron. By interpolation, the lowest combination of mach and angle of attack at which the aircraft was laterally uncontrollable was mach 0.83 and an angle of attack of 6°. These are considered the critical controllability values. When mach number or angle of attack was below these values, the aircraft should have been controllable laterally and when exceeded, the aircraft would have been uncontrollable laterally.

The reason for the lack of controllability when the critical values are exceeded is the severe disruption of airflow and associated loss of lift that occurs over the wing area aft of the extended slat. The loss of lift creates a rolling moment that exceeds the countermoment the pilot can produce with full deflection of lateral controls. The aircraft will respond to the imbalance of rolling moments by rolling uncontrollably toward the wing with the extended slat. By omitting any effects of sideslip, the calculated values of mach number and angle of attack established that the accident aircraft was laterally uncontrollable after 2148:07. At that time, the aircraft's indicated airspeed was about 270 knots (0.83 mach), its altitude was about 36,500 feet, and its rate of descent was in excess of 34,000 feet per minute.

After the No. 7 slat was torn from the aircraft, lateral control was restored and the captain was able to roll the wings parallel to the horizontal and recover from the spiral dive. Simulations of the spiral dive confirmed that loss of the slat restored lateral control and made recovery possible. Also, simulations indicated that although extension of the landing gear significantly reduced the aircraft's speed (and mach number), recovery would have been doubtful without loss of the slat because of the high angles of attack which were developed during the latter part of the descent.

Because of the conflict between the captain's assertions regarding the ineffectiveness of lateral controls and the aerodynamic evidence related to aircraft performance and controllability, significant efforts were made to determine the aircraft's actual motions and performance, as reflected in its FDR traces, subsequent to the first

observed anomalies in the g-trace. These efforts included additional heading gyro tests, extensive calculations of gimbal error associated with heading gyro performance, and flight tests.

Analysis of flight test and flight simulator data indicated that high rates of heading change, such as the 5° in 0.5 second that occurred about 2147:45 in the accident aircraft's heading trace, could not be achieved unless the aircraft was in a banked attitude with high load factors applied. Since the load factor was about 1.0 g at that time, the rapid heading change could not have been associated with turning flight. Also, during flight tests, a full rudder deflection sideslip, when released, did not produce such a rapid heading change, and during sudden extensions of the No. 7 slat in flight simulations, the heading changed comparatively slowly to the right. However, the heading gyro tests and heading gyro gimbal error calculations showed that such an apparent rate of heading change could have been produced by a rapid roll to the left. Consequently, it was hypothesized that during the preceding 12-second period between 2147:33 and 2147:45, the aircraft had rolled to the right.

Based on heading gyro tests and actual heading, bank, and pitch angles recorded during flight simulations of Flight 841's maneuver, it was determined that indicated heading could be accurately calculated by using the standard mathematical equation for heading gyro errors. By use of pitch angles and actual heading angles from the simulations, calculations of gimbal error associated with various bank angles produced an indicated heading trace which was comparable to the accident aircraft's FDR trace with the time shift removed. Calculations of bank angles up to 60° were further confirmed by using aircraft turning performance equations and FDR values of normal acceleration, altitude, and airspeed. These data were programed into the Safety Board's scientific data reduction and plotting computer which drew the results for the first 360° of roll shown in figure 5.

As shown in figure 5, the calculated indicated heading trace for these heading, pitch, and bank angles compares almost exactly with the accident aircraft's FDR heading trace with the time shift removed. Beginning about 2147:34, the aircraft began to roll slowly to the right, and about 6 seconds later, the rate of roll began to increase. At 2147:45, the aircraft was in a right bank of about 35° , after which it was rolled rapidly to the left to near a wings-level attitude. About 2147:47, the aircraft began to roll again to the right, and the roll was arrested briefly at 2147:51 near 3° of right bank. At 2147:53, the aircraft resumed its roll to the right and about 2148:07, the aircraft was inverted with a pitch attitude about 45° below the horizontal. As shown in figure 5, the aircraft's actual heading (calculated) changed comparatively little during the 30° of roll.

Based on flight test data and known times for extension and retraction of leading edge slats, the 12-second period between 2147:33 and 2147:45 was examined to determine whether a compatible relationship existed among slat extension/retraction cycles, slat asymmetry, and calculated angles of bank that were achieved during the period. According to flight tests, buffet begins and is shown in the g-trace about 2 seconds after the beginning of leading edge slat extension. Therefore, it appears that slat extension began about 2147:32. Assuming a reaction time of 2 seconds to retract the slats, retraction would have begun about 2147:39 and would have been completed 5 to 6 seconds later. This would mean that slat asymmetry would have begun about 2147:40 which would have caused an increasing rate of roll to the right while the Nos. 2, 3, and 6 slats retracted. Gimbal error calculations indicate that from 2147:40 to 2147:45 the aircraft rolled from about 10° of right bank to about 3° of right bank at an increasing roll rate. This is compatible with the increasing slat asymmetry that would have occurred during that 5 seconds.

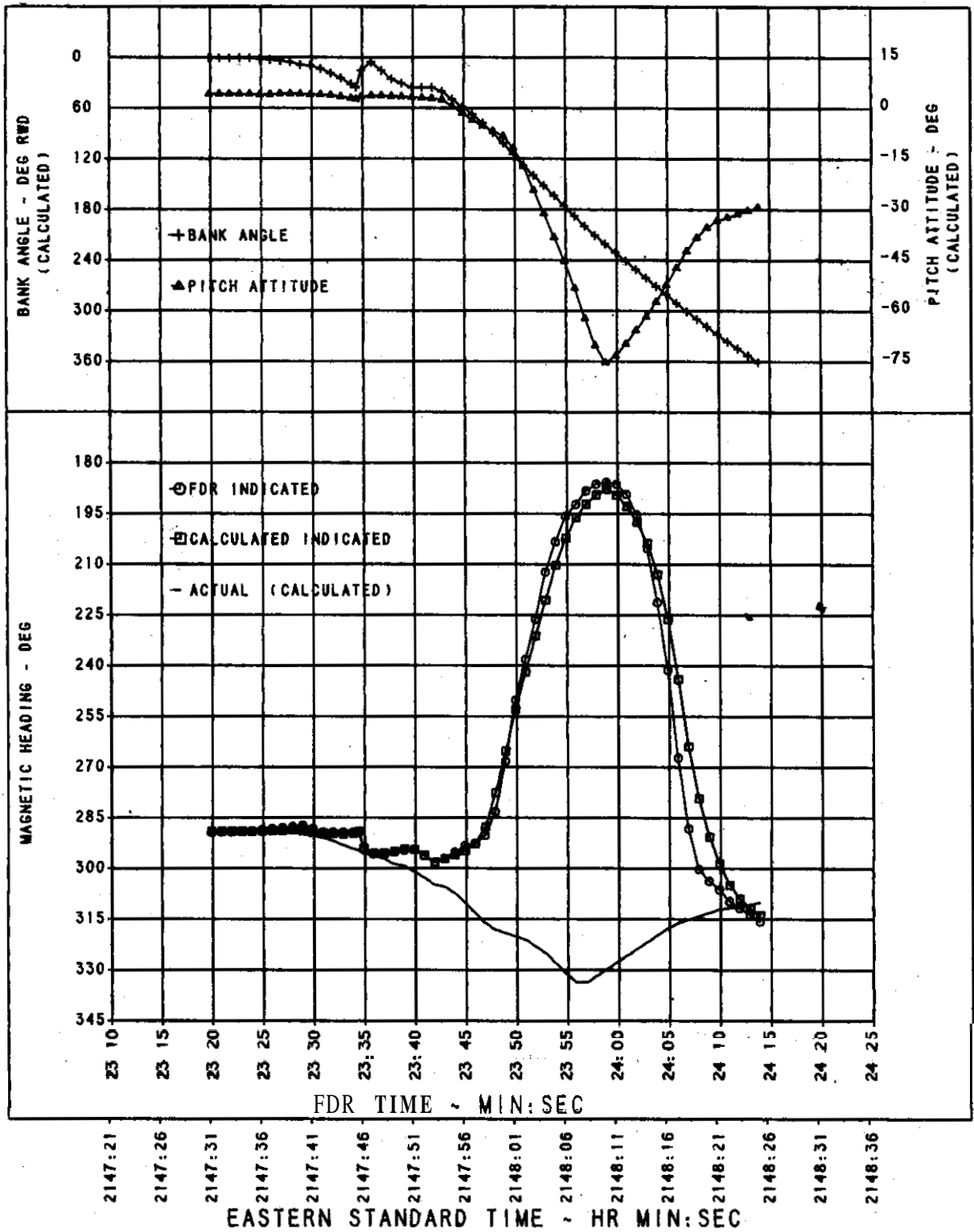

Figure 5.—Comparison of calculated and FDR headings.

Given the foregoing assessment of the aircraft's motions and performance, it is apparent that the aircraft was initially controllable following isolation of the No. 7 leading edge slat in the extended position because, beginning about 2147:45, the aircraft was rolled to the left to a near wings-level position. About 4 seconds later, the aircraft was again banked to the right about 3°. However, following a 2-second pause at 35°, the aircraft resumed its roll to the right and it began to descend rapidly.

The Safety Board is not able to determine conclusively why the captain failed to retain control of the aircraft after having once rolled it from a 3° right bank to near a wings-level attitude. Although we cannot positively exclude spatial disorientation of the captain as a possible reason for his failure to retain control, we believe it more probable that a number of factors combined to place the aircraft in an attitude where critical controllability parameters were exceeded well before the parameters established from subsequent flight simulations of the maneuver. These factors involve the actual effectiveness of the lateral controls, the actual margins of lateral control with an extended No. 7 slat, a cruise mach number that we believe was higher than 0.80, the effects of sideslip induced by full deflection of lateral controls and rudder, and distraction of the captain.

It is possible, for instance, that because of aileron and spoiler rigging tolerances, the accident aircraft had less than specified left roll capability. Although these tolerances would not have been noticeable in normal maneuvering flight, they could have become a factor during full deflection of the controls. Also, it is possible that lateral control margins were reduced to values similar to those shown in figure 4, rather than the higher values used in the flight simulations.

The Safety Board believes that Flight 841's cruise mach number at 39,000 feet pressure altitude probably was higher than 0.80. Support for a higher cruise mach number is indicated by a comparison of the airspeed and altitude traces with the captain's statements about mach number and airspeed. He said that he climbed the aircraft from 35,000 to 39,000 feet at 0.80 mach and leveled at 39,000 feet at 0.80 mach. According to the FDR, when the aircraft was leveled at 39,000 feet its indicated airspeed was 240 knots. However, at that pressure altitude, indicated airspeed must be 247.5 knots to achieve 0.80 mach. Consequently, it appears that the recorded airspeed was 7.5 knots too low but within recorder tolerances of +10 knots. The captain also stated that just before the buzzing began the indicated airspeed was 252 knots. At that time, the recorded airspeed was about 245 knots which tends to confirm a recorder error of -7.5 knots. At an indicated airspeed of 252 knots at 39,000 feet, the aircraft would have had to have been at mach 0.816, rather than 0.80. Additionally, when the -7.5 error is accounted for during Flight 841's maneuver, higher mach numbers were achieved than those originally calculated and, at certain times, the aircraft would have been closer to its critical controllability mach number than was originally calculated.

Under conditions of slat asymmetry and high mach numbers, the effects of sideslip on lateral stability and control can be significant even though the aircraft is well below its freestream critical controllability mach number. For instance, at a freestream mach number of 0.83, 6° of angle of attack, and 0° of sideslip, the local critical controllability mach number at the leading edge of the No. 7 slat (extended) is 0.688 because of the 3° sweep angle of the wing. If a 5° right sideslip is introduced, the local critical mach number is reached at a freestream mach number of 0.787. Consequently, with the introduction of sideslip, the accident aircraft could have reached critical controllability parameters at freestream mach numbers significantly below the critical values for 0° of sideslip.

Flight test data and flight simulations indicated that in the B-727 full deflection of lateral controls and full deflection of rudder in the same direction can produce sideslip angles of 4 to 6.5°. Also, flight tests in conditions similar to Flight 841's at 39,000 feet showed that rolls with full deflection of the lateral controls produced sideslip angles of about 5° in the direction opposite to the roll. As shown in figure 5, about 2147:47, after a left roll to a near wings-level position, the aircraft again began to roll to the right and about 4 seconds later was at 3° of right bank where the roll was checked for a few seconds. Under the circumstances, we believe this roll probably occurred while the captain was distracted by activities related to the No. 7 slat having been isolated in the extended or partially extended position. Thereafter, if full lateral and rudder controls were applied simultaneously or in rapid succession to stop the roll, significant sideslip could have been introduced at a critical time, and the aircraft could have become laterally uncontrollable well before its 0° sideslip controllability parameters were reached.

Calculations of mach number and angle of attack, which take into account a recorder error of -7.5 knots and the effects of roll rate on angle of attack, indicate that at 2147:51, the accident aircraft was at mach 0.79 and an angle of attack of 5.7°. Also, according to gimbal error calculations, the aircraft was banked about 3° to the right. Under these conditions, if a 48° right sideslip angle was introduced, lateral control could have been lost. About 2147:54, the aircraft's rate of descent began to increase very rapidly, although FDR indicated airspeed was stable at 236 knots, which indicates that thrust was substantially reduced or drag was substantially increased shortly before that time. According to the captain, he reduced the throttles to flight idle well before he extended the speed brakes. Consequently, the Safety Board believes that shortly before 2147:54, the captain removed his right hand from the control wheel and used his right hand to retard the throttles to flight idle. Moreover, we believe that the aircraft was then in a substantial sideslip condition which, perhaps in conjunction with some relaxation of the lateral controls or less than optimum left roll authority, caused the aircraft to exceed its critical controllability parameters and to roll uncontrollably into a rapid spiralling descent.

As stated before, we are not able to fully explain why the loss of control occurred. However, we note that the foregoing explanation is consistent to some degree with the captain's statements about his manipulation of flight and throttle controls. Also, we believe that under the circumstances, after having apparently controlled the initial roll to the right, it would not have been unusual for the captain to have diverted his attention from the flight instruments to other instruments and controls in an effort to determine the cause of the initial roll and the cause of the continuing airframe buffet, particularly since the other crewmembers apparently were not aware initially of the aircraft's condition.

As shown in figure 5, the second roll to a 35° right bank occurred in about 4 seconds—a comparatively brief period in which even a slight distraction could have been critical. At the conclusion of the 4 seconds, the roll was stopped for a few seconds which indicates that lateral controls probably were applied quickly and fully in response to the comparatively rapid rate of roll. Since the captain followed the application of lateral controls with a significant amount of rudder, as indicated by his statements, we conclude that a sideslip condition was generated which placed the aircraft in a laterally uncontrollable condition as evidenced by the resumption of the roll to the right. Further, it is possible that cocking or deflection of the No. 7 slat added to rolling moment imbalance at this critical point. Thereafter, the speeds and angles of attack generated by the rapid descent and high g-forces combined with the extended No. 7 slat to keep the aircraft in an uncontrollable condition until the slat was torn from the wing.

During the investigation, questions were raised about why the flightcrew might have extended the leading edge slats under the existing operating conditions. Several theories were considered, including accidental actuation of the flap lever, maloperation of the alternate flap system and an unsuccessful attempt to extend trailing edge flaps independently of leading edge slats, possibly in an effort to improve aircraft performance.

The flightcrew denied having moved any controls that would have caused extension of flaps or slats. Since there is no other available evidence of flightcrew activities in the cockpit, the Safety Board is not able to determine conclusively why the Nos. 2, 3, 6, and 7 leading edge would have been extended. However, we note that since the flap lever must be moved up and over a gate before it can be moved to a flap/slat extension position, it is not likely that the lever was moved accidentally. Further, since operation of the alternate flap system to extend leading edge devices results in random and initially unsymmetrical extension of leading edge flaps and slats, extension of only the Nos. 2, 3, 6, and 7 slats would not have been likely.

*NTSB
2011/11/18* In summary, the Safety Board concludes that the following sequence of actions and events probably occurred to cause Flight 841 to enter an uncontrollable spiral dive involving two 360° rolls and a loss of about 34,000 feet of altitude in about 63 seconds:

- o While cruising at mach 0.816 and 39,000 feet pressure altitude and with the autopilot controlling the aircraft, an attempt was made to extend 2° of trailing edge flaps independently of the leading edge slats, probably in an effort to improve aircraft performance.
- o The attempt to independently extend 2° of trailing edge flaps was not successful, and about 2147:32 the Nos. 2, 3, 6, and 7 leading edge slats began to extend. Two seconds later, the aircraft began to buffet and roll slowly to the right. Six to seven seconds later, the rate of roll began to increase due to increasing slat asymmetry as the Nos. 2, 3, and 6 slats retracted. The No. 7 slat failed to retract.
- o About 2147:45, the aircraft reached about 3° of right bank where the captain disconnected the autopilot and rapidly rolled the aircraft to the left to a near wings-level attitude. The aircraft could have been stabilized in wings-level flight with appropriate deflection of the lateral controls.
- o About 2147:47, the aircraft again began to roll to the right, probably while the captain was distracted by activities related to the isolation of the No. 7 slat in the extended position.
- o Shortly before 2147:51, the captain recognized the rapid right roll, and he rapidly applied full deflection of the lateral controls to stop the roll. The roll was stopped near 3° of right bank for several seconds during which the captain removed his right hand from the control wheel, pulled the throttles to flight idle, and deflected full or nearly full left rudder (to augment lateral controls).
- o In response to the rapid and full or nearly full deflection of the flight controls, the aircraft entered a substantial right sideslip. The sideslip combined with the aircraft's mach number and angle of attack to reduce the lateral control margin to zero or less. The

(aircraft resumed the right roll and began to descend rapidly and uncontrollably. The captain extended speed brakes, detected no reaction, and retracted them.

- o About 2148:25, the aircraft completed 360° of roll while descending to about 21,000 feet. Shortly thereafter, the captain commanded landing gear extension which was accomplished by the first officer. The aircraft continued to descend rapidly, and it continued to roll to the right until the No. 7 slat was torn from the wing and lateral control was restored. About 2148:58, the captain regained control of the aircraft at an altitude of about ~~2,000~~ 5,000 feet.

Since our weighing of the evidence involves a rejection of the possibility of an unscheduled extension of the No. 7 slat and a partial rejection of the captain's recollection of his actions following extension of the slats, the Safety Board believes that the following comments are appropriate: We believe the captain's erasure of the CVR is a factor we cannot ignore and cannot sanction. Although we recognize that habits can cause actions not desired or intended by the actor, we have difficulty accepting the fact that the captain's putative habit of routinely erasing the CVR after each flight was not restrainable after a flight in which disaster was only narrowly averted. Our skepticism persists even though the CVR would not have contained any contemporaneous information about the events that immediately preceded the loss of control because we believe it probable that the 25 minutes or more of recording which preceded the landing at Detroit could have provided clues about causal factors and might have served to refresh the flightcrew's memories about the whole matter. ■ ●

3. CONCLUSIONS

31 Findings

1. The flightcrew was properly certificated and was qualified for the flight; the captain had requalified in the B-727 only recently, had flown 21 hours 50 minutes since requalifying, had not flown for about 3 months before requalification, and had flown exclusively as a first officer on B-747's from November 1977 to December 1978.
2. The aircraft was certificated and maintained in accordance with existing regulations and procedures.
- ~~3.~~ The inboard slat track T-bolt on the No. 7 leading edge slat had failed predominantly in fatigue.
- ~~4.~~ The right outboard aileron actuator hinge fitting bolt rib had failed predominantly in fatigue.
- ~~5.~~ The wear pattern on the slat alignment hooks indicated that the No. 7 leading edge slat was not aligned properly.
6. There was no other evidence of irregularity, malfunction, or failure of the aircraft's flight control, autopilot, hydraulic, or flap systems that might have caused or contributed to a lateral control problem.

7. The aircraft's **gross** weight and center of gravity were within the authorized performance and maneuvering envelopes when a lateral control problem developed.
8. The aircraft was cruising at **0.816** mach in level flight and smooth air at **39,000** feet when a lateral control problem developed.
9. A failure of the right outboard aileron actuator hinge fitting bolt before development of the lateral control problem would have permitted the aileron to float upward about **1** inch; this condition would have required about **13"** of left deflection of the control wheel to maintain wings-level flight and would have been noticeable.
10. A right roll and a lateral control problem were caused by isolation of the **No. 7** leading edge slat in the extended position.
11. There was no evidence of any combination of failures or malfunctions in the aircraft's flight control system that would have caused an unscheduled extension of the **No. 7** leading edge slat.
12. The **Nos. 2, 3, 6, and 7** leading edge slats were scheduled to the extended position, and the **Nos. 2, 3, and 6** slats were retracted as a consequence of the flightcrew's actions.
13. When scheduled to retract, the **No. 7** leading edge slat failed to retract probably because tensile forces created by air loads combined with friction and side forces on the piston rod, caused by preexisting misalignment of the slat, exceeded the available hydraulic retraction force.
14. The **No. 7** leading edge slat in the extended position created rolling moments to the right that could have been countered with about **46°** of control wheel deflection to the left; an additional **13'** of control wheel deflection would have been needed to counter moments associated with a 1-inch upward float of the right outboard aileron.
15. After recognizing the right roll condition, the captain rolled the aircraft to a near wings-level upright position; thereafter, through untimely use of the flight controls, he permitted the aircraft to roll to the right into an uncontrollable attitude. The captain probably **was** distracted immediately after restoring the aircraft to near level flight by his efforts in attempting to rectify the source of the control problem.
16. The captain probably induced sideslip shortly before **2147:54** when the aircraft was at mach **0.79**, an angle of attack of **5.7°**, and an angle of bank of about **35°** to the right. A sideslip angle of **4.8°** to the right could have caused the aircraft to become laterally uncontrollable.

17. The aircraft descended in a spiral dive from 39,000 to about 5,000 feet in 63 seconds; during the descent, the aircraft's speed increased to a maximum speed of about 0.96 mach at 31,800 feet.
18. When the aircraft's speed exceeded 0.83 mach and its angle of attack exceeded 6° near 36,500 feet, the rolling moments caused by the extended No. 7 slat substantially exceeded the maximum available lateral control authority at 0° of sideslip.
19. The aircraft was not controllable during its descent below about 36,500 feet until the No. 7 leading edge slat separated from the right wing.
20. Vertical acceleration forces increased throughout the spiral descent to a maximum of about 6.0 g's during the recovery.
21. The accident was survivable.
22. Minor injuries to passengers were caused by the g-forces.

32 Probable Cause

The Safety Board determines that the probable cause of this accident was the Isolation of the No. 7 leading edge slat in the fully or partially extended position after an extension of the Nos. 2, 3, 6, and 7 leading edge slats and the subsequent retraction of the Nos. 2, 3, and 6 slats, and the captain's untimely flight control inputs to counter the roll resulting from the slat asymmetry. Contributing to the cause was a preexisting misalignment of the No. 7 slat which, when combined with the cruise condition airloads, precluded retraction of that slat. After eliminating all probable individual or combined mechanical failures or malfunctions which could lead to slat extension, the Safety Board determined that the extension of the slats was the result of the flightcrew's manipulation of the flap/slat controls. Contributing to the captain's untimely use of the flight controls was distraction due probably to his efforts to rectify the source of the control problem.

4. RECOMMENDATION

On January 21, 1980, the National Transportation Safety Board issued the following recommendation to the Federal Aviation Administration:

Disseminate to all B-727 operators and flightcrews information of the type included in Boeing Operations Manual Bulletin 75-7 and Trans World Airlines Flight Operations Safety Bulletin 79-3 which address control problems associated with high-speed asymmetrical leading edge slat configuration on B-727 aircraft. (Class II, Priority Action) (A-80-8)

In a letter dated April 18, 1980, the FAA declined to take any action on the recommendation. In a letter dated June 20, 1980, the Safety Board disagreed with the FAA's position, and the FAA responded by letter dated December 18, 1980, that no action would be taken pending an evaluation of the flight test data acquired in October 1980 and the Safety Board's final report of the accident.

BY THE NATIONAL TRANSPORTATION SAFETY BOARD

/s/ ELWOOD T. DRIVER
Vice Chairman

/s/ FRANCIS H. McADAMS
Member

/s/ G. H. PATRICK BURSLEY
Member

FRANCIS H. McADAMS, Member, filed the following concurring and dissenting statement:

Although I voted to approve the Board's report which concluded that the extension of the leading edge slat was due to flightcrew action, I do **so** reluctantly.

The report as written, based on the available evidence, i.e., the analysis of the flight data recorder, the simulator tests, the flight tests, and the tilt table tests, appears to support the Board's conclusion. However, I am troubled by the fact that the Board has categorically rejected the crew's sworn testimony without the crew having had the opportunity to be confronted with **all** of the evidence upon which the Board was basing its findings. At the time of the first deposition, the following evidence was not available to the crew or to the Board: the flight data recorder analysis, the results of the simulator and flight tests, and the tilt table tests. Although the crew was deposed a second time, their testimony was limited to one issue, i.e., the physical location of the flight engineer at the time of the incident. I had recommended that since the Board was ordering a second deposition it be conducted de novo so that the crew would have been aware of **all** the evidence. The Board did not agree.

Furthermore, I do not agree that a probable cause of this accident, as stated by the Board, was "the captain's untimely flight control inputs to counter the roll resulting from the slat asymmetry." In my opinion, the captain acted expeditiously and reasonably in attempting to correct for the severe right **roll** condition induced by the extended slat.

JAMES B. KING, Chairman, and PATRICIA A. GOLDMAN, Member, did not participate.

June 9, 1981

5. APPENDIXES

APPENDIX A

INVESTIGATION AND HEARING

1. Investigation

The Safety Board was notified of the accident about **0200** on April 5, 1979. An investigator from the Chicago, Illinois, Field Office was sent immediately to Detroit, Michigan; operations, systems, and structures investigators were sent from the Headquarters office. Later, investigative responsibility for the accident was transferred to the Safety Board's Headquarters in Washington, D.C.

Representatives from the Federal Aviation Administration, Trans World Airlines, Inc., Boeing Company, and the Air Line Pilots Association participated in the investigation.

2. Public Hearing

There was no public hearing. The flightcrew was deposed in Los Angeles, California, on April 12, 1979. Two FAA inspectors, three flight attendants, and the flightcrew were deposed in Kansas City, Missouri, on January 29, 1980.

APPENDIX B

PERSONNEL INFORMATION

Captain Harvey G. Gibson

Captain Gibson, 44, was employed by Trans World Airlines, Inc., on December 9, 1963. He holds Airline Transport Pilot Certificate No. 1192040 with an airplane multiengine land rating and type ratings in the DC-9, B-727, B-747, L-1011, and commercial pilot privileges for airplane single engine land, rotorcraft-helicopter, and balloons. His first-class medical certificate was issued March 7, 1979, with no limitations.

Captain Gibson advanced to captain on February 13, 1969. At the time of the accident, he had accumulated about 15,710 flight-hours, 2,597 of which were in the B-727. From November 1977 to December 1978, Captain Gibson flew as a first officer on B-747 aircraft. Before that period, he flew as first officer on B-707, L-1011, and B-747 aircraft. Periodically, he also flew as a captain in DC-9 and B-727 aircraft.

First Officer Jess S. Kennedy

First Officer Kennedy, 40, was employed by Trans World Airlines, Inc., on December 9, 1969. He holds Commercial Pilot Certificate No. 1541716 with airplane single engine land, multiengine land, and instrument ratings. He also holds Flight Engineer Certificate No. 1752787, limited to turbojet powered aircraft. His first-class medical certificate was issued October 17, 1978, with the limitation that he wear glasses while flying.

First Officer Kennedy qualified as a flight engineer on B-727 aircraft on April 28, 1967, and he qualified as a first officer on B-727 aircraft on March 3, 1969. At the time of the accident, First Officer Kennedy had accumulated about 10,336 flight-hours, 8,348 of which were in the B-727. He completed annual ground school and a simulator check in December 1978. His last line check was completed on September 20, 1978.

Second Officer Gary N. Banks

Second Officer Banks, 37, was employed by Trans World Airlines, Inc., on September 26, 1969. He holds commercial Pilot Certificate No. 1549011 with airplane single engine land, multiengine land (centerline thrust only), and instrument ratings. He holds Flight Engineer Certificate No. 1978493, limited to turbojet powered aircraft. His first-class medical certificate was issued August 24, 1978, with no limitations.

At the time of the accident, Second Officer Banks had accumulated about 4,186 flight-hours, 1,186 of which were as a flight engineer on the B727. He completed a simulator check on November 23, 1978, and a line check on May 18, 1978.

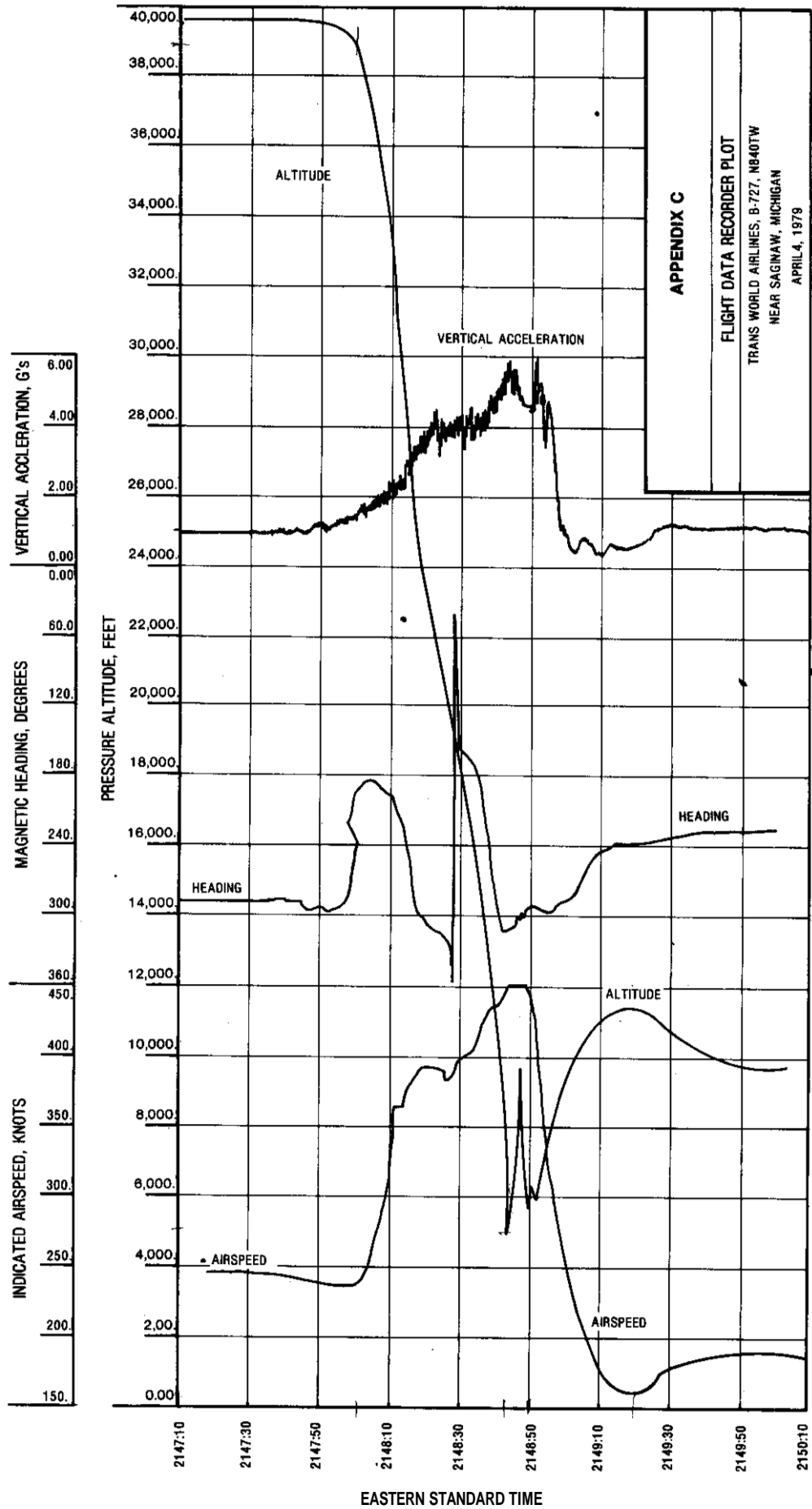

APPENDIX C
FLIGHT DATA RECORDER PLOT
TRANS WORLD AIRLINES, B-727, N840TW
NEAR SAGINAW, MICHIGAN
APRIL 4, 1978

34000

APPENDIX D

TRANSCRIPT OF FAIRCHILD A-100 CVR,
S/N 829, REMOVED FROM TWA BOEING 727

LEGEND

CAM Cockpit area microphone voice or sound source

RADO Radio transmission from accident aircraft

-1 Voice identified as Captain

-2 Voice identified as First Officer

-3 Voice identified as Flight Engineer

-? Voice unidentified

FD Fire Department

CR Company (TWA) ramp operations ,

* Unintelligible word

Nonpertinent word

% Break in continuity

O Questionable text

(()) Editorial insertion

-- Pause

Note: **All** times are expressed in elapsed time from an arbitrary origin.

INTRA-COCKPIT

TIME &
SWRCE

CONTENT

((Beginning of recording following bulk erase))

3:20
CAM-1

(Well the) nose gear door

CAM-? What's the ramp frequency here?

CAM-3 Ah, he's right, he wouldn't know,
1'11 (get it)

CAM-3 Detroit one twenty nine one

CAM-? I wonder if there's anybody in there

CAM-? Ah, I hope so

AIR-(;ROUND COMMUNICATIONS

TIME &
SOURCE

CONTENT

4:00
FD

Hello cockpit

4:07
R00-?

Yeah

F0

Ah, did you call operations and
request a bus?

R00-?

No, hut we ~~vw~~

rn

Okay, thank you

4:19
R00-?

What's the frequency

INTRA-COCKPITTIME &
SOURCECONTENTAIR-GROUND COMMUNICATIONSTIME 6
SOURCECONTENT

RW-? Ah ramp TWA, this is eight forty one

CR Yeah go ahead

RDO-? Ah we've been asked to deplane the passengers, ah, because of a slight fuel leak here

RW-? The fire department has asked us to get 'em off and ah we'd like some kind of transportation a bus for then. please

RDO-? What we're going to do Is drop the aft stairs and let them walk off ah without excitement, we just want to get them off easily, but we need to get them out of off the taxiway here

CR Yeah. are you still, you still on the runway or?

RDO-? No we're on a turnoff from the runway. we're clear of the runway

CR Okay, we'll see what we can do here, is there any way that you can keep in contact with us here?

INTRA-COCKPIT

TIME &
SOURCE

CONTENT

5:25
CAM ((Sound of seat movement))

CAM-? Want help

CAM-? Well we won't need that any more

CAM-? (Looks like) a hydraulic fluid loss
huh • •

CAM-? That's what we were told • •
hydraulic •

CAM-? Old you feel kind helpless in that
seat back there

CAM-? Well. I'll tell you

CAM-? (Believe me)

CAM-? Yeah

CAM-? (Definitely)

CAM-? You know it's funny to be back here
trying to analyze -- this situation

AIR-GROUND COMMUNICATIONS

TIME &
SOURCE

CONTENT

RW-? Ah, I'm talking to you from the
airplane right now

CR I mean can you stay on this frequency
though

5:25
RW-? Yes I can

INTRA-COCKPIT

TIME 6 SOURCE	<u>CONTENT</u>
CAM-?	Yeah
CAM-?	If it happened here, hard to see what's happening. you guys were trying to pull it up
CAM-?	Yeah
CAM-?	Saying get it up, pull it up, like
CAM-?	That's ah --- emergency descent. as a flyer who wasn't flying it
CAM-?	(Thing) did all right, well done
CAM	((Sound of cough))
CAM-?	What are you eating, you got one of those cough drops
CAM-?	Huh, yeah by # I ah, yeah
CAM-?	Oy #, I could eat the * (right out of the) • • okay
CAM-?	Son of a gun
CAM-?	• • I'll get you one
CAM-?	Throat a little dry
CAM-?	Yeah a little dry and my mouth's a little, a little dry
8:30 CAM-3	Okay, I'll stay here to stay on the radio

AIR-GROUND COMMUNICATIONS

TIME 6 SOURCE	<u>CONTENT</u>
------------------	----------------

INTRA-COCKPIT

<u>TIME & SOURCE</u>	<u>CONTENT</u>
CAM-?	* *
CAM-?	* *
CAM-?	* *
CAM	((Above conversation sound as if in main cabin))

AIR-GROUND COMMUNICATIONS

<u>TIME & SOURCE</u>	<u>CONTENT</u>
9:15 CR	Eight forty one from Detroit ramp
R00-?	TWA's eight forty one, go ahead
9:20 CR	Yes sir, looks like your pretty close to Eastern's terminal there, you think its conceivable that we can walk the people over there, I'm gonna have a hard time gettin' a bus
9:26 R00-3	Okay. if you could bring somebody over as a guide, I thing that would be fine, they wouldn't mind walking that far
CR	We'll do that.

<u>INTRA-COCKPIT</u>		<u>AIR-GROUND COMMUNICATIONS</u>	
<u>TIME & SOURCE</u>	<u>CONTENT</u>	<u>TIME & SOURCE</u>	<u>CONTENT</u>
CAM-3	Okay. what they intend to do is they cannot get a bus so they're going to bring a guide out and walk them to the Eastern terminal		
CAM-3	Ah, whichever one of these it is but in any case they're going to walk them		
CAM-?	• • they won't let them on the airplane		
9:53 CAM-?	What's that?		
CAM-?	They won't leave them on the airplane		
CAM-3	No, I don't imagine they wr now that they're off		
10:00 CAM-3	Do you want me to call them back and see about that?		
CAM-1	Oh, no • *		
CAM-2	Hoot		
CAM-1	Yeah		
CAM-?	* * for all the help the people did great, they did exactly what they were told to do		

INTRA-COCKPIT

<u>TIME & SOURCE</u>	<u>CONTENT</u>
10:15 CAM-3	That's because you guys took over and did it
CAM-?	There were times on there when I had problems (just looking to see if it was over with • *
CAM-?	* *

AIR-GROUND COMMUNICATIONS

<u>TIME & SOURCE</u>	<u>CONTENT</u>
RDO-3	Ah, ramp TWA's eight forty one
CR	Go ahead
RDO-3	Do you need a, any further contact here. if not 1'11 turn the radios off
CR	Ah. no except. ah. can you give me anything, any indication on the airplane or anything dispatch, planning and everybody else is calling, ah can. is there any information that you can give me
10:37 RDO-3	No sir, we can't I'm sitting in the cockpit and I can't tell you. I don't know what the situation is ,you'll have to talk to maintenance

INTRA-COCKPITTIME &
SOURCECONTENT

CAM-? * *

AIR-GROUND COMMUNICATIONSTIME &
SOURCECONTENT

CR Yeah well I mean ah. you lost hydraulic *is* that it?

10:54
RDO-3 We ~~we~~ assume that's what happened but we can't tell you that what I say until (you) talk to maintenance

11:00
CR Okay. you can sign off then

11:08
RDO ((Sounds of electrical interruption))

11:43
RW-? Detroit ramp do you read?

11:52
RDO-? Detroit ramp to you read?

12:26
RDO ((End of recording))

APPENDIX E

BOEING OPERATIONS MANUAL BULLETIN 75-7

OPERATIONS MANUAL BULLETIN

THE BOEING COMPANY, SEATTLE, WASHINGTON 98124

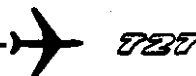

DOCUMENT
EFFECTIVITY: ALL BOEING 727 OPERATORS

NUMBER: 75-7 (Revised)
DATE March 10, 1976

SUBJECT: Leading Edge Slat Actuator Lock Rings

REASON TO provide Flight Crew Personnel with temporary operational information in the event a leading edge slat actuator lock ring malfunction occurs or is suspected.

This Bulletin is issued as the need arises for alert information which requires prompt distribution. It is distributed to Operations Manual holders and to others who need early advice of changes to procedural and training information.

Information in this bulletin is recommended by The Boeing Company, but may not be FAA approved at the time of writing. In the event of conflict with the FAA approved Airplane Flight Manual (AFM), the AFM shall supersede. The Boeing Company regards the information or procedures described herein as having a direct or indirect bearing on the safe operation of this model airplane.

INSTRUCTIONS: Complete the columns on the Bulletin Record for this bulletin at the time of filing in the Operations Manual. File this bulletin in numerical order following the Bulletin Record. This bulletin replaces Operations Manual Bulletin 75-7, dated August 10, 1975 and DL-5, dated October 24, 1975.

THE FOLLOWING PROCEDURE AND/OR INFORMATION IS EFFECTIVE UPON RECEIPT.

BACKGROUND INFORMATION: Recently one operator experienced a fracture of the leading edge slat retract lock ring on three actuators and a second operator experienced a similar fracture on one actuator. The fractured rings were discovered in actuators which had been removed from service due to alar operation, intermittent slat position light illumination and external leakage. These actuators had accumulated 3012 to 4638 flight hours prior to their removal from service.

Two operators have inspected a total of 89 actuators for possible fractured lock rings. None of these units were found to have fractured retract lock rings. Therefore, the existence of additional fractured retract lock rings on in-service units is believed to be remote. In addition, testing has indicated that a fractured retract ring is evident by the inability of the amber in-transit light to extinguish when the slats are extended or retracted, intermittent amber in-transit light illumination or alar slat operation. It is believed that these symptoms will occur for several slat actuations before locking capability is lost.

The leading edge slats are held in the retracted position by:

1. The retract lock ring.
2. Hydraulic System "A" pressure.
3. Air loads, except when speedbrakes are extended at Mach numbers above M.80.

727 Operations Manual Bulletin 75-7, dated March 10, 1976 (cont.)

Thus, a failure of hydraulic system "A", combined with a severely fractured or missing retract lock ring, followed by use of speed brakes above Mach .80 may cause one or more slats to extend and significant lateral control would be required to prevent high roll rates. The probability of this double failure and sequence of events is extremely remote, and to date this condition has not occurred in service.

The leading edge flap actuators do not incorporate a lock device, and if hydraulic system "A" failure occurs, they will be held in the retracted position by airloads.

RECOMMENDATION: Flight crews noting one or more of the following symptoms during leading edge slat operation on the ground or inflight should enter the observed indications in the airplane Technical Log for immediate maintenance action prior to the next flight:

1. Amber in-transit light fails to extinguish when slats are extended or retracted.
2. Intermittent amber in-transit light illumination.
3. Slow slat operation.

Leading edge slat malfunctions would initially be detected by observing the amber leading edge flap light on the forward panel. The flight engineer would then select POSITION TEST on the leading edge device (LED) annunciator panel and verify which leading edge flap or slat is not in agreement with selected flap position. With the trailing edge flaps retracted, any asymmetrical extension of a leading edge flap or slat would be evident by roll input. Illumination of a leading edge slat light on the flight engineer's panel without a roll input would confirm an LED indicating system malfunction or a possible lock ring failure.

TEMPORARY OPERATION INFORMATION: The following temporary operating procedures apply to all 727 airplanes equipped with either Decoto or Ronson leading edge slat actuators:

1. If any of the above symptoms occur during flap retraction following takeoff, consider return to airport of takeoff. If decision to continue flight is made with a slat amber in-transit light illuminated, do not exceed Mach .80.
2. If an amber slat in-transit light illuminates in cruising flight, reduce speed to Mach .80 or below.
3. If hydraulic system "A" pressure is lost in flight, do not use speed brakes at speeds above Mach .80.

OPERATIONS MANUAL INFORMATION: A formal revision to the Boeing Operations Manual is not planned, as the leading edge flap actuators will be modified to prevent lock ring failures. Appropriate information on correction action will be provided at a later date.

APPENDIX F
FLIGHT TEST DATA

FLIGHT TEST - FDR

AIRCRAFT CONFIGURATION --- TE FLAPS 2°
NOS. 2, 3, 6, and 7 LE SLATS EXTENDED ABOUT 333

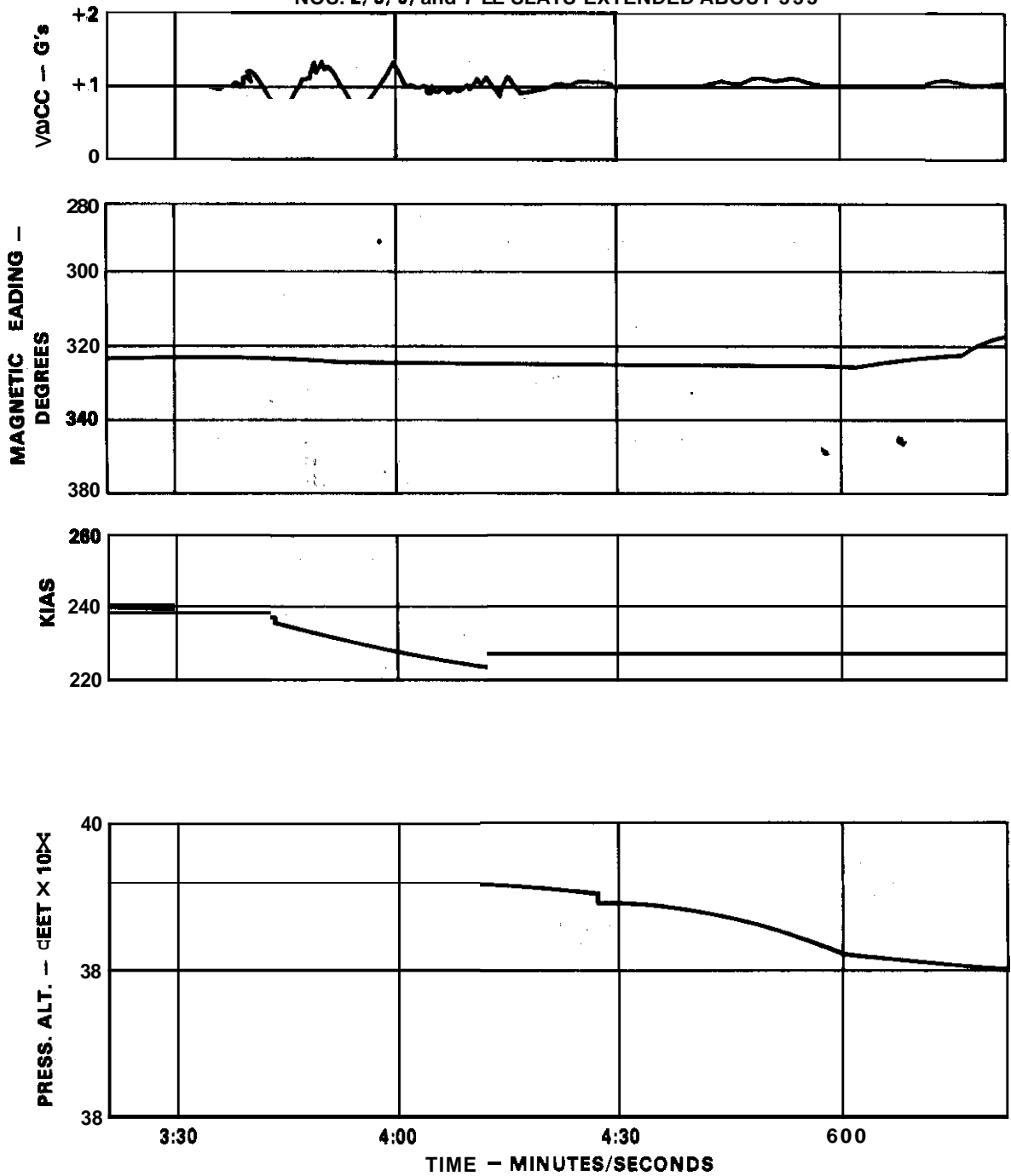

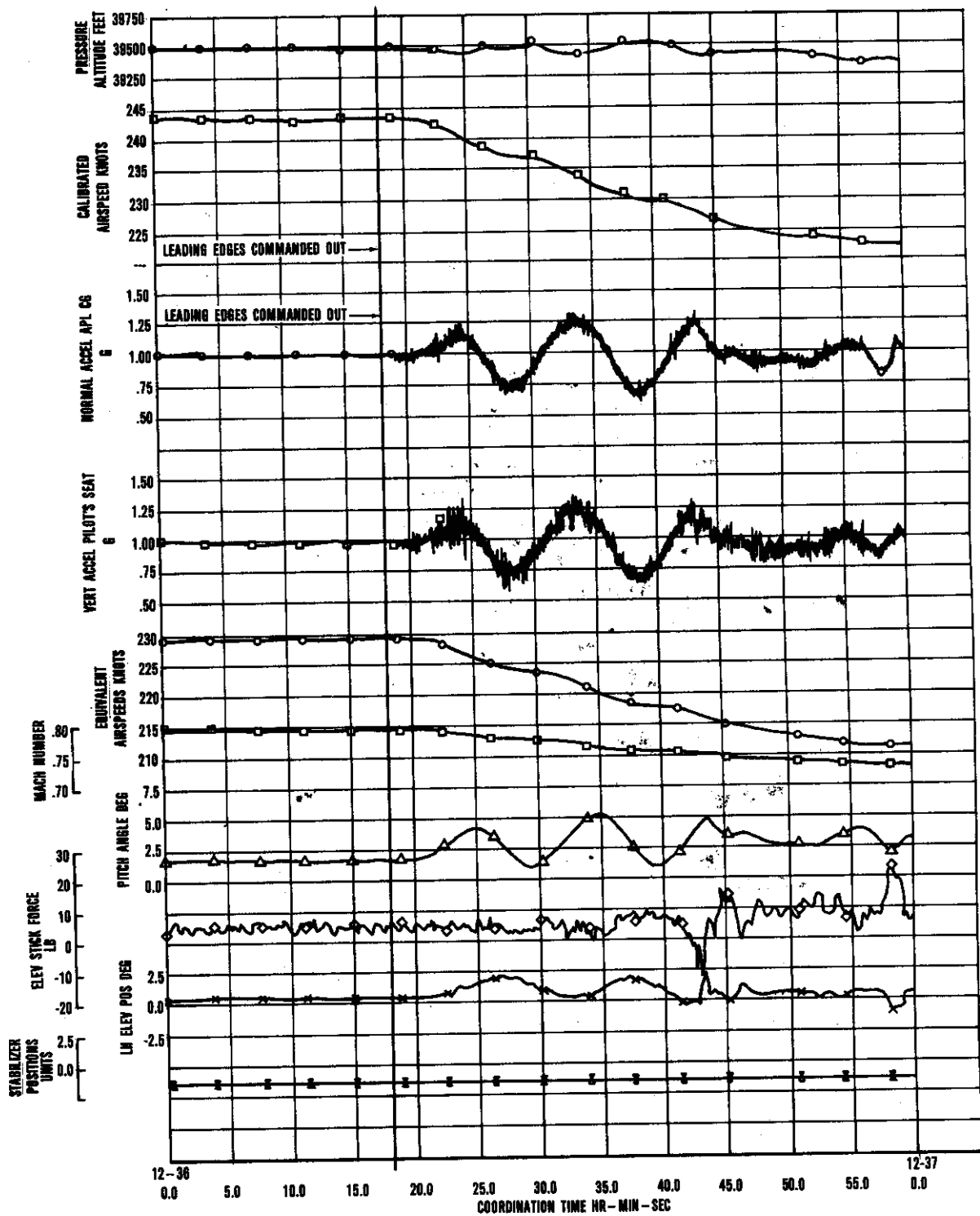

FLIGHT TEST RECORDINGS